

Mounting Instruction
SKiM®63/93
IGBT Modules

Revision:	1.7
Issue date:	2016-02-26
Prepared by:	Anastasia Schiller
Approved by:	Peter Beckedahl

Keyword: SKiM63/93, Mounting Instruction

Content

1. Preparation, Surface Specifications	1
2. Assembly	2
2.1 Application of Thermal Paste.....	2
2.2 Mounting the Pressure Part to the Heat Sink.....	2
2.2.1 Standard Mounting of the Pressure Part to the Heat Sink	3
2.2.2 Mounting of the Pressure Part to the Heat Sink using a Press.....	3
2.3 Case to Heat Sink Assembly	5
2.4 Mounting to the Main Terminals	6
2.5 Paralleling of AC Terminals	7
2.6 Mounting the Driver Printed Circuit Board.....	7
2.6.1 Standard Mounting of the Driver PCB.....	9
2.6.2 Mounting of the Driver PCB using a Press.....	10
3. Removing the SKiM from the Heat Sink	10
4. ESD Protection.....	10

1. Preparation, Surface Specifications

To obtain the maximum thermal conductivity, the underside of the module must be free of grease and particles. Further, the contact springs have to be clean and should never come into contact with hands to ensure a reliable electrical contact over the long-term.

The heat sink must fulfil the following specifications:

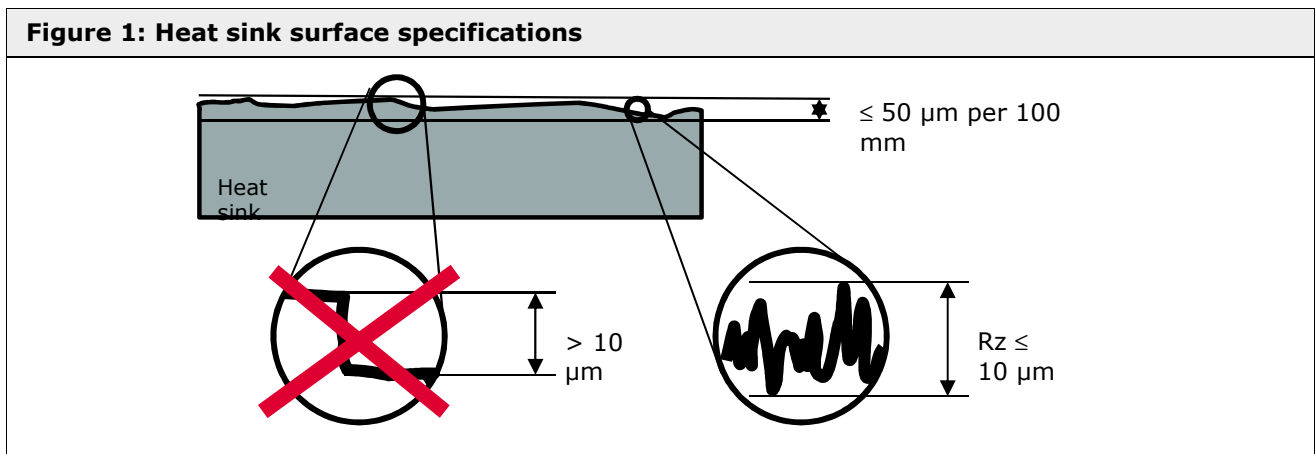

- Unevenness of heat sink mounting area must be $\leq 50\mu\text{m}$ per 100 mm (DIN EN ISO 1101)
- Roughness "Rz" $\leq 10\ \mu\text{m}$ (DIN EN ISO 4287)
- No steps $> 10\ \mu\text{m}$ (DIN EN ISO 4287)

Surface of heat sink should be free of grease, e.g. by cleaning the heat sink in a fat-dissolving solvent. A good indication is given by the DIN 53364, surface tension $\geq 32\ \text{mN/m}$. Tap holes must be free of turnings. The supplier of the heat sinks should choose adequate packaging to avoid contamination and mechanical damage during transport.

2. Assembly

Before setting up the electrical connection (including any electrical incoming test), the module must first be mounted onto the heat sink as described below. The mounting of the pressure part (see section 2.2) establishes the electrical connection for the main terminals. The mounting of the printed circuit board as described in section 2.6 provides a safe connection of the auxiliary springs.

2.1 Application of Thermal Paste

SKiM63/93 modules come with pre-applied silicone based thermal paste. There are two options: P12 WACKER CHEMIE or HpTp (a high performance thermal grease). A $21\mu\text{m} \pm 6\mu\text{m}$ thick paste layer is applied by a screen printing process, which is optimized for the SKiM63/93 modules.

2.2 Mounting the Pressure Part to the Heat Sink

Recommended

- gloves (e.g. Nylon with PU fingertips)
- bouffant caps

Before mounting, the heat sink surface must be cleaned. Well proven is the usage of a tissue (WYPALLx70 Kimberly-Clark) and Isopropanol.

Before mounting, remove the ESD-cover.

Please note: after removal of the ESD-cover, the SKiM module must not be turned up-side down until the PCB board is mounted (see section 2.6). Otherwise the auxiliary contact springs may drop out of the spring domes.

The SKiM module has to be placed onto the appropriate heat sink area from above. During the entire mounting process, the module must not be moved on the heat sink, not even for minor adjustments. For easy mounting SEMIKRON recommends a guidance tool in the assembly process (see Figure 2).

Figure 2: Example of guidance tool

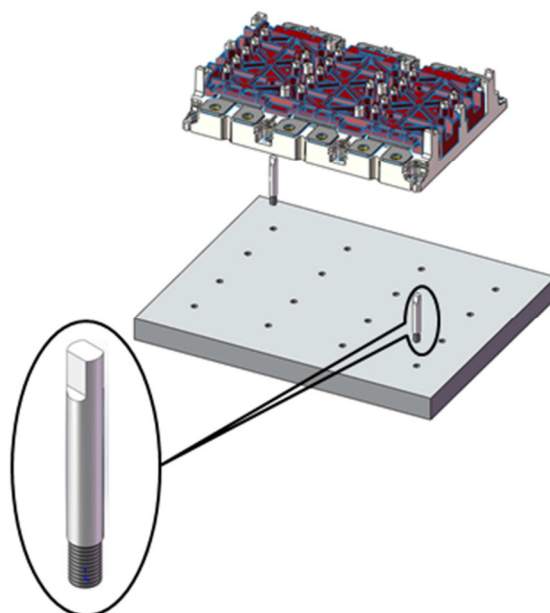

SEMIKRON recommends the following screw (according to DIN EN ISO 898-1)

- Inner hexagon screw or Inner torx head screw
- M4 - 8.8
- Strength of screw: "8.8"
= Tensile strength - $R_m = 800 \text{ N / mm}^2$
= Yield point - $R_e = 640 \text{ N / mm}^2$

To comply with the creepage and clearance distances for 1200 V, the height of the screw head must not exceed 4 mm. For the same reason washers are not allowed and not necessary.

Figure 3: Assembly order for screws for the pressure part of SKiM modules (assembly to heat sink)

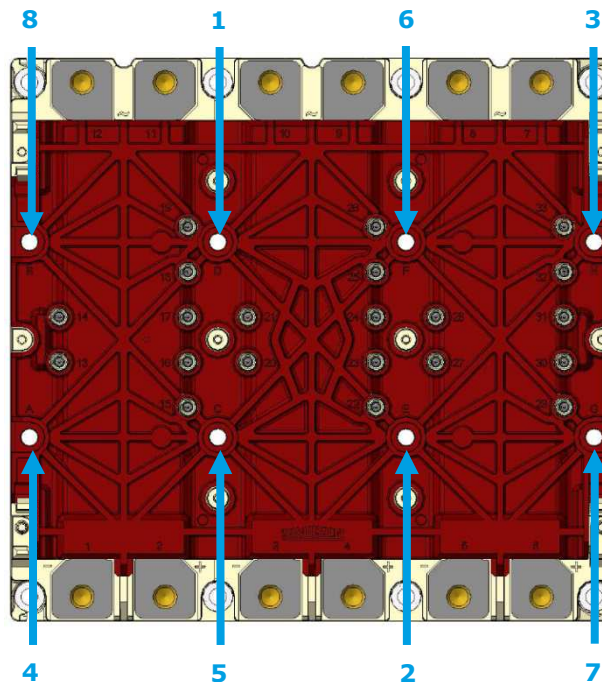

2.2.1 Standard Mounting of the Pressure Part to the Heat Sink

After the module has been positioned on the heat sink, the screws have to be pre-tightened. Then the mounting torque M_s has to be applied. Pre-tightening and final tightening has to be done in the order given in Figure 3. During the assembly process the thermal paste will spread evenly, to achieve reliable and homogeneous thermal contact.

Assembly steps:

- Step 1: Pre-Tightening screws 1-8 (see Figure 3) with $1,5\text{Nm} \pm 10\%$
- Step 2: Tightening screws 1-8 (see Figure 3) with $3,5\text{Nm} \pm 10\%$
- Step 3: Re-Tightening screws 1-8 (see Figure 3) with $3,5\text{Nm} \pm 10\%$

For the screwing process a maximum speed of 300rpm is recommended to ensure an even distribution of the thermal interface layer during the module mounting

2.2.2 Mounting of the Pressure Part to the Heat Sink using a Press

Instead of using a three-step mounting process as explained above a press can be used to hold down the pressure part. After positioning the module on the heat sink, the pressure part is pressed down with a defined force.

The press should apply following forces to the pressure part:

- For SKiM63 housings 2500 N \pm 5%
- For SKiM93 housings 4000 N \pm 5%

Figure 3 shows an example pressure part's bottom side, Figure 4 shows the positioning of the SKiM63/93 below the press and how the press applies the pressure exactly in the full area of the pressure part, between the spring contacts.

Figure 4: Example of pressure part's bottom side

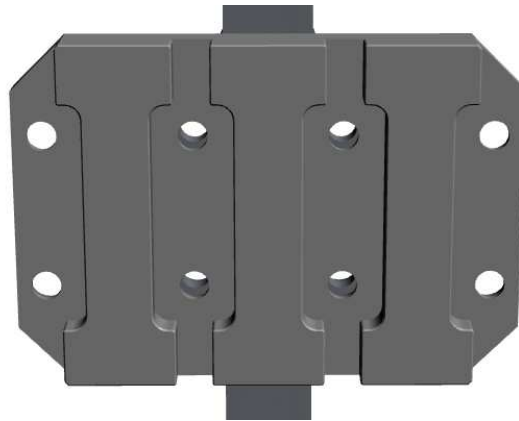
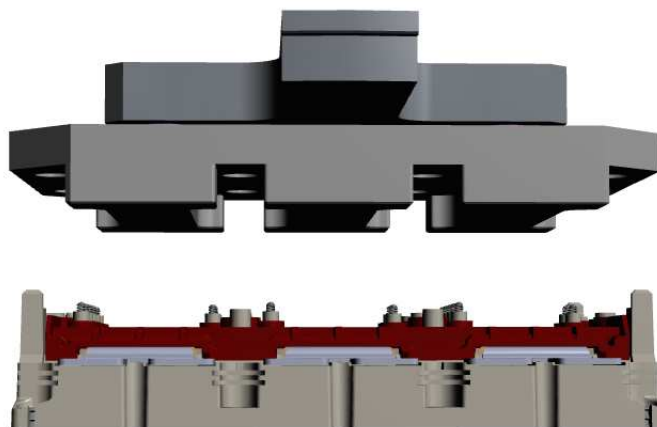

Figure 5: Positioning of press and SKiM63/93



In order to achieve an even distribution of the thermal paste on the DBC the press has to move down slowly. The minimum time of 3s is recommended from contact of the press with the module until the pressure part is fully pressed down.

With this procedure a pre-tightening is not required, the mounting can be done in one step with a recommended mounting torque of 3 Nm \pm 10%. Nevertheless the screw mounting order as shown in Figure 3 is recommended to be used.

Please note: The given torque values are recommended values and have to be validated by customer depending on the production equipment and application.

2.3 Case to Heat Sink Assembly

The second mounting step is to fix the outer module case on the heat sink. It is strongly recommended to mount these screws in any case, independent from the application.

Since the module itself is already mounted (see previous section), a single tightening step of screws 9-16 (see Figure 6) with $3,5\text{Nm} \pm 10\%$ is sufficient.

The screws for the case have to be assembled in the order described in Figure 1.

Figure 6: Assembly order for screws for the SKiM case (assembly to heat sink)

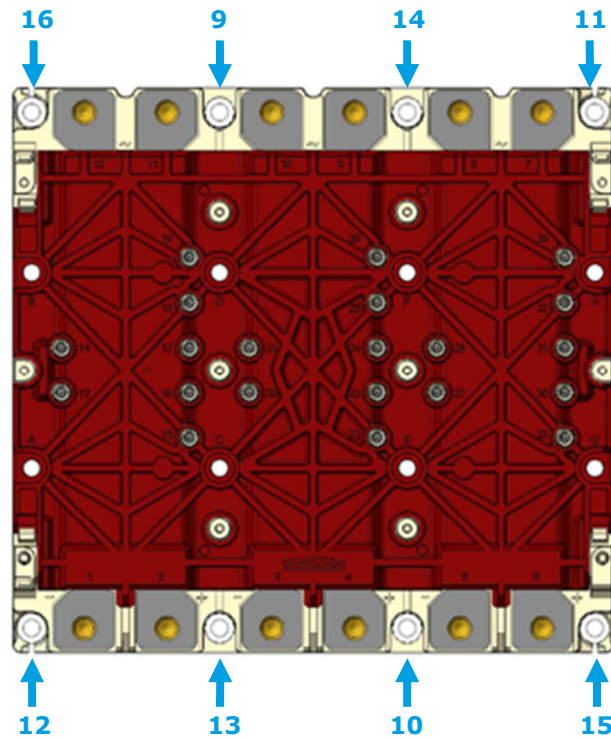

2.4 Mounting to the Main Terminals

SKiM is a power electronic module and is NOT MEANT to support the mechanical construction. The maximum forces applied to the main terminals must not exceed the values given in Figure 7. It is necessary to arrange additional mechanical supports if needed.

For the DC link connection it is better to apply a slight pressure force in $-Z$ direction than pull forces in $+Z$ direction. Nevertheless, the SKiM module is still not meant to support the DC link, therefore additional mechanical components have to be used. Mechanical support also has to be provided for the AC connection in order to protect the module from mechanical forces and unnecessary vibration stress.

Figure 7: Maximum forces at the main terminals

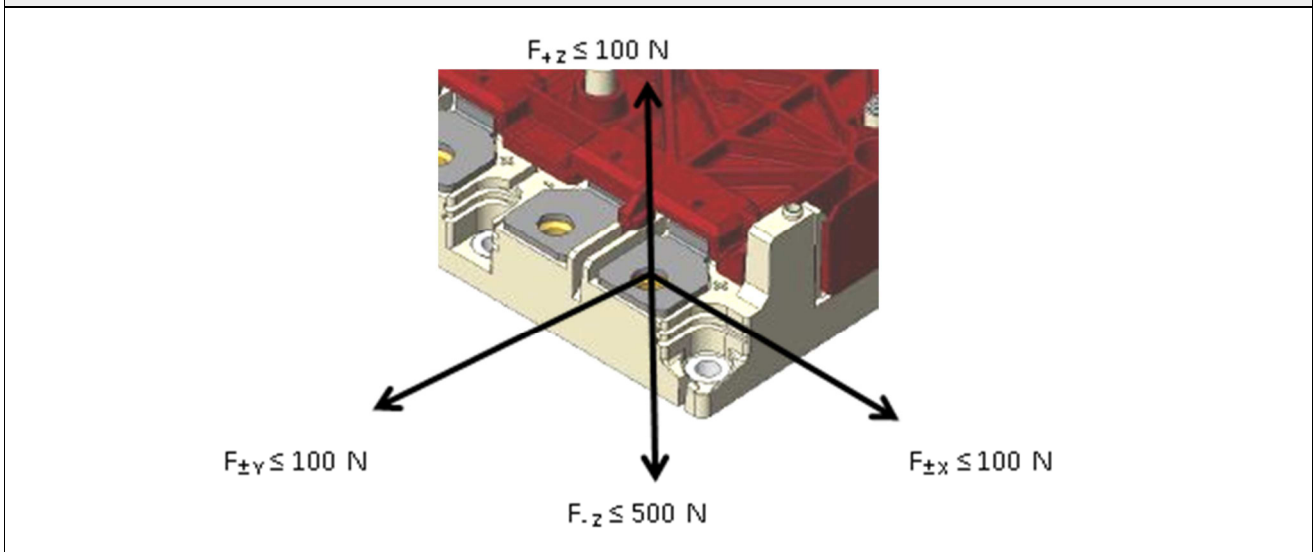

SEMIKRON recommends the following screw (according to DIN EN ISO 898-1)

- M6 - 8.8
- Strength of screw: "8.8"
 - = Tensile strength - $R_m = 800 \text{ N} / \text{mm}^2$
 - = Yield point - $R_e = 640 \text{ N} / \text{mm}^2$
- The depth of the screw in the module has to be between min. 6.0 mm and max. 8.5 mm.
- The mounting torque has to be between min. 6.0 Nm and max. 8.0 Nm

2.5 Paralleling of AC Terminals

Inside the SKiM module the two AC terminals are paralleled as shown in Figure 8. This means it is not necessary to connect both terminals. With just one screw the terminal can conduct the maximum terminal current $I_{t(RMS)}$ as given in the data sheets.

Figure 8: Detail: AC terminal of SKiM

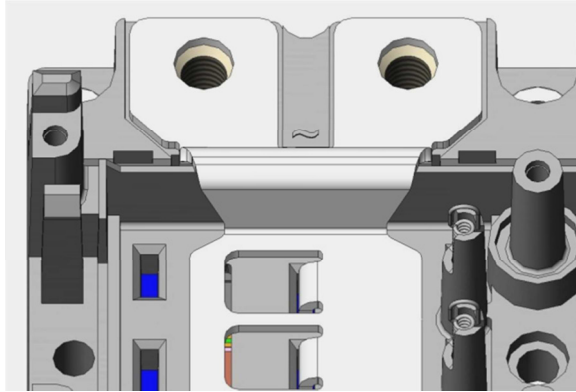

2.6 Mounting the Driver Printed Circuit Board

Figure 9: SKiM mounting domes and guiding pins

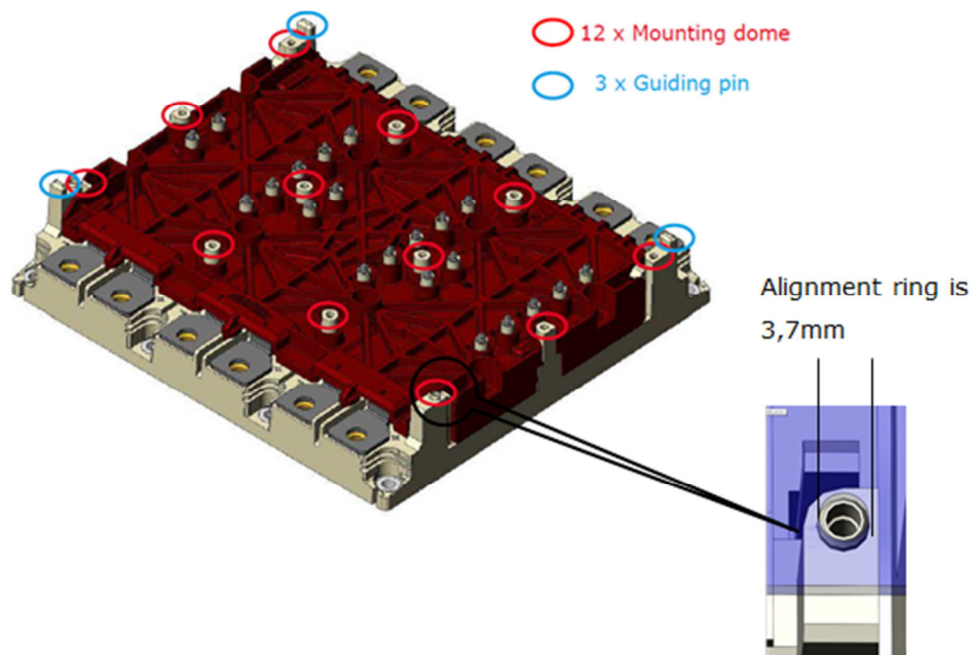

Before mounting the driver PCB the pressure part must be mounted correctly.
For all PCB mounting holes a drill diameter of 3mm is recommended except the 2 holes matching with alignment rings, which must be 3,8mm (see Figure 9).

SEMIKRON recommends the following screws for mounting the driver PCB:

- Self-tapping screws:
 - EJOT DELTA PT WN 5451 25x"L"
 - Screw head "TORX T8" or "Torx Plus"
 - Surface specification "A2K"
 - <http://www.ejot.de/>

SEMIKRON has tested the performance of these screws thoroughly. With screws different from recommended ones, the mounting domes might get damaged.

- The screw length "L" depends on the thickness "P" of the driver PCB and must ensure a screw-in depth of "Z" = 7mm ± 1mm.

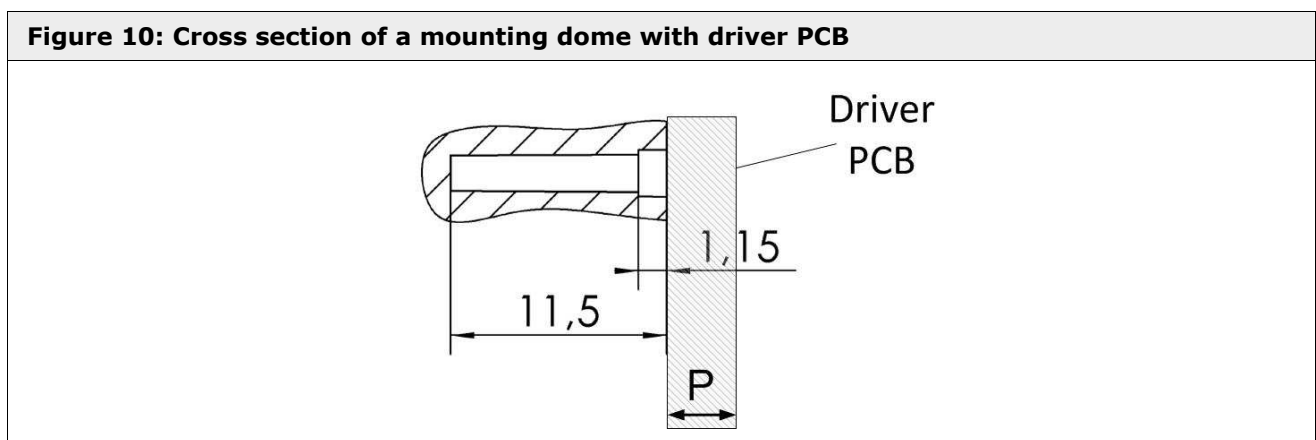

- The screw-in depth is defined as the length of the thread within the mounting dome. Figure 10 shows a cross section of a PCB mounting dome (SKiM63/93 datasheet drawing) including a driver PCB. In case of a driver PCB thickness of P = 1.8mm the required screw-in length is:

$$L = Z + 1.15\text{mm} + P = 7\text{mm} + 1.15\text{mm} + 1.8\text{mm} = \underline{9,95\text{mm}}$$

The nearest available screw length is 10mm (EJOT DELTA PT WN 5451 25x10).

- It is mandatory to use electric screw drivers. With pneumatic systems, the behavior of the clutch can lead to a shock and a torque overshoot which would damage the SKiM module.
- Any kind of manual mounting (e.g. with screw drivers or torque wrenches) can result in a damage of the mounting dome. The screwing process requires high revolving speeds as mentioned above.

2.6.1 Standard Mounting of the Driver PCB

- Standard mounting means that the driver PCB is placed on the module and the screwing process pulls the PCB towards the module until the board sits firmly on top of the mounting domes.

Please note: don't twist PCB when assembling it. For easy mounting the usage of alignment pins before assembling PCB at screw position 7 and 10 is recommended (see Figure 11).

Figure 11: Example of driver PCB alignment pins

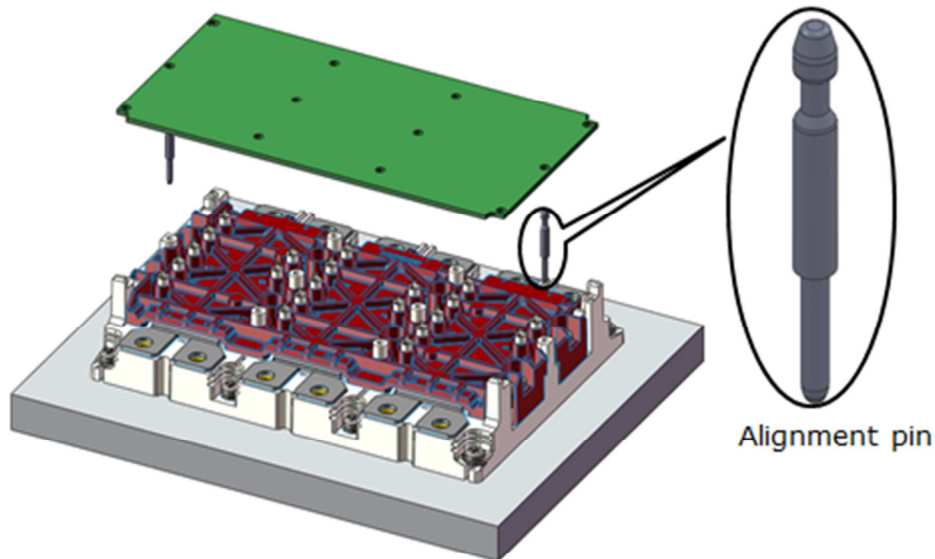

- It is mandatory to use electric screw drivers. Any kind of manual mounting can result in damage of the mounting dome. The automated screw driver should be programmed with following settings for torque and screwing speed:
 - Step 1: 400...600 rpm up to 0.4 Nm \pm 10%
 - Step 2: 30...50 rpm up to a maximum torque of 0.7 Nm \pm 10%
- Figure 12 shows the recommended fastening sequence for the driver PCB screws.

Please note: If the driver PCB has to be removed and remounted again for any reason the screws have to be placed accurately into the already existing thread by hand. After that the 2-step mounting procedure as mentioned above should be used. It must be avoided to cut a new thread as this can destroy the mounting dome.

Figure 12: Assembly order for the driver PCB screws

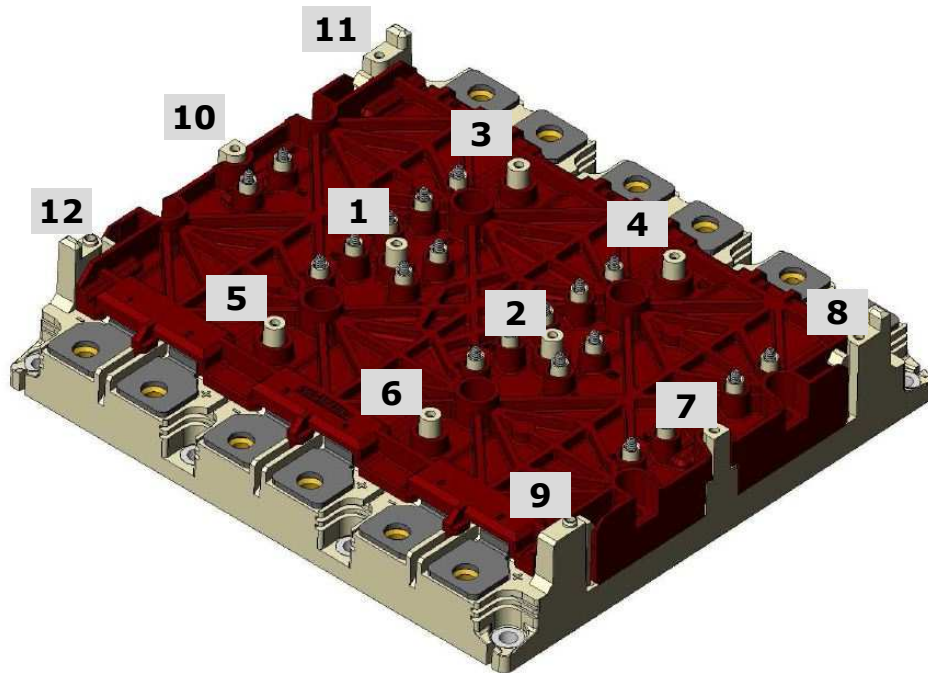

2.6.2 Mounting of the Driver PCB using a Press

- Alternatively to the standard mounting a press can be used that holds down the PCB to overcome the spring force of the auxiliary contact springs.
- In case the press is used the automated screw driver should be programmed with following settings for torque and screwing speed:
 - Step 1: 400...600 rpm up to 0.4 Nm \pm 10%
 - Step 2: 30...50 rpm up to a maximum torque of 0.5 Nm +10%
- The press should be constructed in a way that the force on top of the PCB is applied close to the springs. The applied force of the press should be 120N \pm 10%
- Please make sure that the press does not damage the driver PCB and its components when applied.

3. Removing the SKiM from the Heat Sink

The thermal paste provides good adhesion between the module and the heat sink. Since the DBC substrates with the chips are not glued to the case, the DBC substrates would stick to the heat sink when the module was removed as soon as the screws are loosened.

There are two recommended ways of removing the module:

- Wait 24 hours after the screws have been loosened and then slide the module carefully from the heat sink.
- Heat the heat sink to 60 °C after the screws have been loosened and then slide the module carefully from the heat sink.

4. ESD Protection

SKiM IGBT modules are sensitive to electrostatic discharge, because discharge of this kind can damage or destroy the sensitive MOS structure of the gate. For shipping, all SKiM modules are packed in conductive plastic trays that provide ESD protection.

When handling and assembling the modules it is recommended that a conductive grounded wristlet is worn and a conductive grounded workplace is used. All staff should be trained suitably for correct ESD handling.

Figure 1: Heat sink surface specifications.....	1
Figure 2: Example of guidance tool	2
Figure 3: Assembly order for screws for the pressure part of SKiM modules (assembly to heat sink)	3
Figure 4: Example of pressure part's bottom side	4
Figure 5: Positioning of press and SKiM63/93.....	4
Figure 6: Assembly order for screws for the SKiM case (assembly to heat sink)	5
Figure 7: Maximum forces at the main terminals	6
Figure 8: Detail: AC terminal of SKiM	7
Figure 9: SKiM mounting domes and guiding pins	7
Figure 10: Cross section of a mounting dome with driver PCB	8
Figure 11: Example of driver PCB alignment pins	9
Figure 12: Assembly order for the driver PCB screws.....	10

HISTORY

SEMIKRON reserves the right to make changes without further notice herein

DISCLAIMER

SEMIKRON reserves the right to make changes without further notice herein to improve reliability, function or design. Information furnished in this document is believed to be accurate and reliable. However, no representation or warranty is given and no liability is assumed with respect to the accuracy or use of such information, including without limitation, warranties of non-infringement of intellectual property rights of any third party. SEMIKRON does not assume any liability arising out of the application or use of any product or circuit described herein. Furthermore, this technical information may not be considered as an assurance of component characteristics. No warranty or guarantee expressed or implied is made regarding delivery, performance or suitability. This document supersedes and replaces all information previously supplied and may be superseded by updates without further notice.

SEMIKRON products are not authorized for use in life support appliances and systems without the express written approval by SEMIKRON.

SEMIKRON INTERNATIONAL GmbH
P.O. Box 820251 • 90253 Nuremberg • Germany
Tel: +49 911-65 59-234 • Fax: +49 911-65 59-262
sales.skd@semikron.com • www.semikron.com