

Technical Explanation SKiM4[®] MLI & TMLI

Revision:	1.5
Issue date:	2017-03-14
Prepared by:	Matteo Santoro
Approved by:	Werner Obermaier

Keyword: SKiM[®]4, MLI, TMLI, IGBT driver, performance, application

1. Introduction.....	2
1.1 Features	2
1.2 Customer advantages and benefits.....	3
2. Technical Details of SKiM [®] 4	3
2.1 Mechanical and electrical design.....	3
2.2 Electrical behaviour	6
2.2.1 Current distribution	6
2.2.2 Dynamic losses.....	11
2.3 Creepage and clearance distances	14
2.4 Isolation measurement	14
2.5 Chip technologies	15
2.6 Product portfolio and chipset	16
2.7 Type designation system	17
2.8 Chip positions	17
2.9 Thermal material data	20
3. Chip Technologies and Product Ranges.....	21
3.1 Trench IGBT	21
3.2 Inverse and Free-Wheeling diodes.....	22
3.3 Operating areas for IGBTs	22
3.3.1 Safe Operating Area (SOA).....	22
3.3.2 Reverse Bias Safe Operating Area (RBSOA).....	23
3.3.3 Short Circuit Safe Operating Area (SCSOA)	24
3.3.4 Selection guide	24
4. Temperature sensor and Isolation	24
4.1 Transient thermal impedance.....	25
5. Integrated Temperature Sensor Specifications	27
5.1 Electrical characteristics	27
5.2 Electrical isolation	28
6. Surface Specification.....	29
6.1 Heatsink	29
6.2 Mounting surface.....	30
7. Assembly	32
7.1 Application of thermal paste	32
7.2 Pre-applied thermal paste	32
7.3 Mounting the SKiM [®]	32
7.4 Dismounting the SKiM [®] from the heatsink	34
7.5 DC bus-bar mounting	34
7.6 Printed Circuit Board (PCB).....	36
7.6.1 PCB specifications	36
7.6.2 PCB assembly	37
8. Spring Contact System Specifications.....	40
8.1 Spring and contact specifications.....	40

8.2 PCB spring landing pad specifications.....	40
8.3 Storage conditions.....	41
9. Reliability	42
9.1 Standard tests for the qualification of SKiM®4&5 modules	42
9.2 Reliability of spring contacts	42
9.3 Lifetime calculation.....	44
10. Marking.....	46
10.1 Laser marking of modules	46
10.2 Laser marking for modules	46
11. Bill of Material.....	47
12. Packaging Specifications.....	48
12.1 ESD cover	48
12.2 Packaging boxes	49
12.3 Marks of packaging boxes	49
13. Environmental conditions	51
13.1 Climatic conditions, air humidity limits	51

1. Introduction

Today Solar and UPS applications demand modules with high power output, with reliable and compact design and with optimal thermal capabilities. These requirements are met and exceeded by the SKiM®4 power modules that use the SKiiP technology. SKiiP technology was first introduced by SEMIKRON in 1992 with aim of eliminating solder joints: the first pressure-contact IGBT power module with pressure-contact signal terminals and no base plate.

SKiM®4 offers in the same package the NPC and TNPC three level configurations

1.1 Features

Figure 1: SKiM®4 (footprint = 106,5 x 123mm²)

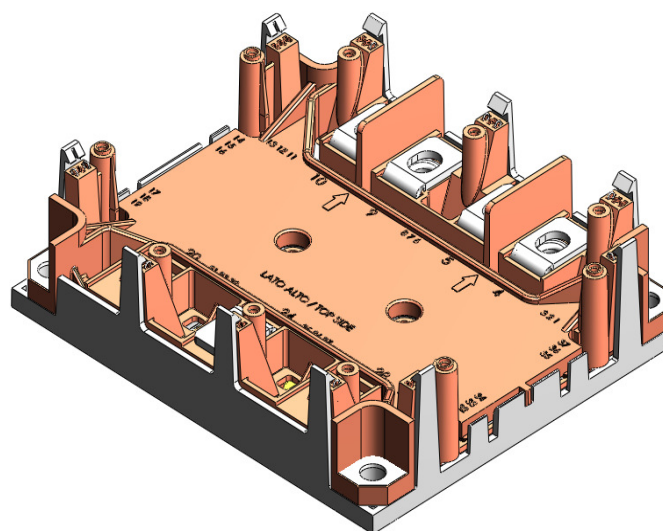
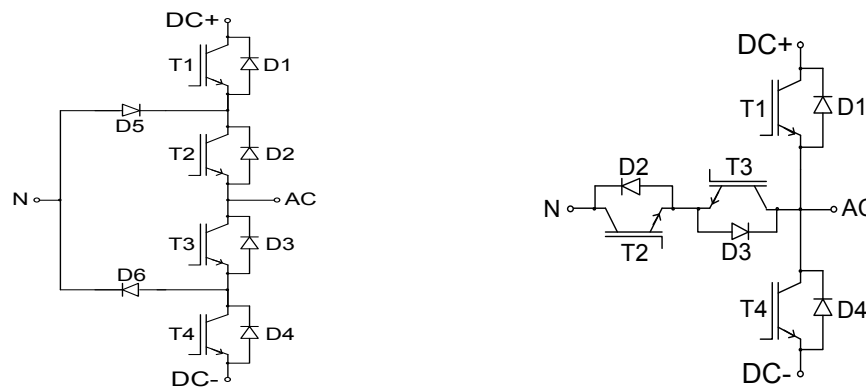

Figure 2: Electrical configuration of SKiM®4 MLI (left) and TMLI (right)



SKiM®4 modules feature a pressure-contact low-profile housing that boasts the following advantages:

- Baseplate-less design
- Spring contacts for auxiliary contacts
- Separate AC, DC terminals
- 17,5 mm main terminal height
- High insulation degree (2,5kV AC 1min / 3kV DC 1s)
- Complete product line covering a continuous current from 200A to 600A

1.2 Customer advantages and benefits

- Driver assembly;
 - Snap-in mounting with no additional wiring or connectors
 - Spring contacts do not require any additional soldering
- High reliability:
 - The reliability performance is confirmed by an extensive qualification program consisting of 17 different qualification and reliability tests performed for more than 10000h.
 - Reduce thermal stress due to the absence of baseplate
- Low stray inductances thanks to symmetrical internal layout
- Wide DBC area for better heatsink efficiency and, therefore, an effective cooling.
- UL recognized

Besides the aforementioned advantages the particular chipset configuration chosen for the NPC (MLI) and TNPC (TMLI) configurations helps the module to operate efficiently both as an inverter and as a rectifier.

2. Technical Details of SKiM®4

The SKiM®4 module is designed as a highly reliable module that meets the demands of most UPS, solar and drive applications in terms of shock and vibration stability, as well as high temperature capability and service life.

Conventional IGBT modules feature a construction where chips are soldered to a substrate and this substrate is soldered to a base plate. These layers are characterized by different coefficients of thermal expansion (CTE) and when exposed to active and passive temperature cycling induce thermal stress in the silicone, ceramic, copper and baseplate. The SKiiP technology avoids the use of the baseplate allowing a better match of materials and their CTEs and, as a consequence, reduces thermal stress and increases the reliability of the module.

The NPC and TNPC configuration in the different current ranges are available in the same mechanical package. TNPC and NPC configurations have the same power terminal layout but different signal spring contact layouts.

2.1 Mechanical and electrical design

SKiM®4 (Figure 3) is based on the well-established SKiiP technology. This means the Al₂O₃ DBC (direct bonded copper) substrate is pressed directly onto the heatsink without the use of a base plate.

Figure 3: Cross-sectional drawing of SKiM@4

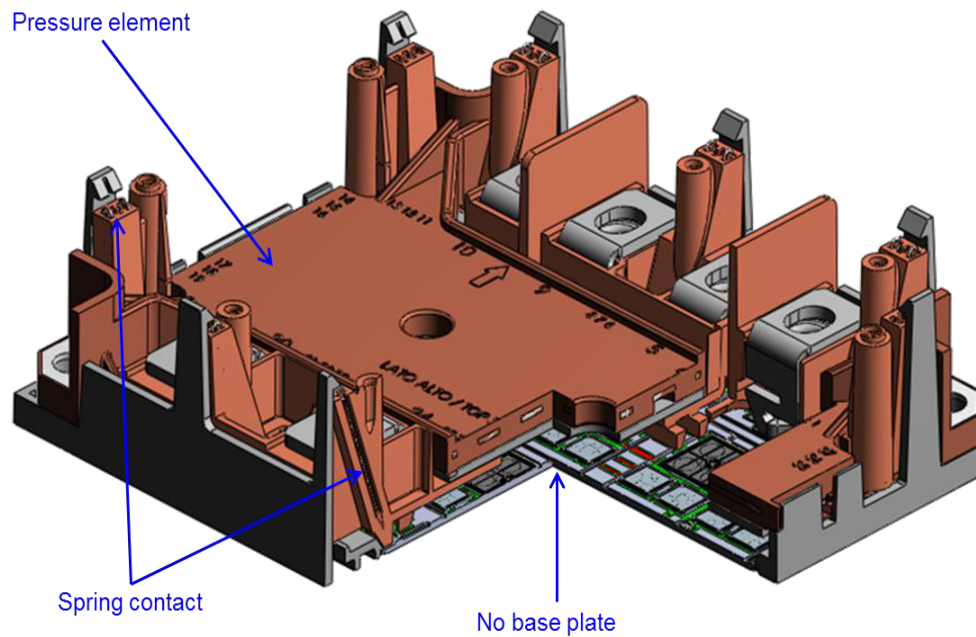

The construction principle of the SKiM@4 is quite simple:

- The silicon chips are soldered to the ceramic substrate
- Chips are bonded with wires
- Terminals are soldered to the ceramic substrate
- Frame and substrate are assembled and filled with silicone gel
- Finally bridge element, spring pads and pressure element are assembled to the substrate and frame

Once the pressure plate is mounted to the heatsink it induces pressure on the spring pad whose aim is to uniformly distribute the pressure on the below bridge element. The bridge element, thanks to different contact points, transfers the pressure on the substrate ensuring a perfect contact between the substrate area underneath the chips and the heatsink.

Figure 4: Construction principle of SKiM@4

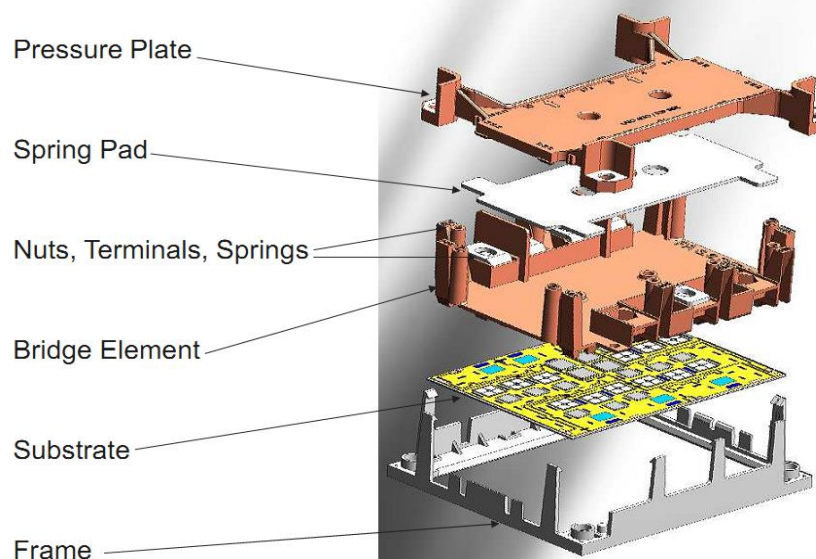

Figure 5: Bridge element with pressure points and substrate with contact points

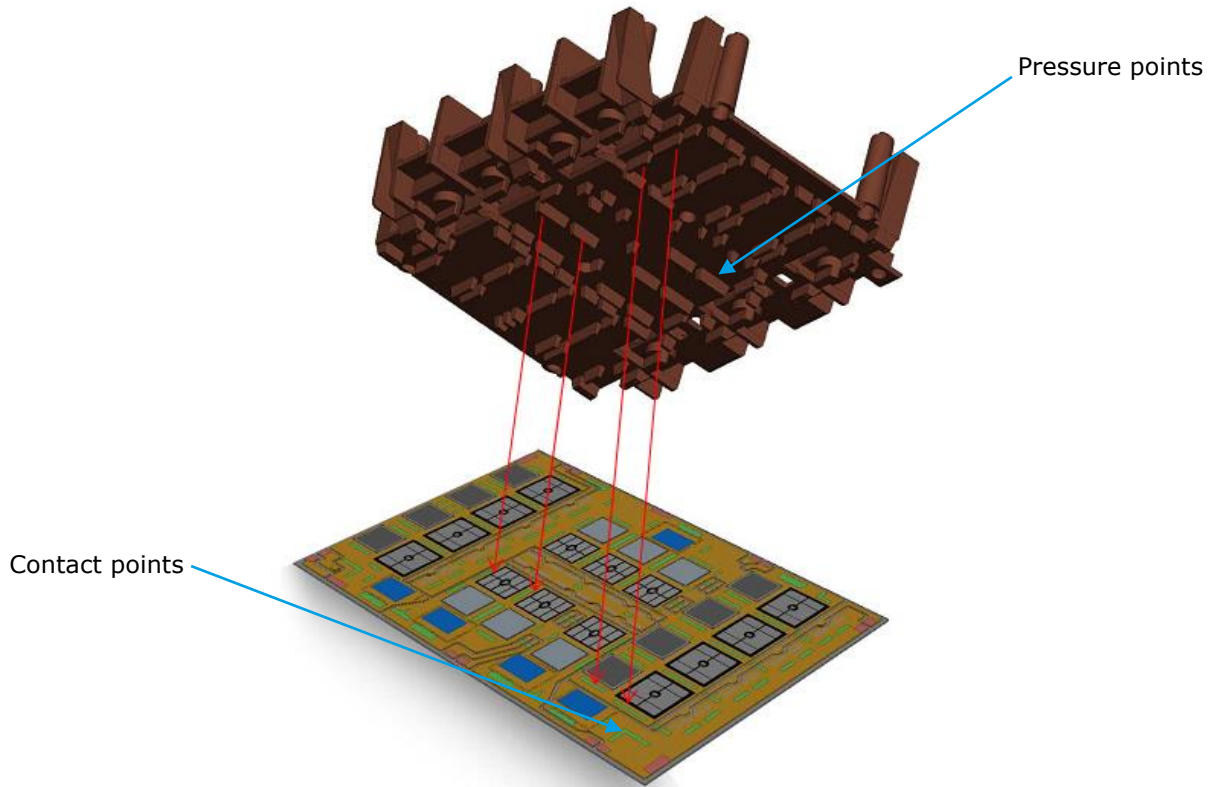
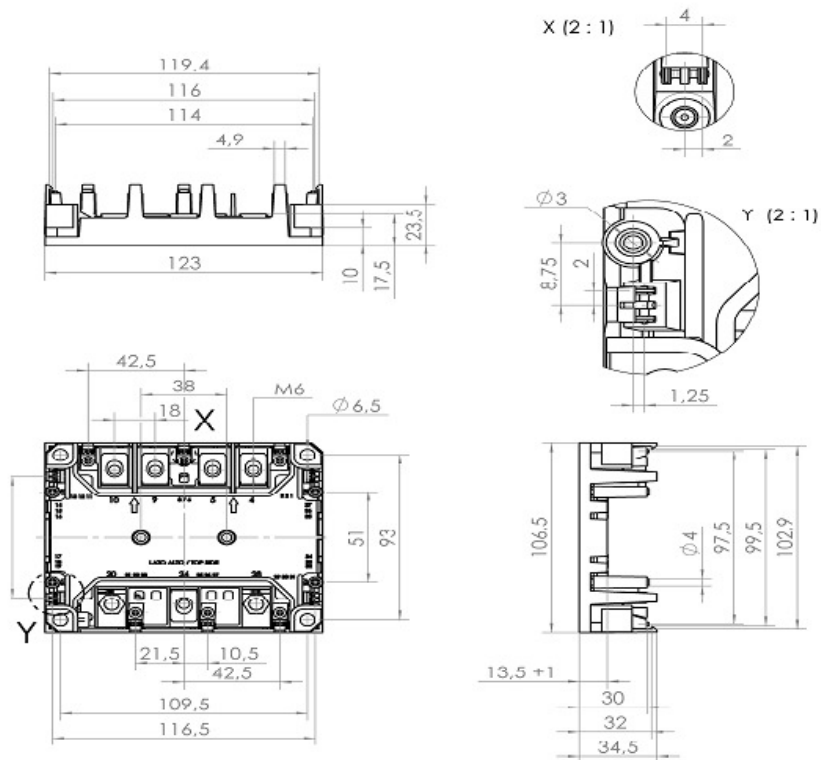

Figure 6: SKiM®4 mechanical layout



Contact springs are used for all of the auxiliary contacts (gate, auxiliary emitter and temperature sensor). These spring contacts allow for solder-free connection of the driver PCB.

2.2 Electrical behaviour

In a high-power module with paralleled chips, the switching behaviour and the resulting derating is important.

2.2.1 Current distribution

The current distribution between silicon chips is affected mainly by the parasitic stray inductances and the difference in these inductances between the chips. The main design feature that influences these parasitic stray inductances is the layout of the chips on the substrate and hence the commutation behaviour between switches.

If the DBC layout is not symmetric the commutation paths of the different currents have different parasitic inductances, leading to different currents, losses and, ultimately, temperatures in the different chips. To prevent individual chips from overheating, de-rating is necessary.

The SKiM®4 MLI and TMLI DBC layout is largely symmetric and has symmetric inductances in the current paths (Figure 7 and

Figure 9). The commutation behaviour across all chips is therefore very even and de-rating is not necessary.

Figure 7: SKiM®4 MLI conduction paths for positive (left) and negative (right) output current

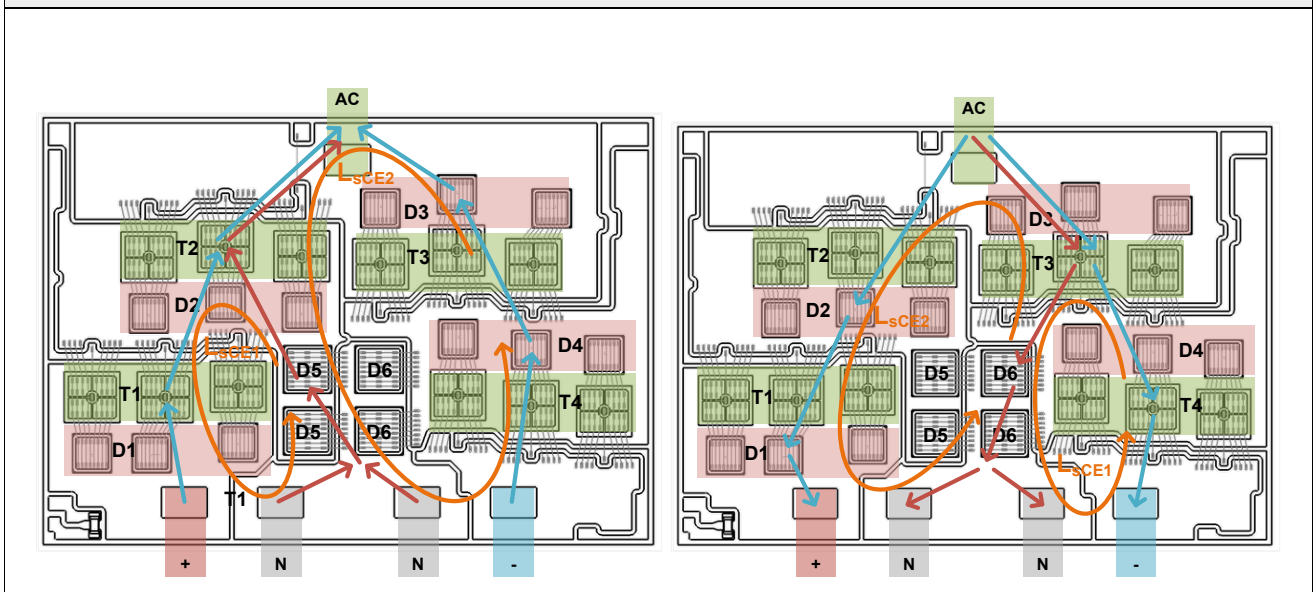

Figure 8: MLI commutation loops and inductances test set up

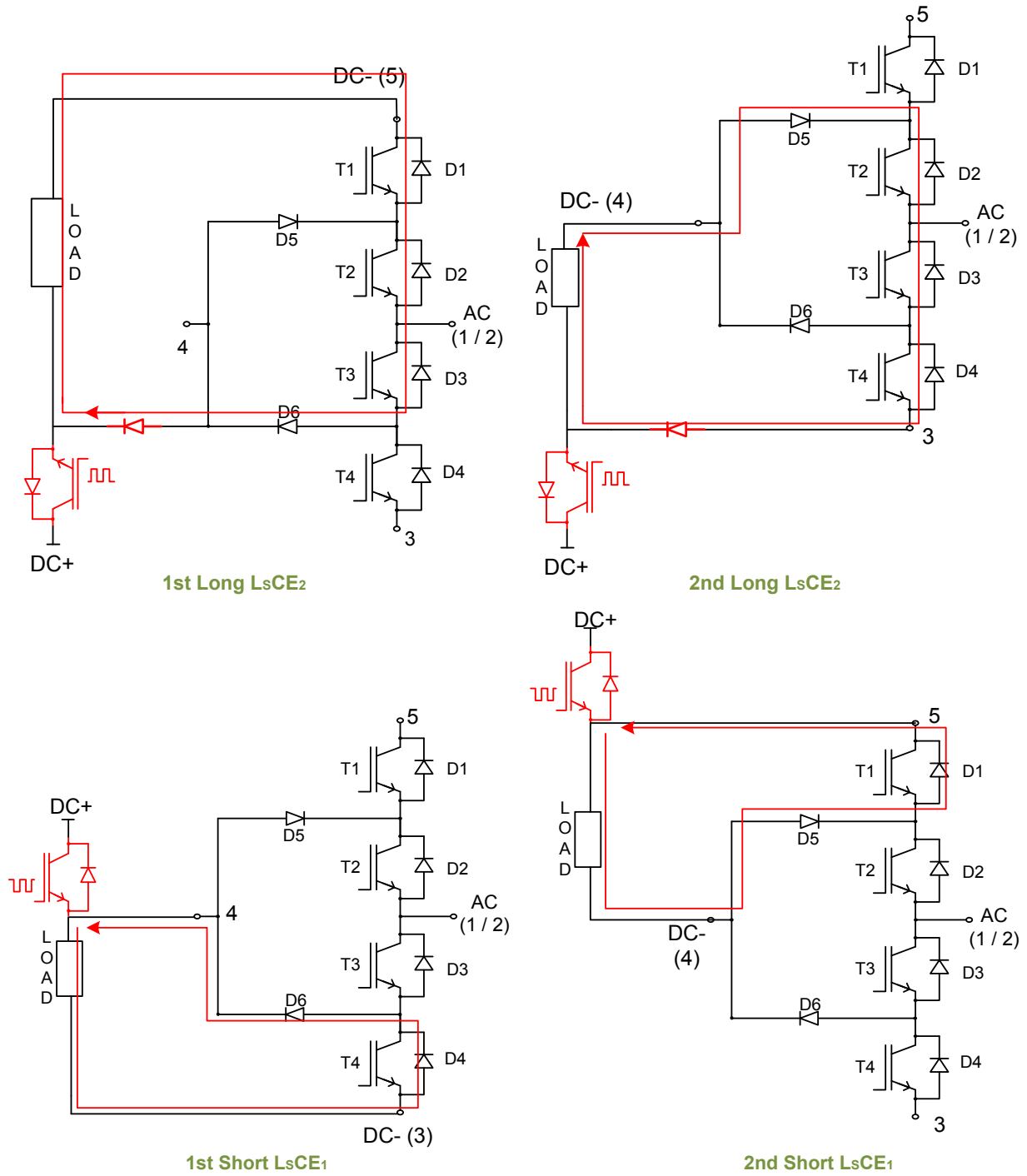

Figure 9: SKiM®4 TMLI conduction paths for positive (left) and negative (right) output current

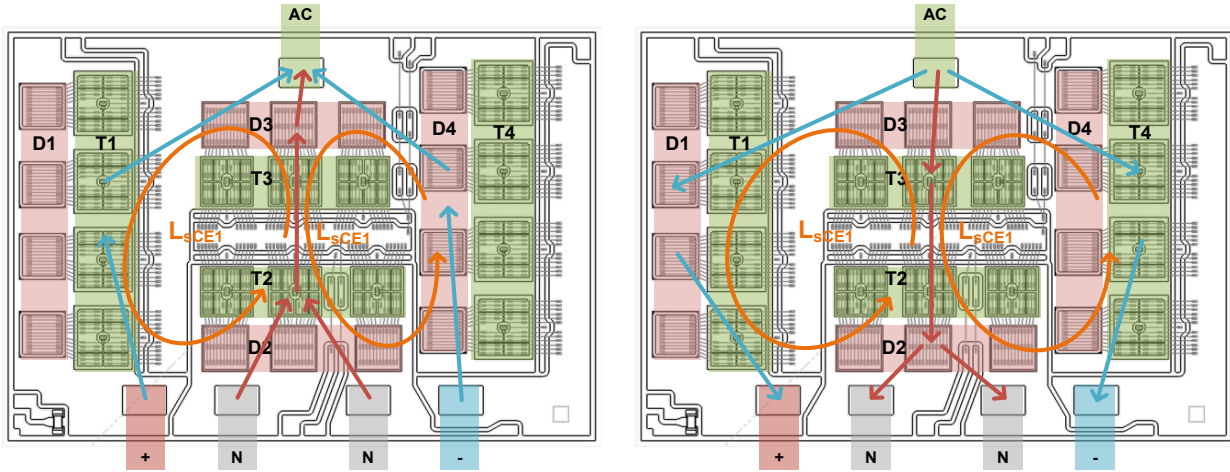
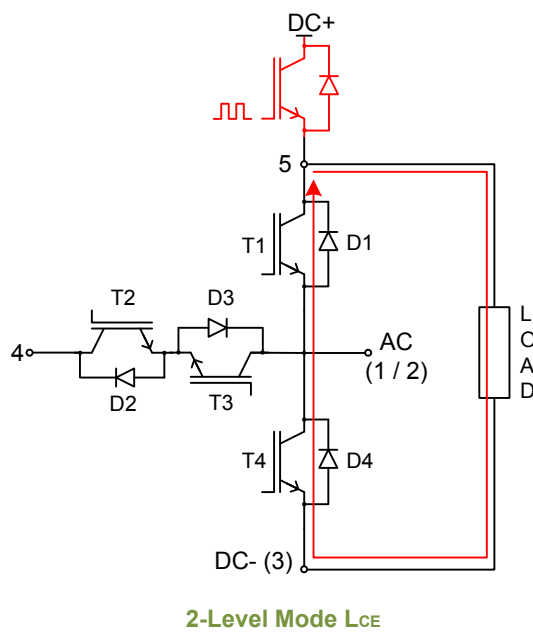
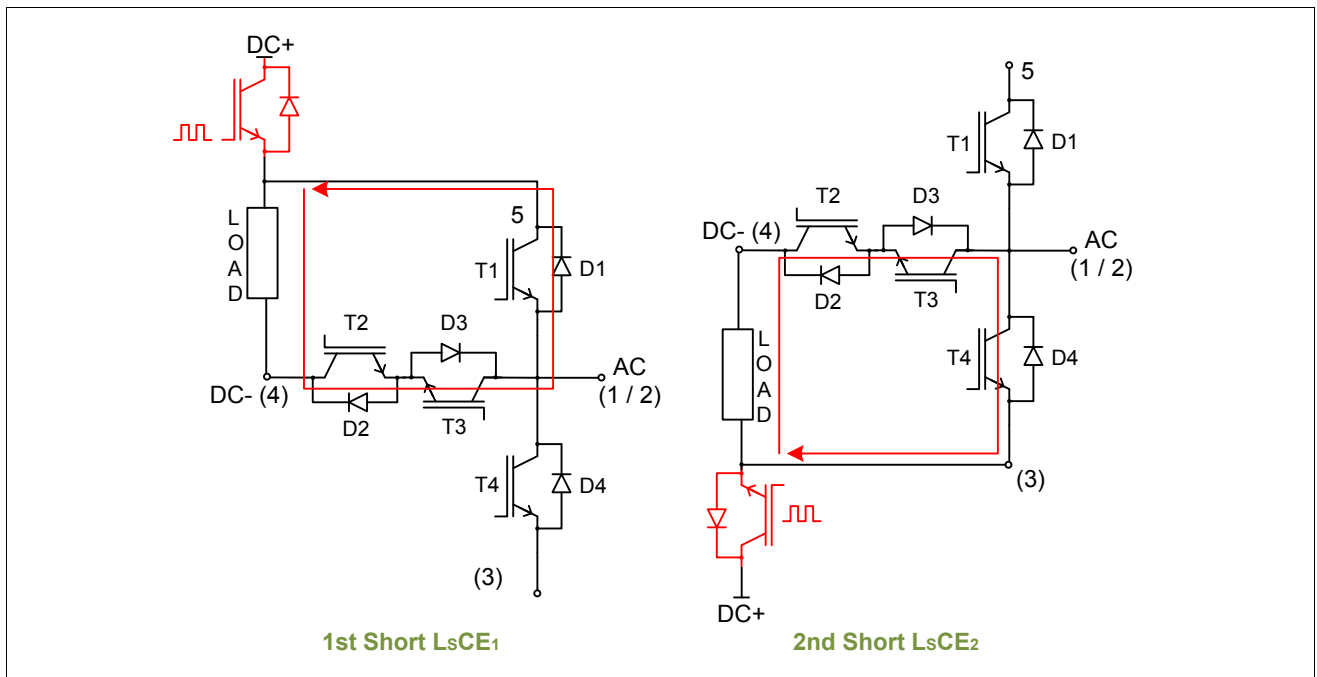

Figure 10: SKiM®4 TMLI commutation loops and inductances test set up





The commutation inductances are split in three different values:

- L_{CE} This is the commutation inductance in case a TNPC module is operated as 2-level device (test set up for the measure is shown in Figure 10).
- L_{sCE1} This is the commutation inductance of the 3-level commutation in TNPC and the short commutation in NPC (test set up for the measure is shown in Figure 8 and Figure 10). Higher measured value is chosen for the datasheet value.
- L_{sCE2} This is the commutation inductance of the long commutation in NPC; it does not exist in TNPC (test set up for the measure is shown see Figure 8): Higher measured value is chosen for the datasheet value. In Table 1 datasheet values for some SKiM@4&5 modules measured are shown

Table 1: Commutation inductances of SKiM®4&5 TMLI / MLI		
	SKiM® 601 TMLI 12E4B	SKiM® 301 MLI 12E4
L_{CE}	40nH	-
L_{sCE1}	29nH	22nH
L_{sCE2}	-	38nH
	SKiM® 401 TMLI 12E4B	SKiM® 201 MLI 12E4
L_{CE}	TBD	-
L_{sCE1}	TBD	TBD
L_{sCE2}	-	TBD
	SKiM® 301 TMLI 12E4B	
L_{CE}	TBD	
L_{sCE1}	TBD	
L_{sCE2}	-	

2.2.2 Dynamic losses

In 2014 SEMIKRON released new test measure set up to harmonize TMLI turn-on / turn off energy diagrams.

For further details it is recommended to refer to [6].

Based on this harmonization the following set up is defined

TNPC: Turn-on / Turn-off energy

1. *IGBT1* indicates without distinction T1 or T4 and *Diode2* indicates without distinction D2 or D3
2. *IGBT2* indicates without distinction T2 or T3 and *Diode1* indicates without distinction D1 or D4

In the TNPC datasheet dynamic losses related to IGBT1 refers to the turn-on / turn-off condition reported in Figure 11 and dynamic losses related to IGBT2 refers to the turn-on / turn-off condition reported in Figure 12.

Figure 11: TNPC: IGBT1 & Diode2 turn-on / -off energy

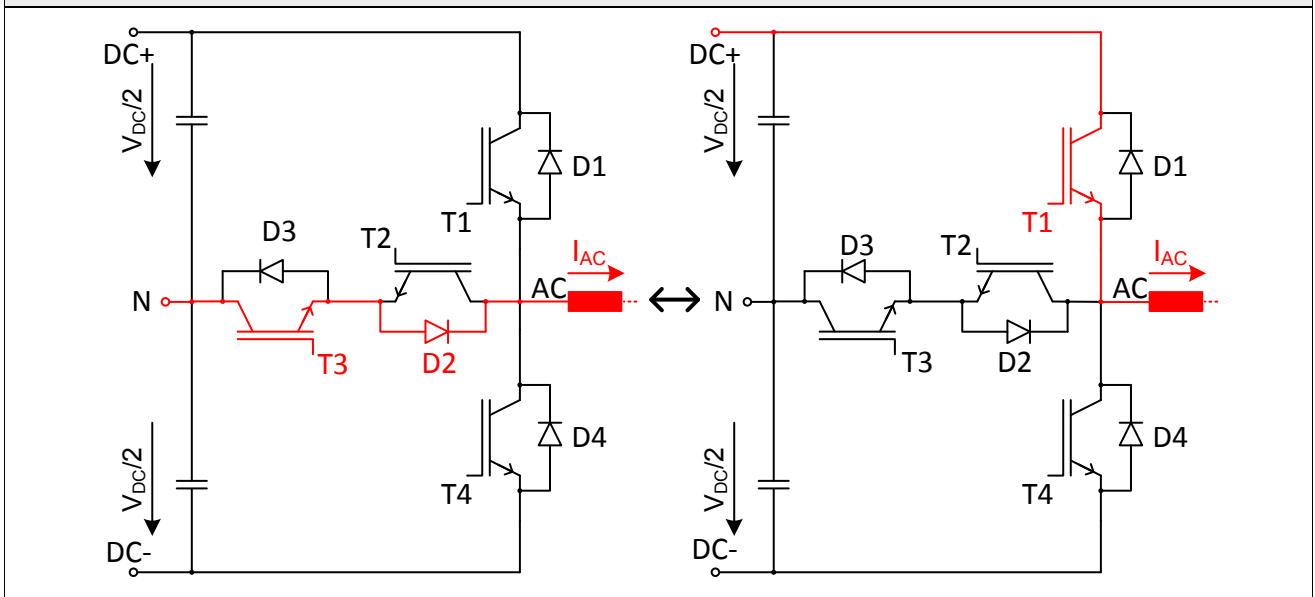
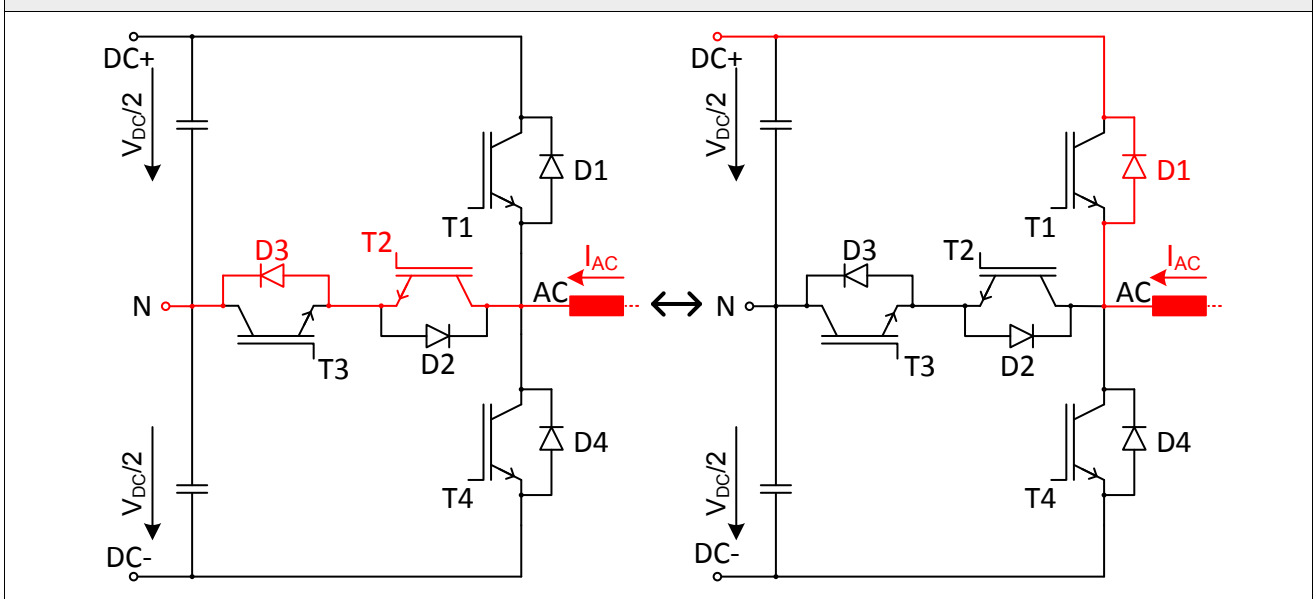

Figure 12: TNPC: IGBT2 & Diode1 turn-on / -off energy



NPC: turn-on / -off energy

In the NPC datasheets *IGBT1* indicates without distinction T1 or T4 and *Diode5* indicates without distinction D5 or D6 (Figure 13) and *IGBT2* indicates without distinction T2 or T3 and *Diode1* indicates without distinction D1 or D4 (Figure 13).

Figure 13: NPC: IGBT1 & Diode5 turn-on / -off energy

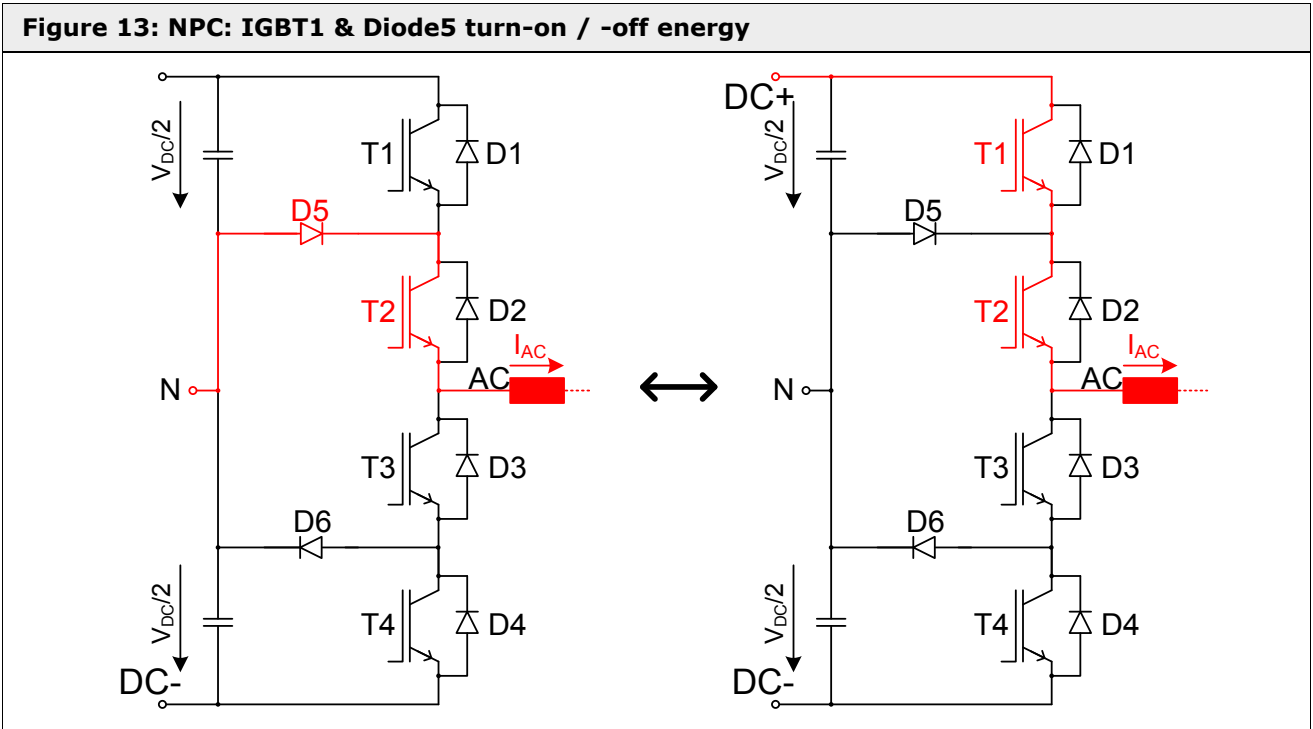
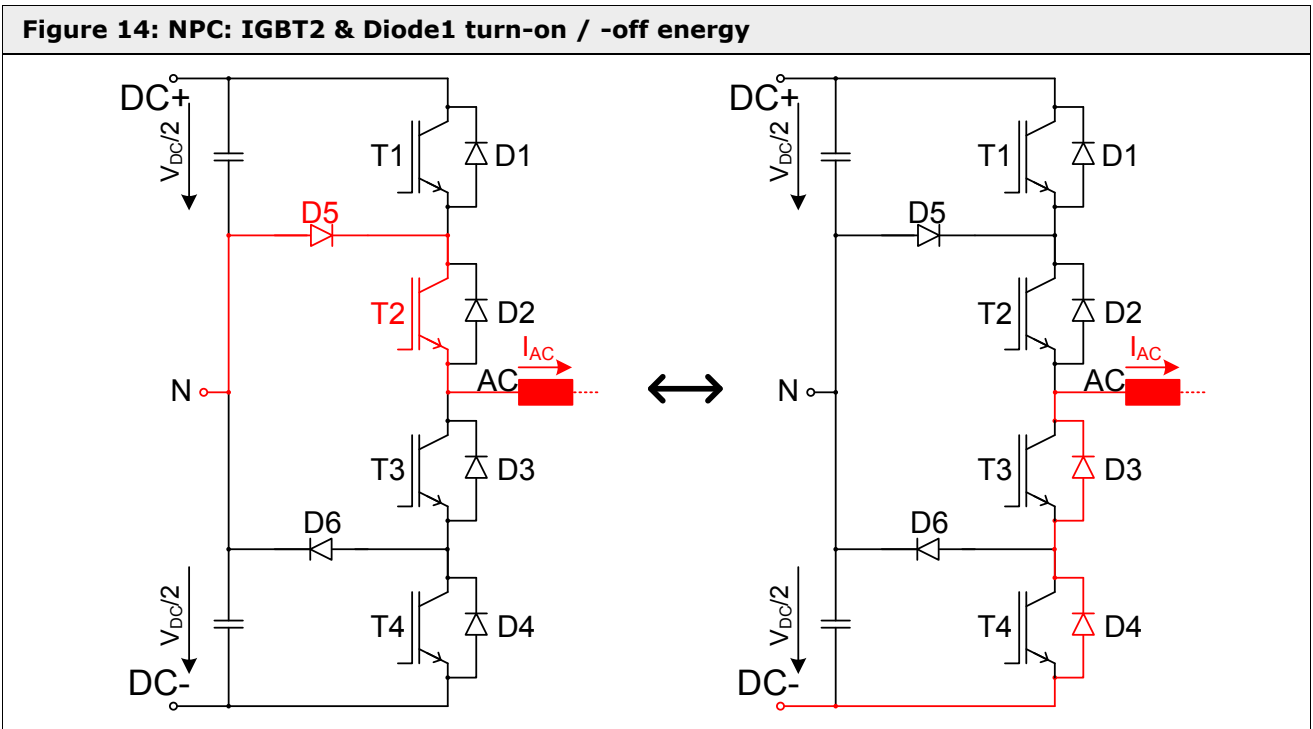

Figure 14: NPC: IGBT2 & Diode1 turn-on / -off energy



2.3 Creepage and clearance distances

All SKiM® IGBT modules comply with the following creepage and clearance distances:

- Grid voltage (line to line) = 1000Vrms
(for grounded delta configuration up to 2000m or TN grids up to 4000m)
- Maximum DC link voltage = 1500V
- Basic isolation
- Pollution degree 2
- Comparative Tracking Index "CTI" value
 - For the bridge (or pressure) element: > 400
 - For the white housing : = 175
 - For the pressure plate: = 600

Table 2: Creepage and clearance distances for SKiM®	
Creepage distance from main terminal to main terminal	≥ 14.6mm
Clearance distance from main terminal to main terminal	≥ 8.1mm
Creepage distance from any terminal to heatsink potential	≥ 21.0mm
Clearance distance from any terminal to heatsink potential	≥ 21.0mm

"From terminal to terminal" means for main and auxiliary terminals between high-voltage potentials, not between terminals with small differences in voltage potential, e.g. gate and emitter contacts ($\pm 20V$) or between the contacts of the temperature sensor.

The following sketches (Figure 15) show the distances:

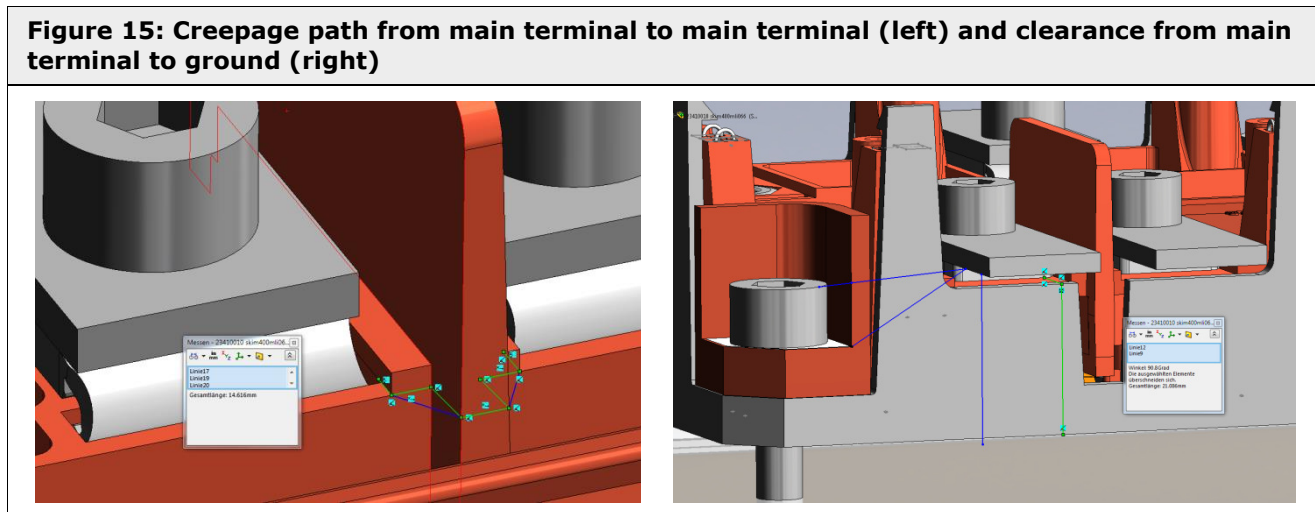

Inside the housing the DBC substrate is coated with a silicone gel for electric isolation. The gel has an isolation capability greater than 20kV/mm.

2.4 Isolation measurement

The specified isolation voltage is given in the data sheets. In the course of production, this isolation voltage is verified with a 100% test according to the DIN EN 50178 standard (VDE 0160).

The isolation measurement is performed short circuiting all main and auxiliary terminals (including main, auxiliary emitter, gate and temperature sensor contacts) and measured versus the base plate.

2.5 Chip technologies

SKiM®4 MLI and TMLI use mainly three types of IGBTs:

- 1700V IGBT4 Trench & Field Stop technology
- 1200V IGBT4 Trench & Field Stop technology
- 650V IGBT4 Trench & Field Stop technology

2.6 Product portfolio and chipset

Table 3: SKiM®4 MLI product portfolio and chipset

Name	Chip Description	Chip Name	Chip current [A]	Chip voltage [V]	Chips per Switch	Chips/Module
SKiM301MLI12E4	IGBT	IGC 99T 120 T6RM	100	1200	3	12
	APD	SKCD 53 C 120 I4F	100	1200	3	12
	CLAMP	SKCD 81 C 120 I4F	150	1200	2	4
SKiM201MLI12E4	IGBT	IGC 99T 120 T6RM	100	1200	2	8
	APD	SKCD 53 C 120 I4F	100	1200	2	8
	CLAMP	SKCD 53 C 120 I4F	100	1200	2	4
Name	Chip Description	Chip Name	Chip current [A]	Chip voltage [V]	Chips per Switch	Chips/Module
SKiM601MLI07E4	IGBT	IGC 100 T 65 T8 RM	200	650	3	12
	APD	SKCD 61 C 065 I4F	150	650	3	12
	CLAMP	SKCD 81 C 065 I4F	200	650	2	4
SKiM401MLI07E4	IGBT	IGC 100 T 65 T8 RM	200	650	2	8
	APD	SKCD 61 C 065 I4F	150	650	2	8
	CLAMP	SKCD 61 C 065 I4F	150	650	2	4
SKiM301MLI07E4	IGBT	IGC 76T 65 T8 RM	150	650	2	8
	APD	SKCD 42 C 065 I4F	100	650	2	8
	CLAMP	SKCD 42 C 065 I4F	100	650	2	4
SKiM201MLI07E4	IGBT	IGC 54T 65 T8 RM	100	650	2	8
	APD	SKCD 24 C 065 I4F	50	650	2	8
	CLAMP	SKCD 24 C 065 I4F	50	650	2	4

Table 4: SKiM®4 TMLI product portfolio and chipset

Name	Chip Description	Chip Name	Chip current [A]	Chip voltage [V]	Chips per Switch	Chips/Module
SKiM601TMLI12E4B	IGBT 1/4	IGC 142 T 120 T6RM	150	1200	4	8
	Diode 1/4	SKCD 81 C 120 I4F	150	1200	4	8
	IGBT 2/3	IGC 100 T 65 T8 RM	200	650	3	6
	Diode 2/3	SKCD 81 C065 I4F	200	650	3	6
SKiM401TMLI12E4B	IGBT 1/4	IGC 99 T 120 T6RM	100	1200	4	8
	Diode 1/4	SKCD 53 C 120 I4F	100	1200	4	8
	IGBT 2/3	IGC 100 T65 T8 RM	200	650	2	4
	Diode 2/3	SKCD 81 C065 I4F	200	650	2	4
SKiM301TMLI12E4B	IGBT 1/4	IGC 99 T 120 T6RM	100	1200	3	6
	Diode 1/4	SKCD 53 C 120 I4F	100	1200	3	6
	IGBT 2/3	IGC 76 T 65 T8 RM	150	650	2	4
	Diode 2/3	SKCD 61 C065 I4F	150	650	2	4
SKiM301TMLI12E4C	IGBT 1/4	IGC 99 T 120 T6RM	100	1200	3	6
	Diode 1/4	SKCD 53 C 120 I4F	100	1200	3	6
	IGBT 2/3	IGC 99 T 120 T6RM	100	1200	3	6
	Diode 2/3	SKCD 53 C 120 I4F	100	1200	3	6
SKiM301TMLI17E4C	IGBT 1/4	IGC 114 T 170 S8 RM	100	1700	3	6
	Diode 1/4	SKCD 56 C 170 I4F	100	1700	3	6
	IGBT 2/3	IGC 99 T 120 T6RM	100	1200	3	6
	Diode 2/3	SKCD 53 C 120 I4F	100	1200	3	6

2.7 Type designation system

SKiM® 601 TMLI 12 E4 B
 ① ② ③ ④ ⑤ ⑥

1. SKiM®: SEMIKRON integrated module
2. 601: 600A nominal current, 1: soldered chips
3. TMLI: electrical configuration (MLI or TMLI)
4. Collector-emitter voltage class of IGBT1 and Diode1 (TMLI) or all switches (MLI):
 06: 600V IGBT3 trench & field stop
 07: 650V IGBT4 trench & field stop
 12: 1200V IGBT4 trench & field stop
 17: 1700V IGBT4 trench & field stop
5. Chip generation of IGBT1 and Diode1 (TMLI) or all switches (MLI):
 E4: IGBT4 Infineon
6. Collector-emitter voltage class of IGBT2 and Diode2 (TMLI), no value (MLI):
 A: 600V IGBT3 trench & field stop
 B: 650V IGBT4 trench & field stop
 C: 1200V IGBT4 trench & field stop
 D: 1700V IGBT4 trench & field stop

2.8 Chip positions

For detailed temperature measurements the exact positions of the chips need to be known. Figure 16 and Figure 17 explain the coordinate system and orientation of the DBCs with the highest current ratings (fully equipped with semiconductor chips) belonging to one of the following families:

- SKiM® MLI – Figure 16
- SKiM® TMLI – Figure 17

The dimensions of the chip positions are given in Table 5 and Table 6.

Other modules in the product portfolio that belong to one of the aforementioned families feature chips that may be bigger in size or number compared to the lowest current rated module of the same family.

Figure 16: SKiM®4 MLI chip positions

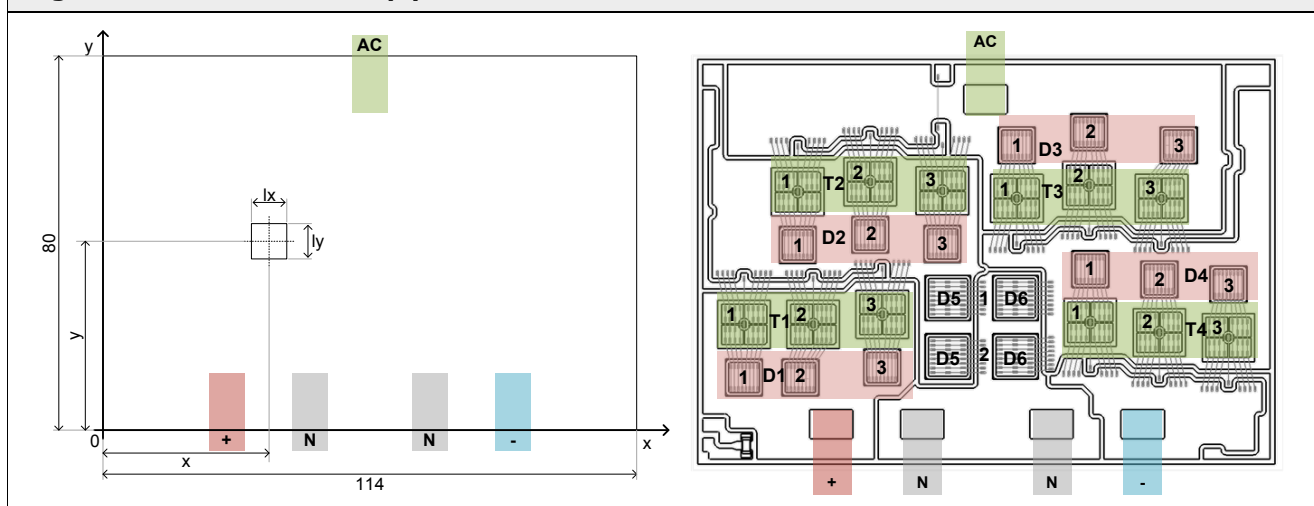

Table 5: Chip positions and dimensions of SKiM®4 MLI with minimum amount and size of chips

Module	Switch	Chip	x [mm]	y [mm]	lx [mm]	ly [mm]
SKiM®4 MLI	T1	1	9.4	27.6	-	-
		2	22.8	27.6	5.97	8.97
		3	36.5	29.6	5.97	8.97
	T2	1	19.8	53.9	-	-
		2	34.1	55.8	5.97	8.97
		3	48.4	53.9	5.97	8.97
	T3	1	63.0	52.5	5.97	8.97
		2	77.3	55.1	5.97	8.97
		3	91.6	52.5	-	-
	T4	1	77.5	28.0	5.97	8.97
		2	91.2	26.0	5.97	8.97
		3	104.8	25.0	-	-
	D1	1	9.4	17.1	-	-
		2	20.3	17.1	4.9	4.9
		3	36.5	19.1	4.9	4.9
	D2	1	19.8	43.4	-	-
		2	34.1	45.3	4.9	4.9
		3	48.4	43.4	4.9	4.9
	D3	1	63.0	63.0	4.9	4.9
		2	77.3	65.6	4.9	4.9
		3	95.0	63.0	-	-
	D4	1	77.5	38.5	4.9	4.9
		2	91.2	28.5	4.9	4.9
		3	104.8	29.5	-	-
D5	1	49.4	32.8	4.9	4.9	
	2	49.4	21.3	4.9	4.9	
D6	1	62.8	32.8	4.9	4.9	
	2	62.8	21.3	4.9	4.9	

Table 6: Chip positions and dimensions of SKiM®4 TMLI with minimum amount and size of chips

Module	Switch	Chip	x [mm]	y [mm]	lx [mm]	ly [mm]
SKiM®4 TMLI	T1	1	18.4	66.1	9.5	10.39
		2	18.4	53.8	9.5	10.39
		3	18.4	35.8	9.5	10.39
		4	18.4	20.2	9.5	10.39
	T2	1	42.3	29.2	10.39	9.5
		2	55.6	29.2	10.39	9.5
		3	71.8	29.2	10.39	9.5
	T3	1	42.3	50.8	10.39	9.5
		2	55.6	50.8	10.39	9.5
		3	68.8	50.8	10.39	9.5
	T4	1	96.2	68.1	9.5	10.39
		2	96.2	52.8	9.5	10.39
		3	96.2	37.5	9.5	10.39
		4	96.2	22.2	9.5	10.39
	D1	1	6.6	65.5	7.3	7.3
		2	6.6	50.2	7.3	7.3
		3	6.6	35.8	7.3	7.3
		4	6.6	20.8	7.3	7.3
	D2	1	42.3	19.1	7.3	7.3
		2	55.6	19.1	7.3	7.3
		3	71.8	19.1	7.3	7.3
	D3	1	42.3	61.9	7.3	7.3
		2	55.6	61.9	7.3	7.3
		3	68.8	61.9	7.3	7.3
	D4	1	84.4	68.7	7.3	7.3
		2	84.4	53.4	7.3	7.3
		3	84.4	36.9	7.3	7.3
		4	84.4	21.6	7.3	7.3

Figure 17: SKiM®4 TMLI chip positions

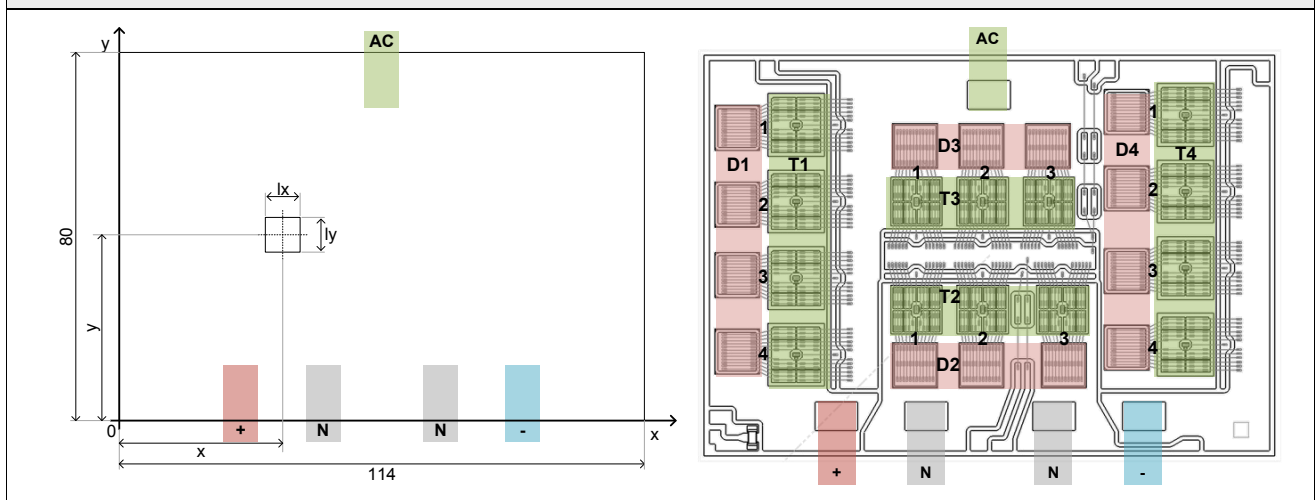

2.9 Thermal material data

For thermal simulations it is necessary to have the thermal material parameter, as well as the typical thickness of the different layers in the package. This data is given in Table 7. For better understanding, the sketch in Figure 18 shows the different layers in the package.

Table 7: Material data for thermal simulations

Layer	Material	Layer thickness [mm]	Spec. thermal conductivity [W/m*K]	Spec. thermal capacity [J/(kg*K)]	Density [kg/m ³]
1200V IGBT chip	Si	0.12	124	750	2330
650V IGBT chip	Si	0.08	124	750	2330
1200V Diode chip	Si	0.26	124	750	2330
650V Diode chip	Si	0.24	124	750	2330
Chip joint	Sn	~ 0.1	57	214	7800
DBC copper	Cu	0.4	310...390	385...420	7600...8960
DBC ceramic	Al ₂ O ₃	0.5	24	830	3780
DBC copper	Cu	0.4	310...390	385...420	7600...8960
Thermal paste	Customer specific	0.05	-	-	-
Heatsink	Customer specific	-	-	-	-

Figure 18: SKiM®4 sketch – cross section view

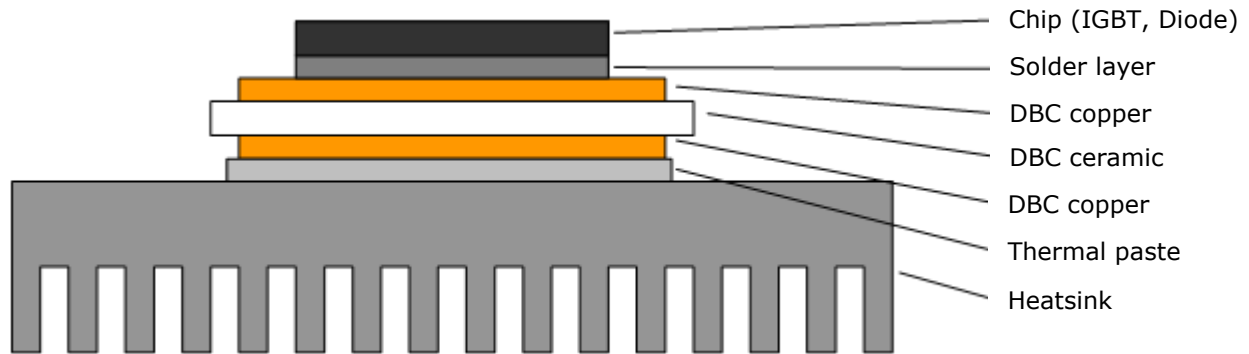

3. Chip Technologies and Product Ranges

3.1 Trench IGBT

The “Trench IGBT” chip design is based on a trench-gate structure combined with a “Field Stop” n^+ buffer layer for punch through feature, as shown in Figure 19.

The term “Punch-Through” describes the shape of the electric field inside the IGBT during blocking state. As shown in Figure 20, the electric field punches through the n^- layer into the n^+ layer. Inside the n^+ layer the field is steeper than in the n^- layer. Thanks to this, the PT-IGBT can be thinner than an NPT-IGBT (Figure 20) and the overall losses are lower. In the past, PT-IGBTs were made of “epitaxial” material and had a negative temperature coefficient for the forward voltage drop $V_{CE(sat)}$, making paralleling very difficult. State-of-the-art “Soft-Punch Through” and “Field Stop” PT-IGBTs, however, have a positive temperature coefficient and allow for parallel use.

Figure 19: IGBT concepts, basic properties

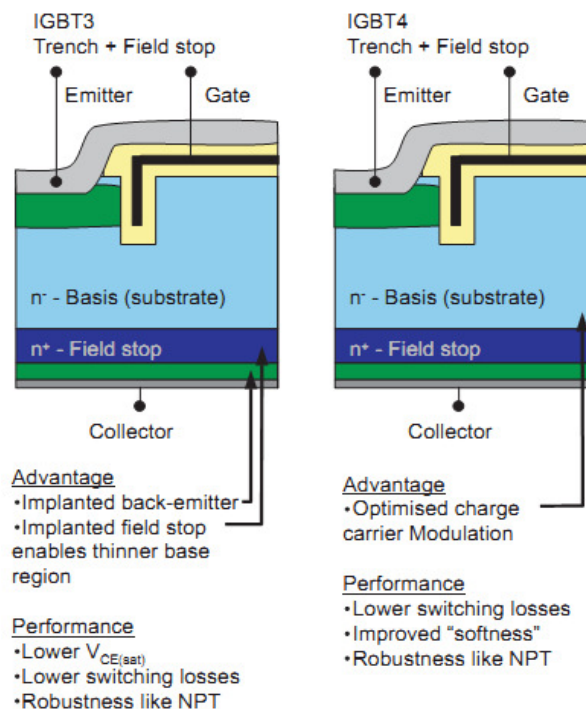
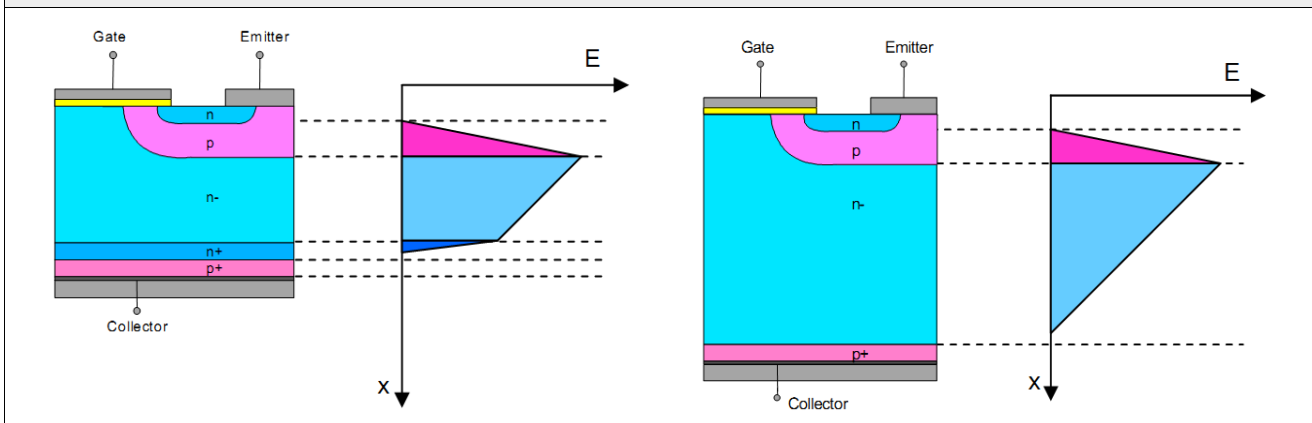

Figure 20: Punch-Through IGBT with planar gate (left), Non-Punch-Trough IGBT with planar gate (right)



With the introduction of the 4th generation, this general design was not changed, but the trade-off between the on-state losses $V_{CE(sat)}$ and the switching losses $E_{on} + E_{off}$ was optimized for operation with switching frequencies above 4kHz. Furthermore, the 1200V "IGBT4" is able to operate with a maximum junction temperature $T_{jmax} = 175^{\circ}C$. The increased T_{jmax} offers more flexibility in overload conditions or for applications with few temperature cycles (e.g. pumps or fans) where the junction temperature might now exceed the former limits.

For further information on "IGBT4", please refer to [3] and [4].

3.2 Inverse and Free-Wheeling diodes

The free-wheeling diodes used in SKiM® IGBT modules are specially optimized CAL (Controlled Axial Lifetime) diodes. These fast, "super soft" planar diodes are characterised by the optimal axial profile of the charge carrier life-time.

This leads to:

- low peak reverse current lowering the inrush current load on the IGBTs in bridge circuits
- "Soft" decrease in the reverse current across the entire operating temperature range, which minimizes switching surges and interference
- robust performance even when switching at high di/dt
- very good paralleling capability thanks to the negligible negative temperature coefficient and the small forward voltage (V_f) spread

SEMIKRON's newly developed "CAL4" diode is designed specifically for use with the "IGBT4" generation. This new device boasts low thermal losses and outstanding soft switching behaviour even at extreme commutation speeds. Further, the newly developed junction termination ensures safe operation up to $175^{\circ}C$.

For further information on CAL4, please refer to [5].

3.3 Operating areas for IGBTs

Safe operating areas are not included in the datasheets.

3.3.1 Safe Operating Area (SOA)

Safe operating area is defined as the voltage and current conditions for which the chip can operate without self-damaging during switching on.

Figure 21 shows the maximum curve $I_C = f(V_{CE})$ during single-pulse operation using a double logarithmic scale. The graph in Figure 21 refers to the limiting values of V_{CES} and I_{CRM} :

- maximum collector current \rightarrow horizontal limit
- maximum collector-emitter voltage \rightarrow vertical limit

It is important that the maximum ratings apply to currents which do not heat the IGBT to temperatures above the maximum chip temperature $T_j = 150^{\circ}C$ or $175^{\circ}C$. Only during switching operation IGBT modules

may touch the linear characteristic areas in the capacity of an active amplifier with $I_C = f(V_{CE})$. Linear operation over a longer period of time is not permitted, since this would involve local overload due to the variation in the transfer characteristics among the IGBT cell or paralleled chips.

Figure 21: SOA IGBT

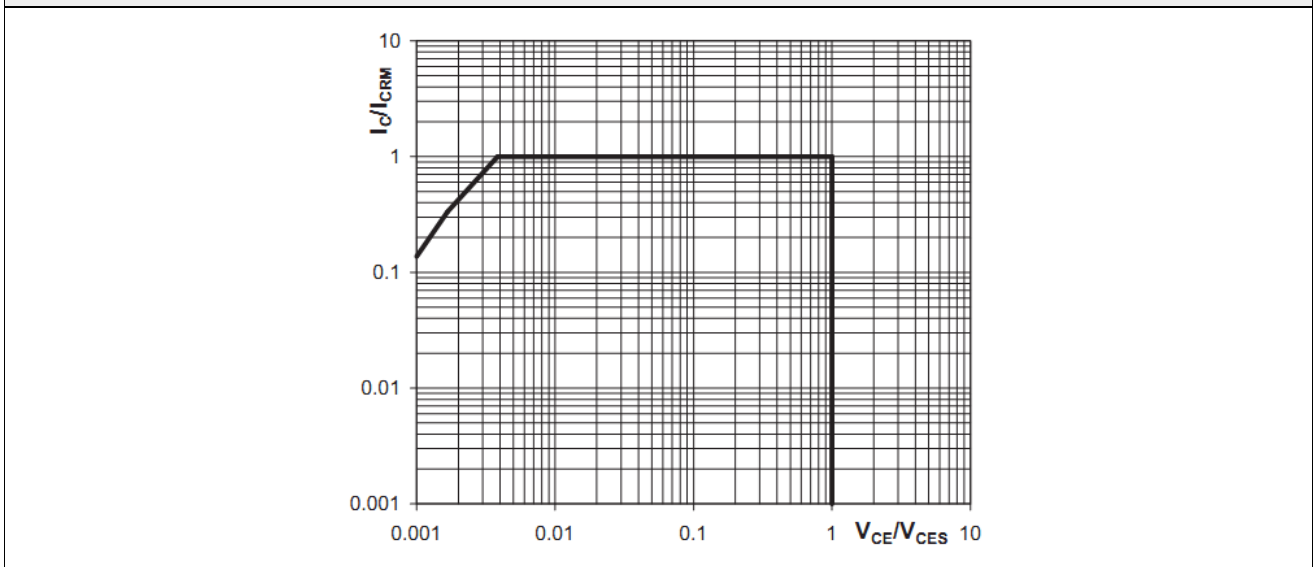

3.3.2 Reverse Bias Safe Operating Area (RBSOA)

Reverse Bias Safe Operating Area is the SOA curve during the device's turn-off state. Maximum V_{CES} must not be exceeded during turn-off. Due to the internal stray inductance, collector-emitter voltage to terminals ($V_{CEmax,T}$) must be smaller than the collector-emitter voltage at chip level (V_{CEmax}). This is the reason why the curve is cut in the upper right corner with respect to the curve at chip level.

The $V_{CEmax,T}$ can be calculated using the following formula where t_f can be calculated from data sheets:

$$V_{CE,max} - L_{CE} \cdot \left(\frac{I_C \cdot 0.8}{t_f(I_C)} \right)$$

An example of RBSOA curve is shown in Figure 22:

Figure 22: RBSOA IGBT

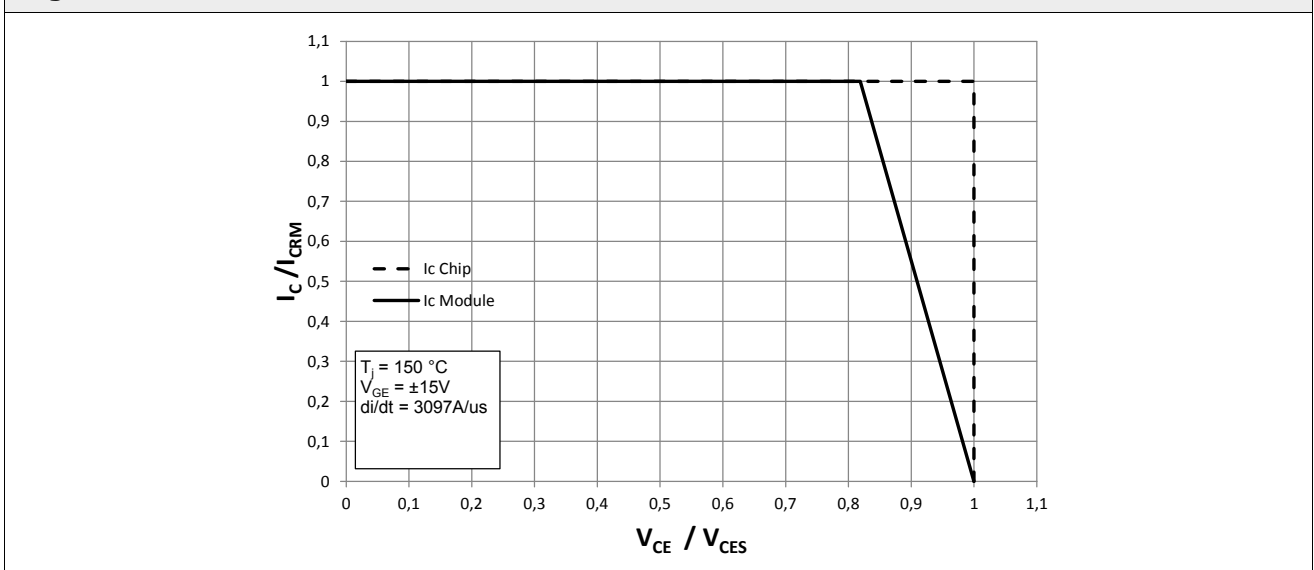

3.3.3 Short Circuit Safe Operating Area (SCSOA)

Under certain conditions, the IGBT is essentially capable of turning off short circuits actively. In doing so, high power losses are generated by the IGBT working in the active operating area, causing a temporary increase in chip temperature far beyond $T_{j,max}$. However, the positive temperature coefficient of the collector-emitter voltage causes the circuit to stabilize and the short-circuit current is limited to $4..6 \times I_{Cnom}$. Figure 23 gives an example of the permissible SCSOA. Here it must be taken into consideration that the maximum external voltage has to be reduced by the amount: $L_s \cdot di/dt$.

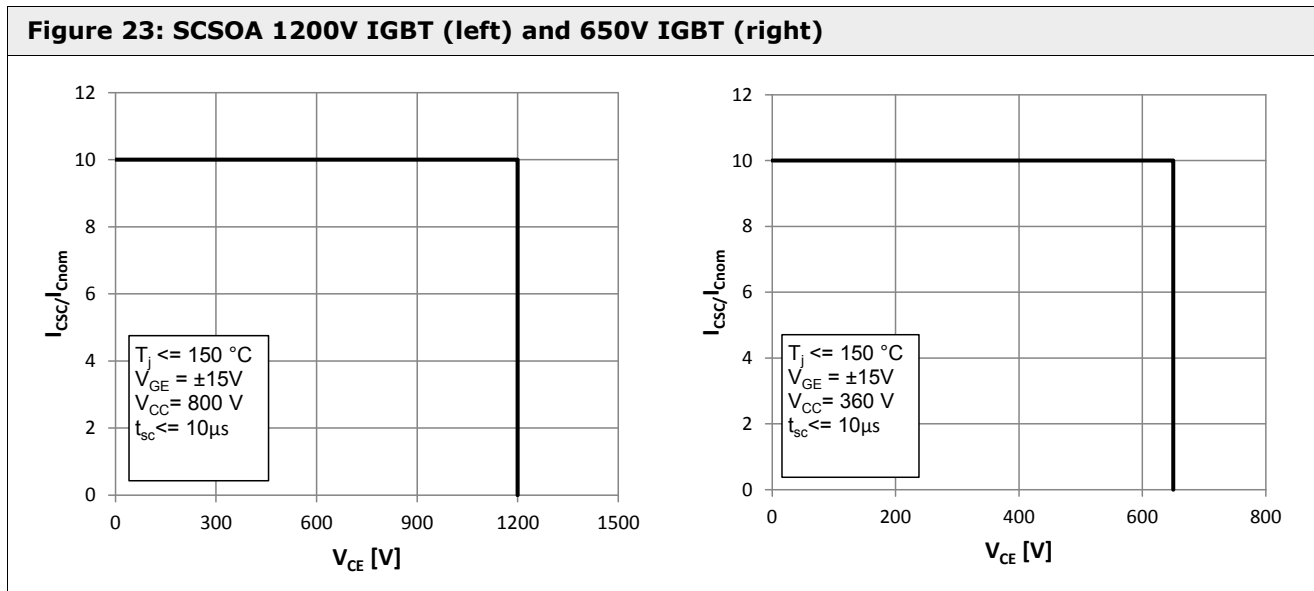

The following boundary conditions need to be fulfilled to guarantee safe operation:

- the short circuit must be detected and turned off within max. 10µs for 1700V, 1200V and within max. 6 µs for 650V IGBTs
- the time between two short circuits has to be at least 1s
- the IGBT must not be subjected to more than 1000 short circuits during its total operation time

3.3.4 Selection guide

The correct choice of the IGBT module depends very much on the application itself. A lot of different parameters and conditions need to be taken into account: $V_{in,r}$, $I_{in,r}$, $V_{out,r}$, $I_{out,r}$, $f_{sw,r}$, $f_{out,r}$, overload, load cycles, cooling conditions, etc.

Due to this variety of parameters a simplified selection guide is not seriously feasible. For this reason SEMIKRON offers the selection, calculation and simulation tool "SEMISEL" under <http://semisel.semikron.com>. Almost all design parameters can be edited for various input or output conditions. Different cooling conditions can be chosen and specific design needs can be effectively determined.

4. Temperature sensor and Isolation

The thermal resistance is defined as given in the following equation:

$$R_{th(1-2)} = \frac{\Delta T}{P_V} = \frac{(T_1 - T_2)}{P_V}$$

The data sheet values for the thermal resistances are based on measured values. As seen in the equation, the temperature difference ΔT has a major influence on the R_{th} value. As a result, the reference point and the measurement method have a major influence, too. Since SKiM® modules have no base plate, the typical case temperature (T_c) and hence the $R_{th(j-c)}$ value cannot be given. Instead, SEMIKRON gives the thermal resistance between the junction and the heatsink $R_{th(j-s)}$. This value depends largely on the thermal paste. Thus, the value is given for a reference paste in the data sheets.

SEMIKRON measures the $R_{th(j-s)}$ of SKiM® modules on the basis of the reference points given in Figure 24. The reference points are the following:

- T_j - The junction of the chip
- T_s - The heatsink temperature is measured via a thermocouple positioned in a drilled hole, 2mm underneath the module, directly under the chip. The value "2mm" is derived from our experience, which has shown that at this distance from the DBC ceramic, parasitic effects resulting from heatsink parameters (size, thermal conductivity etc.) are at a minimum and the disturbance induced by the thermocouple itself is negligible.

Figure 24: Location of reference point for R_{th} measurement as used for SKiM®

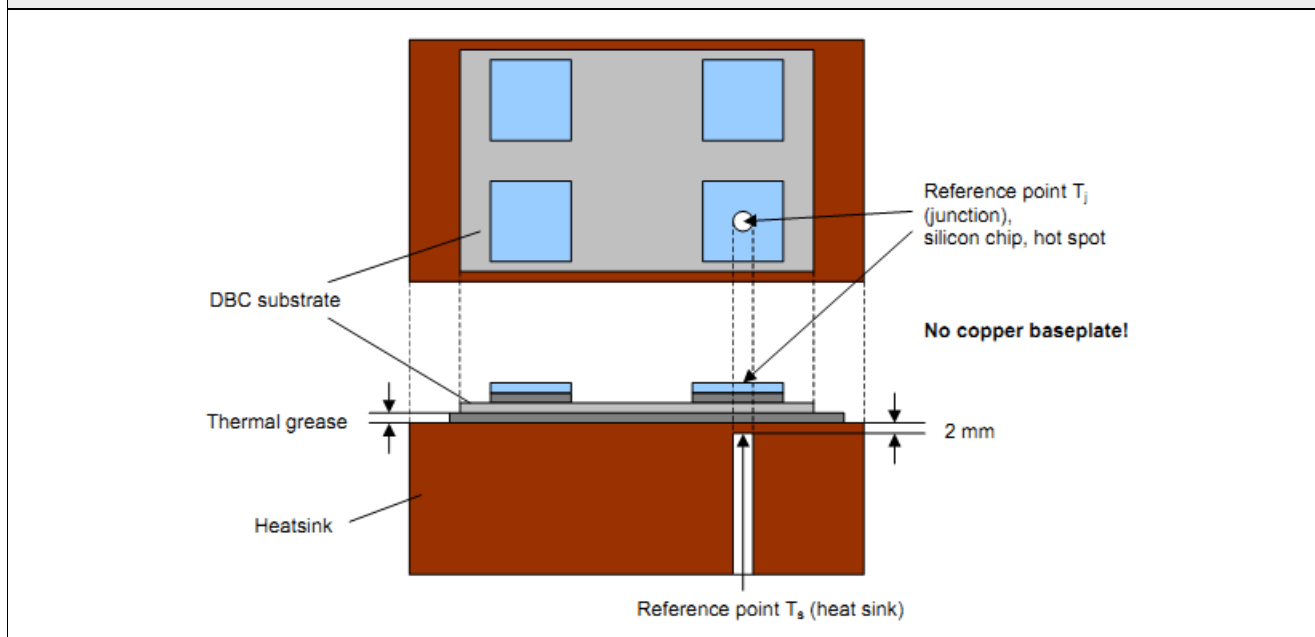

4.1 Transient thermal impedance

When switching on a "cold" module, the thermal resistance R_{th} appears smaller than the static value as given in the data sheets. This phenomenon occurs due to the internal thermal capacities of the package. These thermal capacities are "uncharged" and will be charged with the heating energy resulting from the losses during operation. In the course of this charging process the R_{th} value seems to increase. During this time it is therefore called transient thermal impedance Z_{th} . When all thermal capacities are charged and the heating energy has to be emitted to the ambience, the transient thermal resistance Z_{th} will have reached the static value R_{th} given in the data sheet. The advantage of this behaviour is the short-term overload capability of the power module.

Figure 25: Standardized transient thermal impedance of SKiM®4 MLI and SKiM®4 TMLI

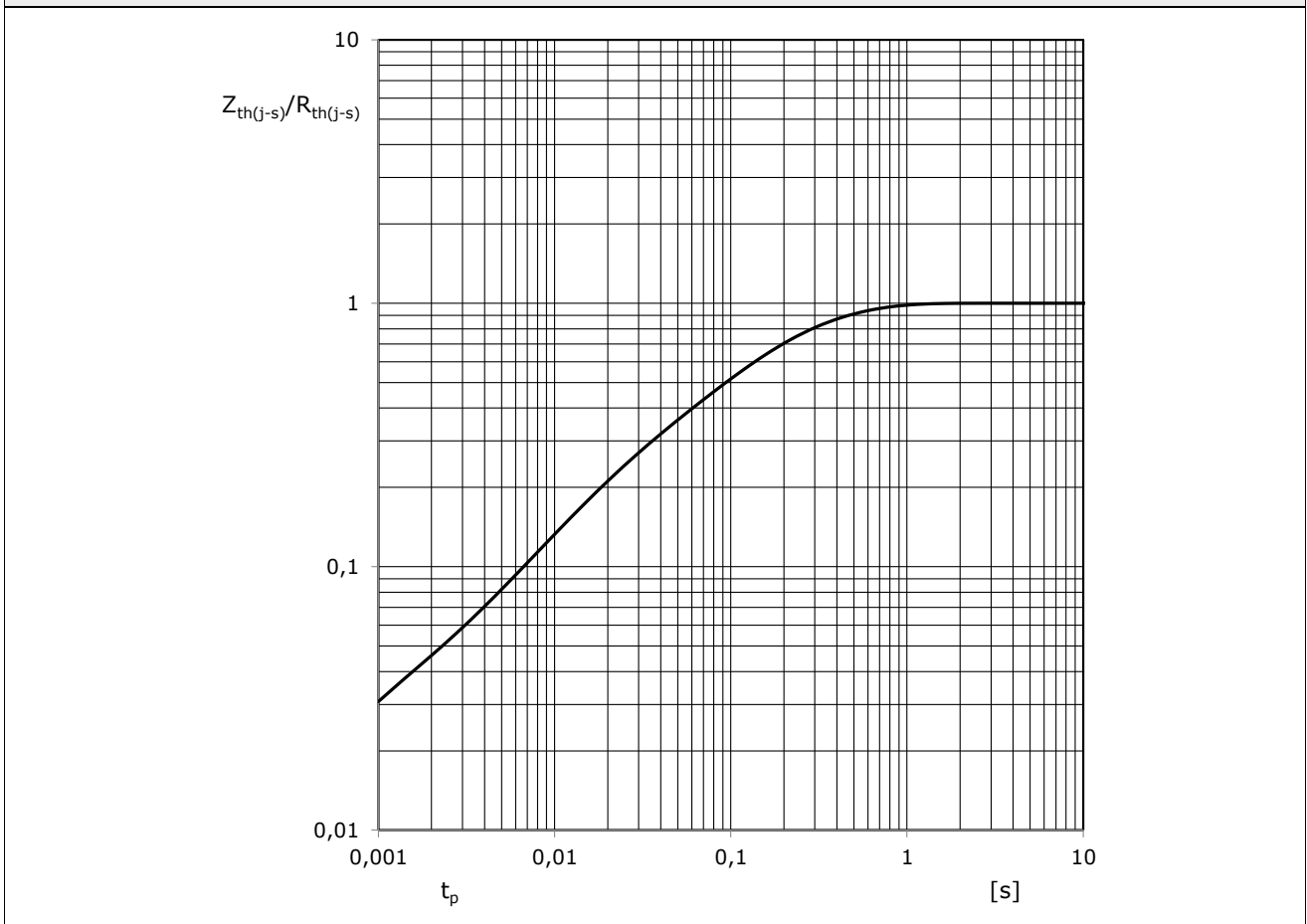

The transient thermal behaviour is measured during SEMIKRON’s module approval process. On basis of this measurement a mathematical model is derived, resulting in the following equation:

$$Z_{th(j-s)}(t) = \sum_{i=1}^4 R_i \cdot \left(1 - e^{-\frac{t}{\tau_i}}\right)$$

For SKiM®4 MLI and SKiM®4 TMLI the $Z_{th(j-s)}$ can be determined using the coefficients given in Table 8.

Table 8: Coefficients for calculating $Z_{th(j-s)}$ of SKiM®4 MLI and SKiM®4 TMLI

Parameter	Unit	Value
R_1	[K/W]	$0.45 \times R_{th(j-s)}$
R_2	[K/W]	$0.4 \times R_{th(i-s)}$
R_3	[K/W]	$0.13 \times R_{th(i-s)}$
R_4	[K/W]	$0.02 \times R_{th(i-s)}$
T_1	[s]	0.3
T_2	[s]	0.11
T_3	[s]	0.015
T_4	[s]	0.0005

5. Integrated Temperature Sensor Specifications

All SKiM® IGBT modules feature a temperature-dependent resistor for temperature measurement. The resistor is soldered onto the same DBC ceramic substrate near the IGBT and diode chips and reflects the actual case temperature.

Since the cooling conditions have a significant influence on the temperature distribution inside SKiM® modules, it is necessary to evaluate the dependency between the temperatures of interest (e.g. chip temperature) and the signal from the integrated temperature sensor.

5.1 Electrical characteristics

The temperature sensor has a nominal resistance of 5kΩ at 25°C.

The built-in temperature sensor in SKiM® is a resistor with a negative temperature coefficient (NTC). Its characteristic is given in Figure 26 according to the values shown in Table 9.

A mathematical approximation (in the range from 80°C to 150°C) for the sensor resistance as a function of temperature $R(T)$ is given by:

$$R(T) = R_{100} \cdot e^{[B_{100/125} \cdot (\frac{1}{T} - \frac{1}{T_{100}})]}$$

With:

- $R_{100} = 493\Omega$
- $B_{100/125} = 3550K$
- $T_{100} = 100^\circ C = 373.15K$

$$R(T) = 493\Omega \cdot e^{[3550K \cdot (\frac{1}{T} - \frac{1}{373.15K})]}$$

Figure 26: Typical characteristic of the SKiM®4 NTC temperature sensor

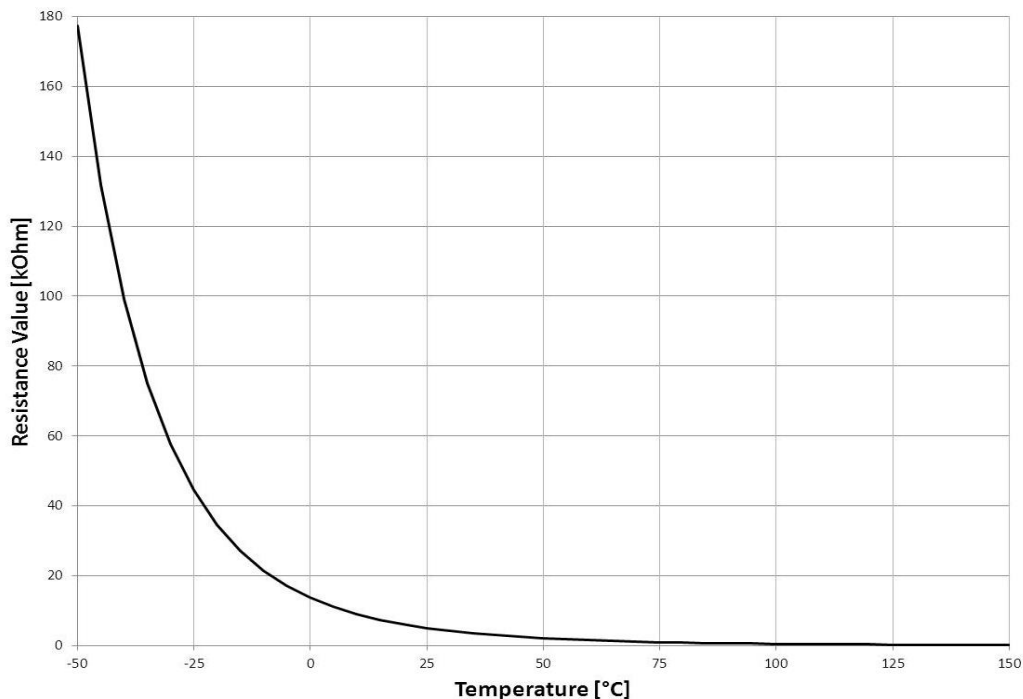
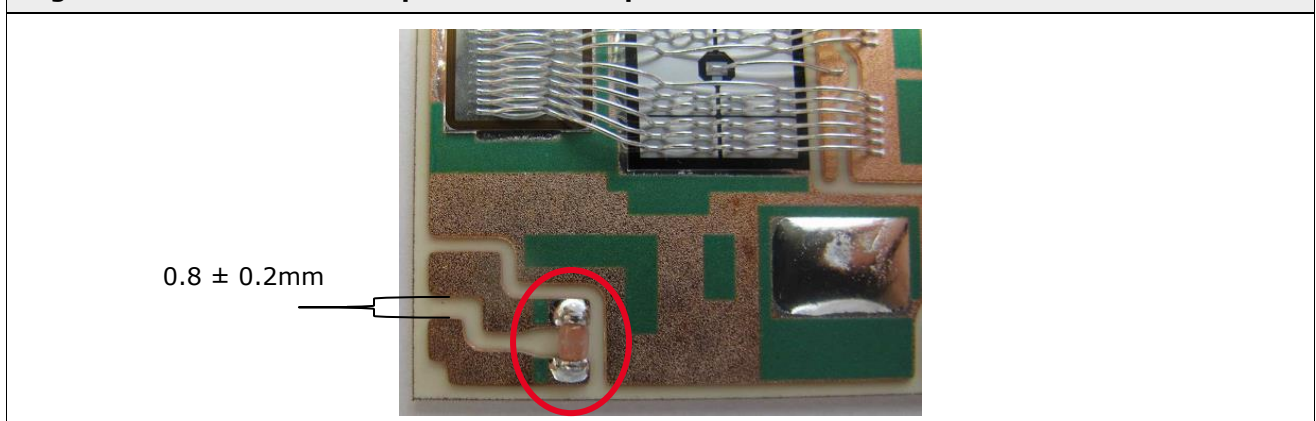

Table 9: NTC resistance values	
Temperature [°C]	NTC resistance value [kΩ]
-50	177.4
-40	99.09
-30	57.54
-20	34.06
-10	21.48
0	13.72
10	9.00
20	6.048
30	4.156
40	2.914
50	2.083
60	1.515
70	1.120
80	0.8404
90	0.6396
100	0.4933
110	0.3851
120	0.3042
130	0.2428
140	0.1959
150	0.1595

5.2 Electrical isolation

Inside SKiM® modules the temperature sensors are mounted close to the IGBT and diode dies onto the same substrate. The minimum distance between the copper conductors is $0.80 \pm 0.2\text{mm}$ (Figure 27).

Figure 27: SKiM®4 NTC temperature sensor position



According to EN 50178 (VDE 0160), this design does not provide "Safe Electrical Insulation", because the temperature sensor inside the SKiM® module might be exposed to high voltages during semiconductor short-circuit failure mode. After electrical overstress the bond wires could melt off, producing an arc with high-energy plasma in the process (as shown in Figure 28). In this case the direction of plasma expansion is unpredictable and the temperature sensor might come into contact with the plasma.

The safety grade "Safe Electrical Insulation" in accordance with EN 50178 can be achieved by different additional means, which are described in this standard in more detail.

Figure 28: Sketch of high energy plasma caused by bond wire melting



Please note, to ensure the electrical isolation V_{isol} stated in the data sheets, suitable measurements are performed during the production process.

6. Surface Specification

To obtain the maximum thermal conductivity of the module, heatsink and module must fulfil the following specifications.

6.1 Heatsink

Figure 29: Heatsink surface specifications

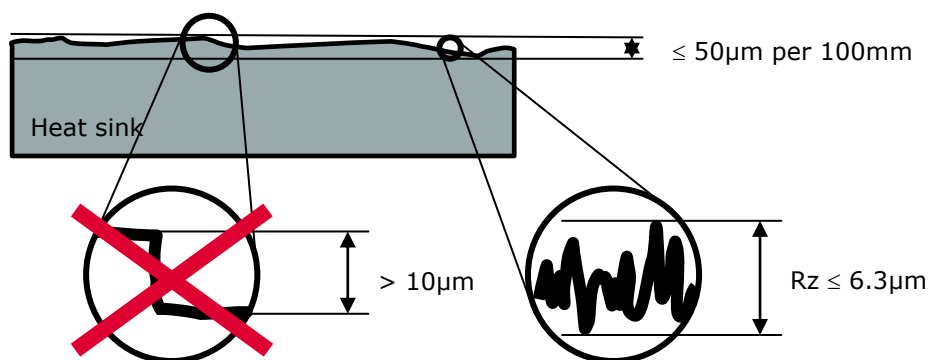

- Heatsink must be free from grease and particles
- Unevenness of heatsink mounting area must be $\leq 50\mu\text{m}$ per 100mm (DIN EN ISO 1101)
- Roughness (R_z) $\leq 6.3\mu\text{m}$ (DIN EN ISO 4287)
- No steps $> 10\mu\text{m}$ (DIN EN ISO 4287)

6.2 Mounting surface

The mounting surface of the SKiM® module must be free from grease and all kind of particles. Fingerprints or discolorations on the bottom side of the DBC (Figure 30) do not affect the thermal behaviour and cannot be rated as a failure criteria.

Due to rework or a second cleaning process, there might be imperfections on the bottom surface of the DBC. An imperfection of the surface does not affect the thermal behaviour (Figure 31).

Figure 30: SKiM® bottom surface discoloration

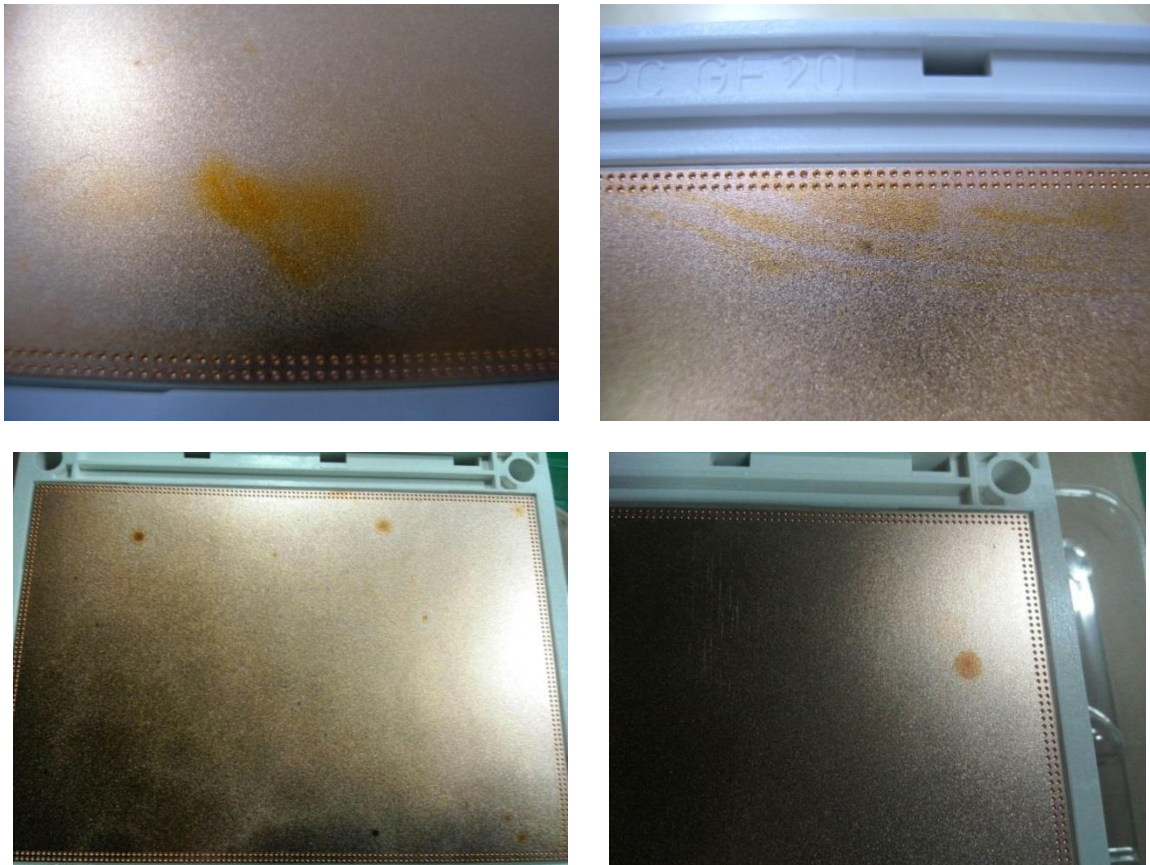

Figure 31: SKiM® bottom surface after rework



Due to the manufacturing process, the bottom side of the SKiM® may exhibit scratches, holes or similar marks. The following figures are defining surface characteristics, which do not affect the thermal behaviour. Distortions with higher values as specified can be rated as failure.

The SKiM® bottom surface must comply with the following specification (Figure 32 to Figure 34).

Figure 32: Scratches on the SKiM® surface

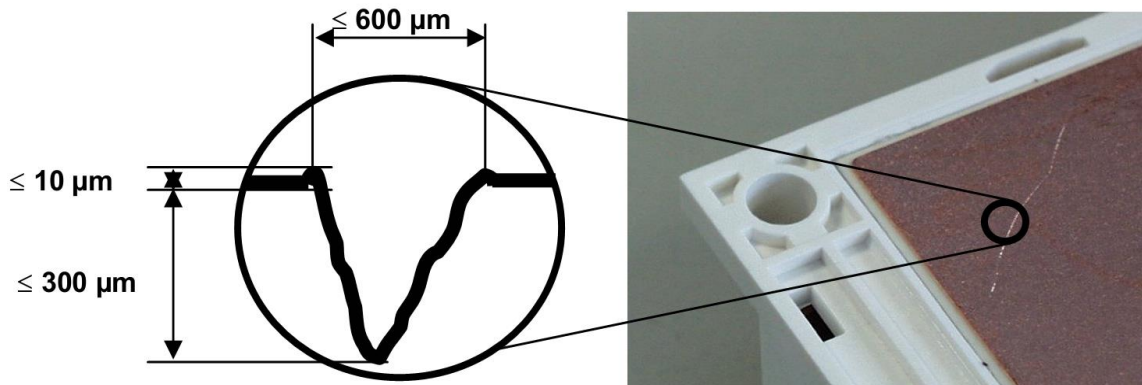

Figure 33: Etching hole (hole down to substrate level) in the SKiM® bottom surface

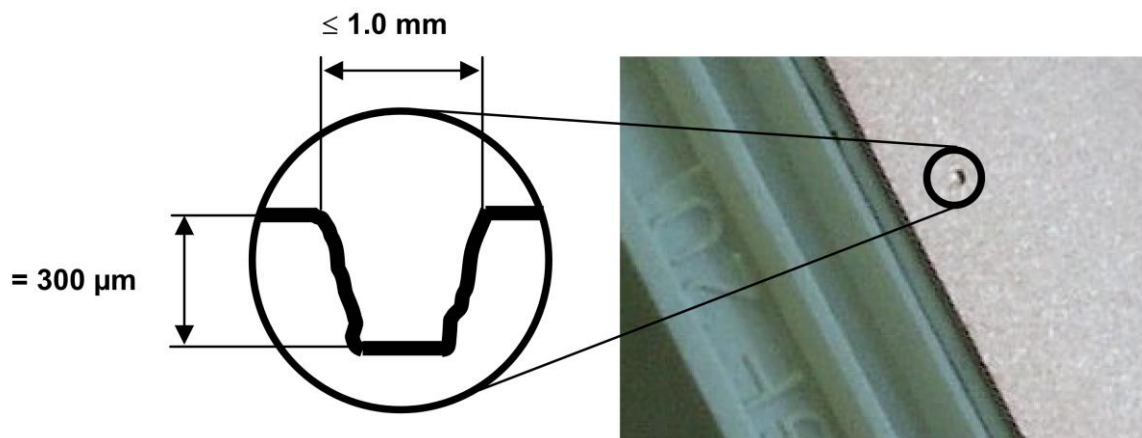
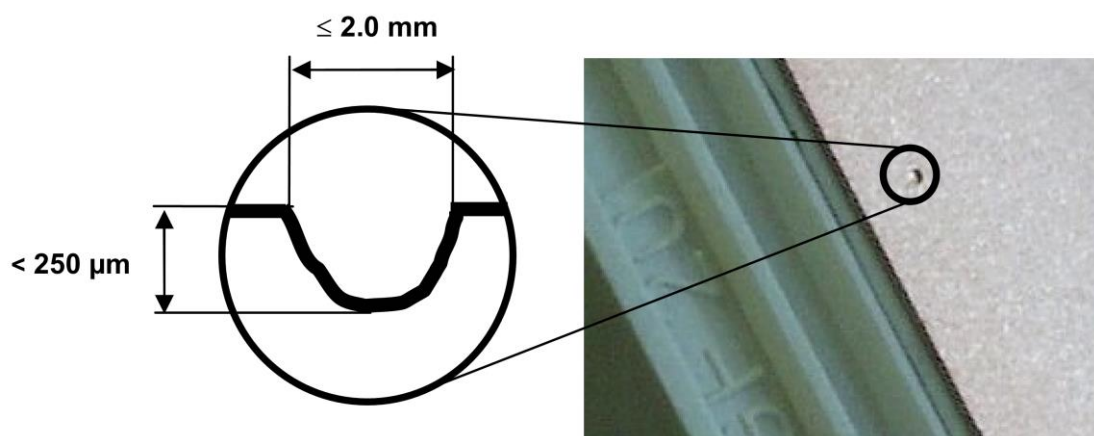

Figure 34: Etching hole (hole NOT down to substrate level) in the SKiM® bottom surface



7. Assembly

7.1 Application of thermal paste

Please refer to the Assembly Chapter of SKiM4 Mounting Instructions

7.2 Pre-applied thermal paste

SEMIKRON offers SKiM® power modules with pre-applied Wacker P12 (silicone-based) thermal paste.

Figure 35: SKiM®4 with pre-applied thermal paste



The thermal paste is applied to the modules by SEMIKRON prior to shipment for eliminating the critical process step from the customer's manufacturing process.

Further advantages of pre-applied thermal paste are:

- Efficient, reproducible, and controllable module assembly process
- Optimum thickness of thermal paste layer leading to lower thermal resistance
- High degree of process reliability using an automated and monitored screen-printing process

7.3 Mounting the SKiM®

SEMIKRON offers SKiM® power modules with pre-applied Wacker P12 (silicone-based) thermal paste.

After applying the thermal grease, the SKiM®4 or SKiM®5 module can be placed onto the appropriate heatsink area.

After the module has been positioned on the heatsink, the screws need to be inserted and pre-tightened, applying a torque of 0.5Nm.

SEMIKRON recommends to use the following M5 screw (according to DIN EN ISO 898-1):

Strength of screw	: "8.8"
Tensile strength	: $R_m = 800\text{N/mm}^2$
Yield point	: $R_e = 640\text{N/mm}^2$
Washer	: suitable for thread M5 (according to ISO 7092)

After the pre-tightening of the module SEMIKRON recommends a waiting time of 1-2 minutes until the module reaches mechanical stability before tightening the screws to the final mounting torque as shown in Table 10.

Table 10: Torque specification for heatsink fixing		
Module	Minimum torque	Maximum torque
SKiM®4	2Nm	3Nm
SKiM®5	2Nm	3Nm

Torque wrenches with automatic release are strongly recommended.

As to power screw drivers, an electric power screw driver is recommended. With pneumatic systems, the behaviour of the clutch can lead to a shock and torque overshoot which would damage the SKiM® module.

SEMIKRON recommends to limit the screwing speed to a maximum value of 200 revolutions per minute (rpm).

Pre-tightening and final tightening must be performed crosswise. Examples for crosswise mounting order of SKiM®4 and SKiM®5 are shown in Figure 36 and Figure 37.

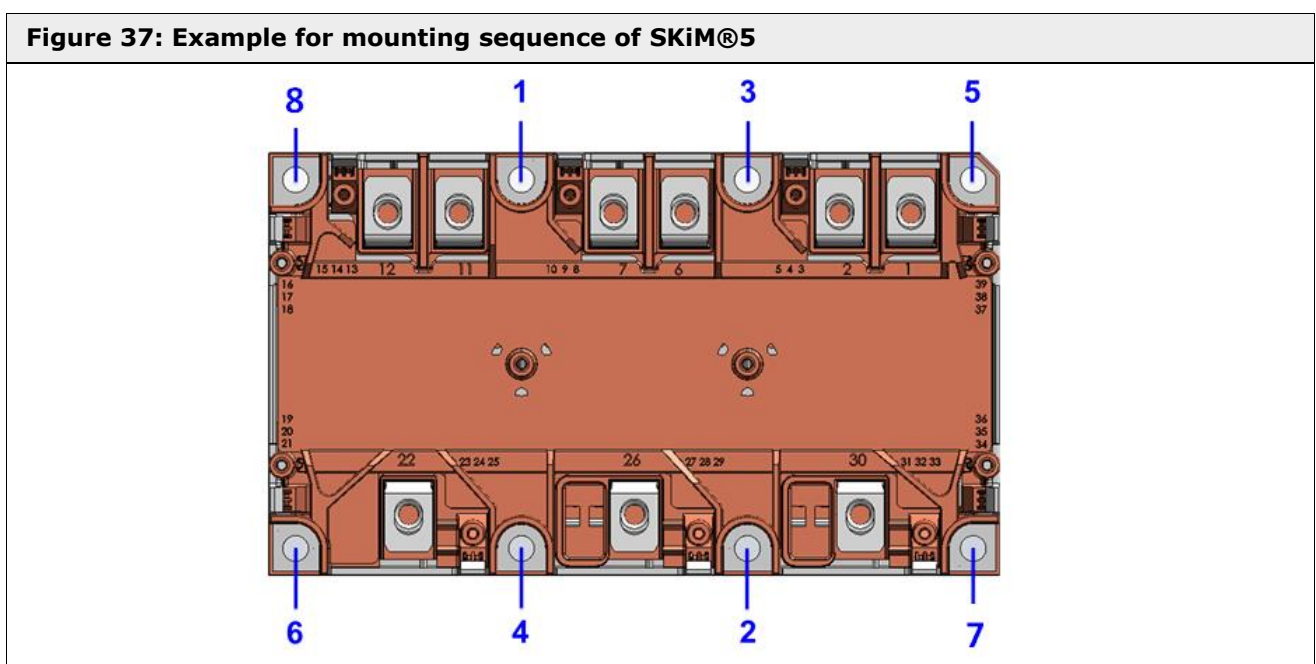
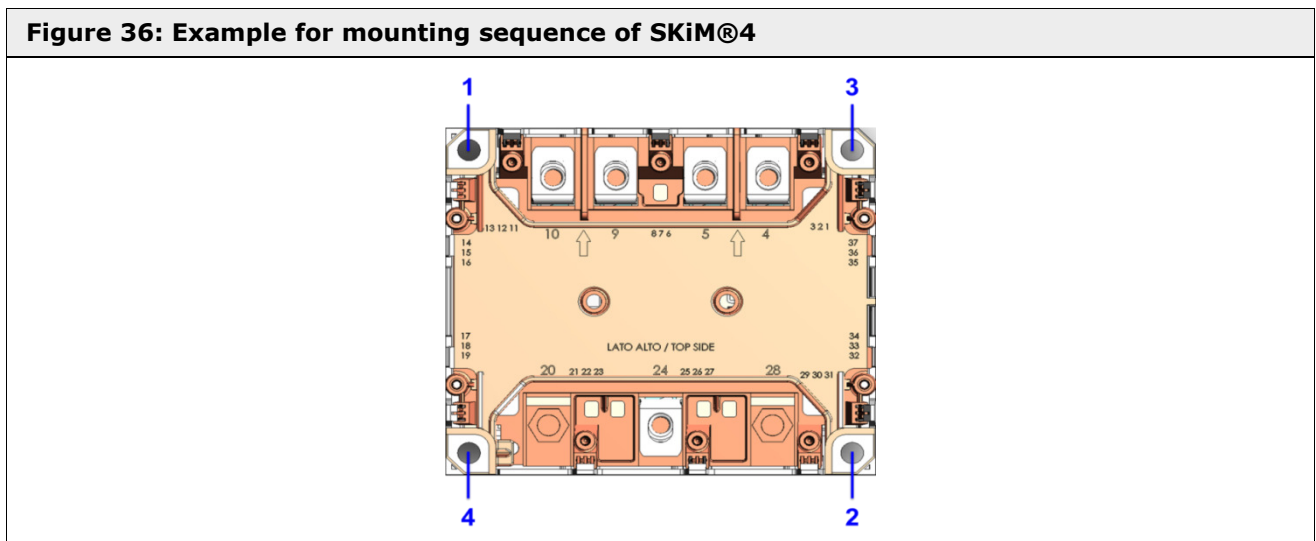

During the assembly process the thermal paste will spread evenly, meaning that reliable and homogeneous thermal contact is achieved. However, the steady-state R_{th} values given in the datasheets will be reached after 3-4 thermal cycles during which the heatsink temperature must be cycled between 10°C and 80°C. This effect shall be considered for first electrical high power operation.

7.4 Dismounting the SKiM® from the heatsink

Modules can be removed from heatsink following the steps shown in Table 11 using the following procedure:

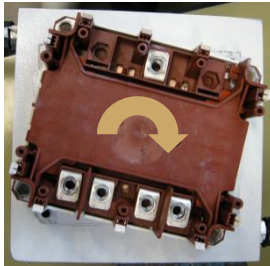
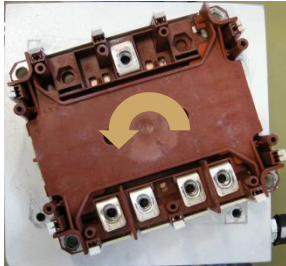
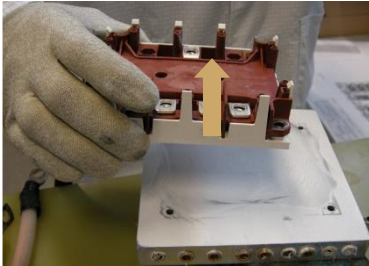
Table 11: Disassembling process for SKiM® modules	
Remove the mounting screws.	Wait some time to let the module mechanically relieve; heating the heatsink accelerates the relief process.
Turn the module to the right.	
Turn the module to the left.	
Pull the module away from the heatsink.	

SEMIKRON does not recommend to re-use the modules once they have been removed from the heatsink.

7.5 DC bus-bar mounting

The functionality of the pressure contact system can be disturbed by too high pulling forces on main terminals, resulting in malfunction of the module.

SEMIKRON recommends the following M6 screw (according to DIN EN ISO 898-1)

Strength Designation	: "8.8"
Tensile strength	: $R_m = 800N/mm^2$
Yield point	: $R_e = 640N/mm^2$
Washer	: not required

The screws have to be tightened to the final mounting torque according to Table 12.

Table 12: Torque specification for terminal mounting

Module	Minimum torque	Maximum torque
SKiM®4	4Nm	5Nm
SKiM®5	4Nm	5Nm

The maximum immersion depth of the screws for SKiM®4 and SKiM®5 may not exceed 9mm and subsequent tightening of the screws is not allowed.

For the maximum allowed pulling forces per terminal on SKiM®4 and SKiM®5 modules refer to Figure 38 and Table 13.

Figure 38: Terminal pulling forces

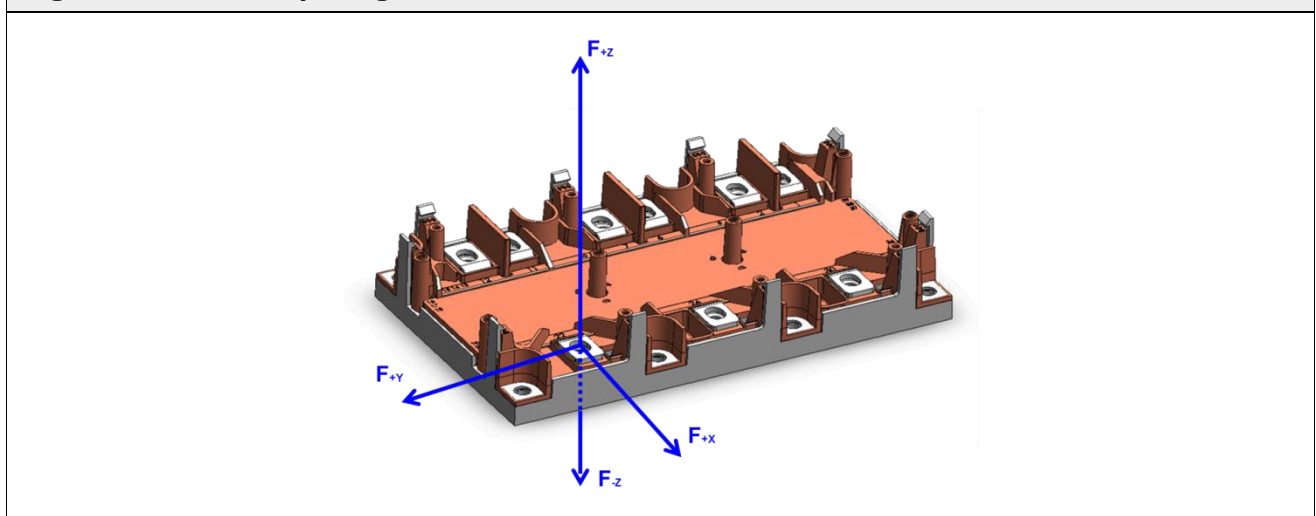
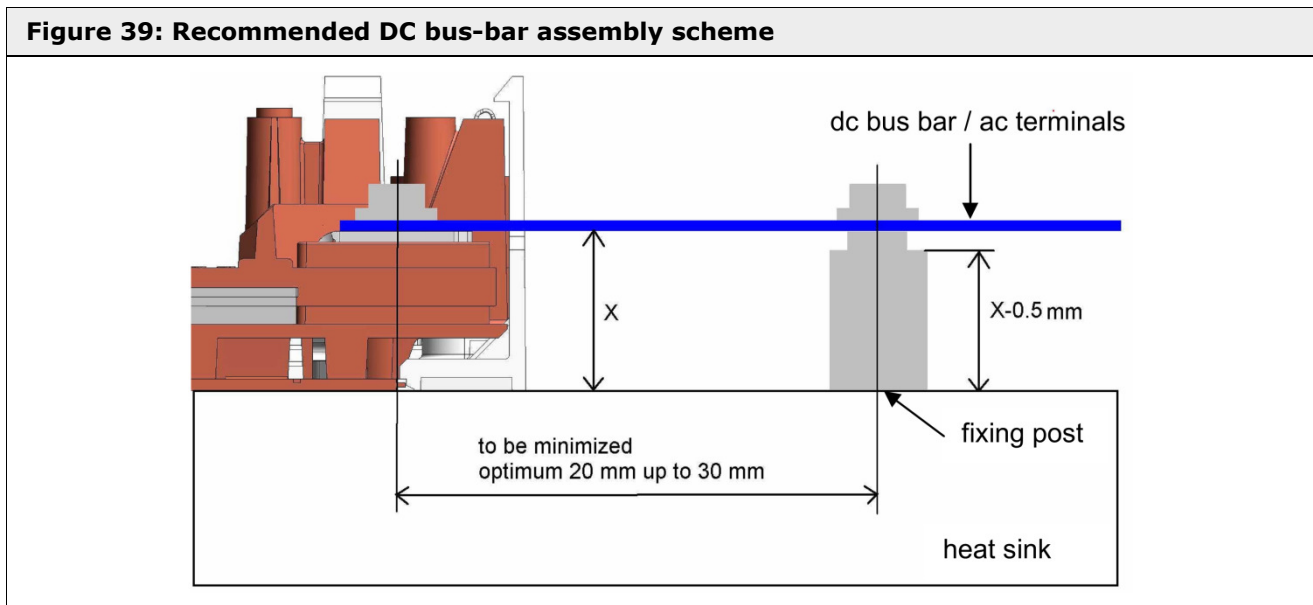

Table 13: Maximum pulling forces per terminal

Force direction	Maximum force
F_{+x}	< 100N
F_{+y}	< 100N
F_{+z}	< 100N

Note: In order to avoid damages to the module SEMIKRON recommends not to apply pulling forces along F_{+z} direction. To avoid those pulling forces it is recommended to reduce the height of the fixing post by 0.5mm in regards to the minimum terminal height (see Figure 39).

Figure 39: Recommended DC bus-bar assembly scheme



7.6 Printed Circuit Board (PCB)

7.6.1 PCB specifications

Recommendations for the printed circuit board:

- PCB thickness between 1.45mm and 2.0mm
- Minimum copper thickness of spring landing pads: 35µm
- The landing pads must not contain plated-through holes ("VIAs") to prevent contact deterioration
- In the remaining area VIAs can be used as desired
- The landing pads for the auxiliary contacts must be rectangular: 3,5mm x 4mm, gap 0,5mm (see also Figure 40)
- The maximum mechanical force used to mount the PCB on the SKiM® must be properly calibrated in order to avoid PCB or SMD component damages
- Approved surface for the landing pads is electro-less nickel with a final immersion gold layer (Ni+Au). Sufficient plating thickness must be guaranteed in accordance with the PCB manufacturing process. Not recommended for use are boards with "organic solder ability preservative" (OSP) passivation, because OSP is not suitable for guaranteeing long-term corrosion-free contact. The OSP passivation disappears during soldering or after approximately 6 months of storage.
- During the solder processes the landing pads for SKiM® spring contacts need to be covered and protected from contamination. This is particularly crucial for wave soldering. No residue of the cover material must be left on the landing pads as this could lead to deterioration of the electrical contact in the long term.

An example layout for a PCB fitting for the SKiM®4 is shown in Figure 40. A PCB with that layout will fit exactly on the SKiM® and provide all spring contact positions as well as mounting and screw holes.

Figure 40: Landing pads layout for SKiM®4

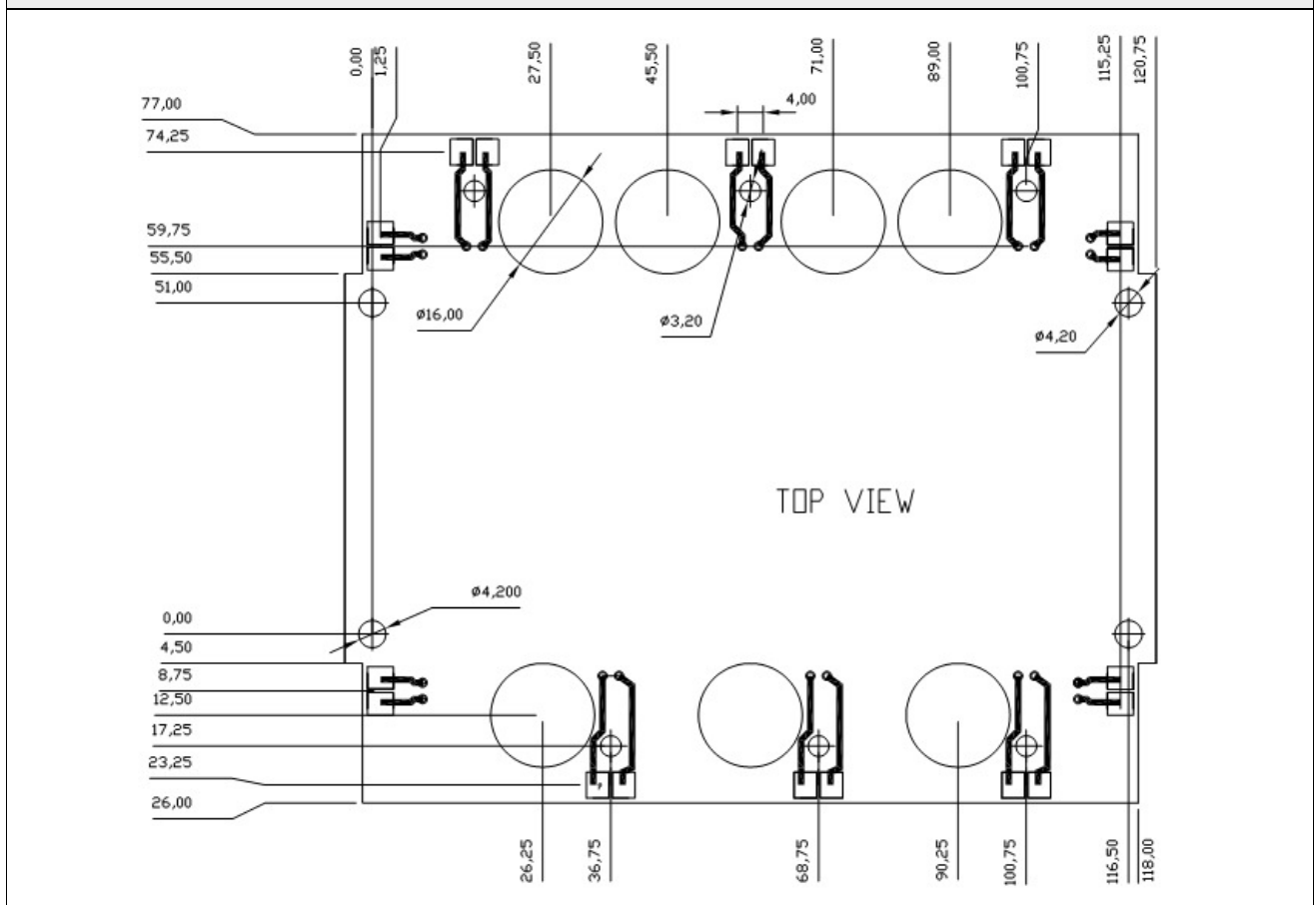

7.6.2 PCB assembly

A printed circuit board (PCB) can easily be mounted onto the SKiM® module by snapping in all snappers as shown in Figure 41.

Figure 41: PCB assembly on the SKiM®4

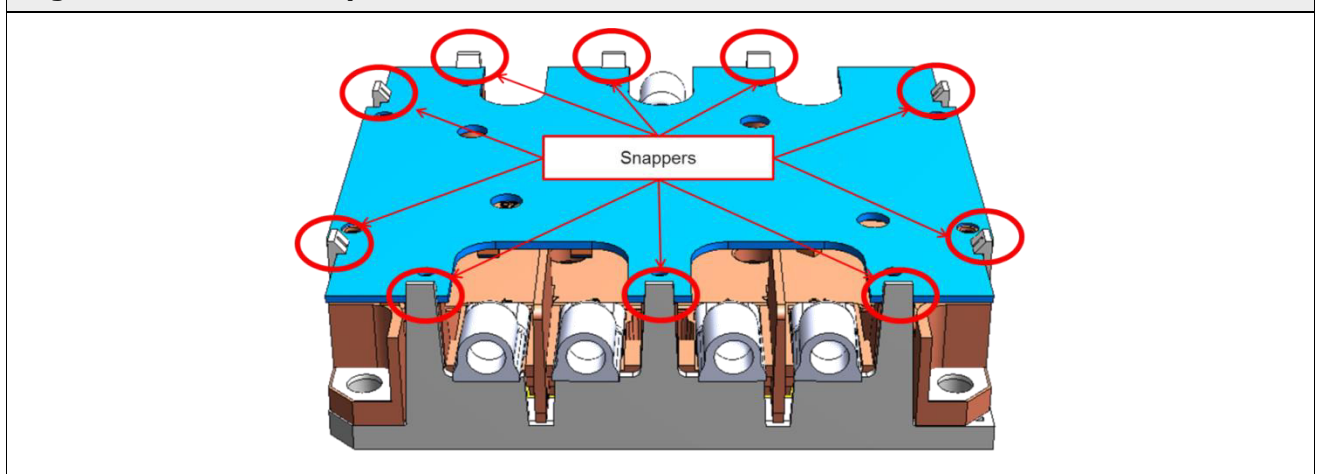

To test the SKiM®4 MLI and TMLI the following application boards have been developed:

- L5063101 – SKYPER® 42 LJ
- 45120701 – PCB MLI driver adaptor
- 45121301 – PCB TMLI driver adaptor

The application boards respect all required clearance and creepage distances but are not further qualified as they are intended for prototyping only and not for series production.

The complete assembly scheme is shown in Figure 42.

Figure 42: SKiM®4 driver application boards

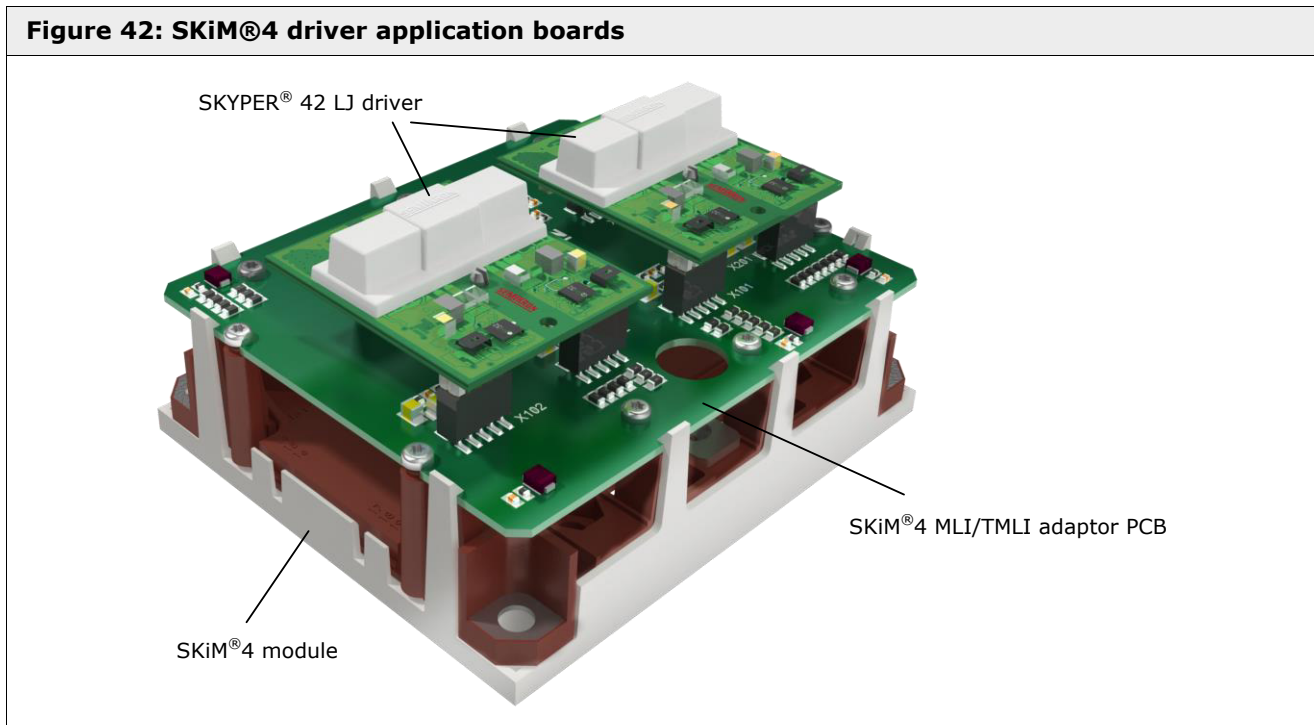

To avoid damages of the spring contacts during the assembly of the PCB adapter, it is recommended not to make lateral movements of the board in respect of the module. For this reason it is recommended to maintain the PCB aligned to the module using guiding pins (Figure 43) temporarily located in the posts shown in Figure 44.

The procedure to assemble the PCB using the guiding pins is as follows:

1. put at least 2 guiding pins into 2 diagonally opposite screw holes
2. place the PCB on top of the SKiM®4 module, so that the guiding pins go through 2 holes in the PCB
3. press the PCB down along the guiding pins until all snap hooks have snapped over the edge of the PCB
4. screw down all other screws and finally replace the guiding pins with screws

In this way the PCB cannot move during assembly and the landing pads for the springs will be in the right position.

The P/N of the guiding pins is 41076090.

Table 14 specifies the minimum and maximum torque values for the PCB mounting screws.

Table 14: Torque specification for PCB mounting		
Module	Minimum torque	Maximum torque
SKiM®4	0.7Nm	0.9Nm
SKiM®5	0.7Nm	0.9Nm

Figure 43: Guiding pin for SKiM®4

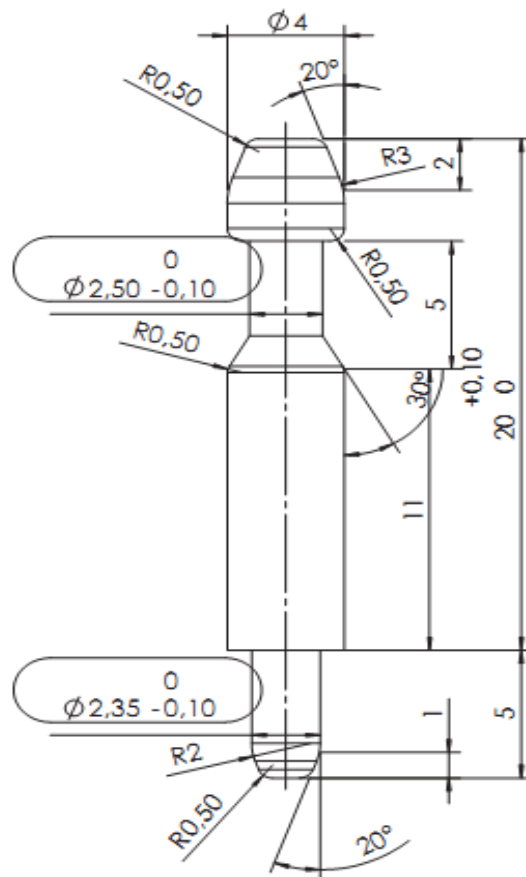

Figure 44: Guiding pin positions of SKiM®4

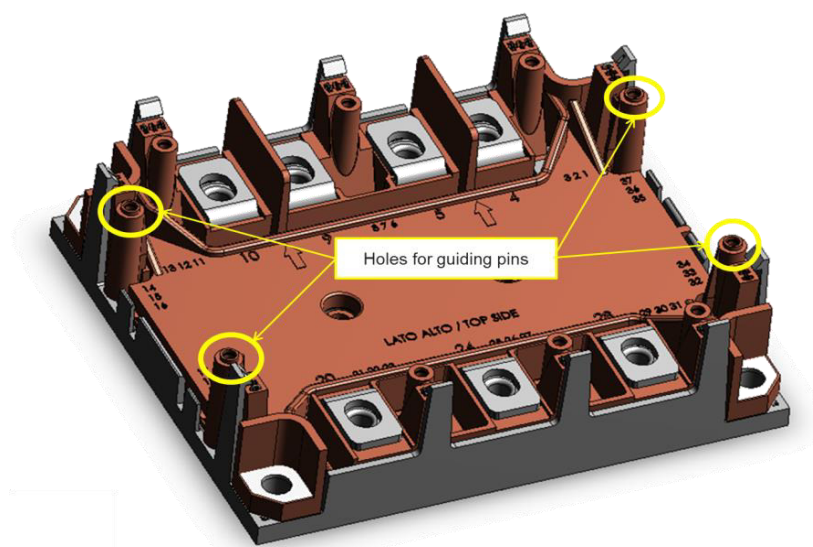
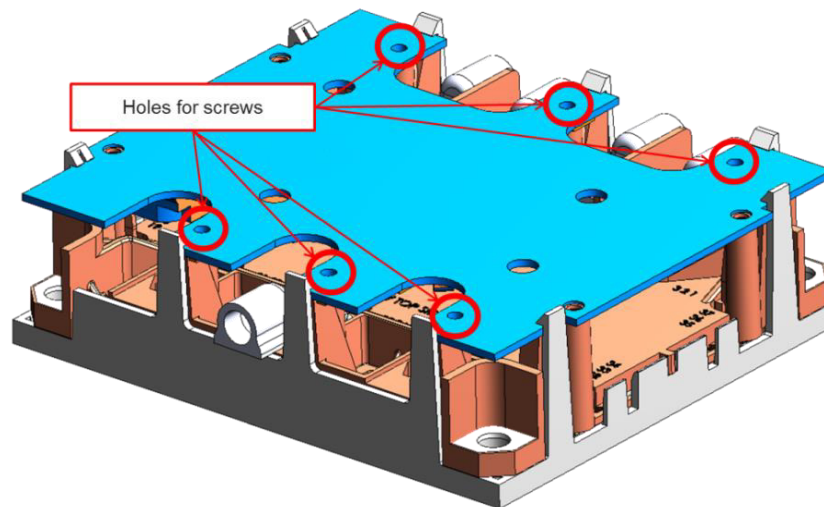

Figure 45: Final assembly of driver PCB



Once fixed on the Module the PCB can be removed and replaced only once. Fastening the self-tapping screws more than twice in the same hole may compromise the mechanical stability.

To fix the PCB onto the module SEMIKRON recommends the usage of the following screw:

- Screw: EJOT PT WN1452 K30x8 (self-tapping type)
- Screw head: the design can be chosen by the Customer

The recommended screws may be supplied by *EJOT Verbindungstechnik GmbH*:

- Web site: <http://www.ejot.de>
- E-mail: info@ejot.de

8. Spring Contact System Specifications

8.1 Spring and contact specifications

Table 15: Specification for SKiM® contact springs

	Rating / Specification
Material	CuSn6 F95 – DIN17682
Contact force	10N

8.2 PCB spring landing pad specifications

Table 16: Specifications for the surface metallization of SKiM® contact spring landing pads

HAL Sn	No minimum thickness	Intermetallic phases may be contacted
NiAu N	Ni ≥ 3µm, Au ≥ 20nm (electro less nickel, immersion gold)	Tight Ni diffusion barrier required

8.3 Storage conditions

SKiM®4&5 products are qualified according to IEC 60721-3-1 and can therefore be stored in original package for maximum 2 years starting from date code under climatic class 1K2. So the following frame conditions apply

Table 17: Storage conditions	
Storage temperature	5°C ... 40°C
Relative humidity	5% ... 85%
Duration	2 years
Climatic class	1K2 (IEC 60721-3-1)
Condensation	Not allowed at any time

SKiM®4&5 products have been tested for climatic conditions in their original packaging. Packaging is very often limiting the allowed climatic conditions. So there are less restrictive conditions for the products itself. Due to our experience the temperature range mentioned in IEC 60721-3-1 for 1K2 can be enlarged for transportation and storage. So the following conditions are possible ⁽¹⁾:

Table 18: Shelf life conditions ⁽¹⁾	
Relative humidity	Max. 85%
Storage temperature	-25°C ... +60°C
Condensation	Not allowed at any time
Storage time	Max. 2 years

Please note that a higher temperature load can decrease storage time, in extreme cases down to half a year.

More restrictive storage conditions for products with pre-applied thermal interface material may apply and are mentioned in the dedicated documentation.

¹) These conditions have not explicit been tested by Semikron

9. Reliability

9.1 Standard tests for the qualification of SKiM®4&5 modules

The objectives of the test program (refer to Table 19) are:

1. Assure the general product quality and reliability
2. Evaluate design limits by stressing under a variety of testing conditions
3. Ensure the consistency and predictability of the production processes
4. Appraise process and design changes regarding their effect on reliability

Table 19: SEMIKRON standard qualification tests		
Reliability test	Test conditions (*)	Standard
High Temperature Reverse Bias (HTRB)	$V_{CE} = 95\% V_{CE,max}$; $T_C = 140^\circ\text{C}$ 1000h	IEC 60747
H3TRB	$V_{CE} = 80\text{ V}$; 85°C , 85% RH; 1000h, $V_{GE} = 0\text{V}$	IEC 60068-2-67
High Temperature Storage (HTS)	1000h; $T_{std,max} = +125^\circ\text{C}$	IEC 60068-2-2
Low Temperature Storage (LTS)	1000h; $T_{std,min} = -40^\circ\text{C}$	IEC 60068-2-1
Thermal Cycling (TC)	100 cycles; $-40^\circ\text{C} - +125^\circ\text{C}$	IEC 60068-2-14 Test Na
Power Cycling (PC)	20000 load cycles; $\Delta T_i = 100\text{K}$	IEC 60749-34
Vibration	Sinusoidal sweep; 5g; 2h per axis (x, y, z)	IEC 60068-2-6 Test Fc
Mechanical Shock	Half sine pulse; 30g; 3 times each direction ($\pm x$, $\pm y$, $\pm z$)	IEC 60068-2-27 Test Ea

(*) The test conditions do not necessary reflect the maximum capability of the product. The actual characteristics of the products are indicated in the data sheet.

9.2 Reliability of spring contacts

The SKiM® spring contact for the auxiliary connections is a solder-free contact. It can therefore be compared with other solder-free contacts such as screw terminals or plug connectors.

The surface materials for the spring contacts as given in Table 15 and Table 16 (Sn-plated spring and, for example, tin surface for PCB landing pads) are based on "state-of-the-art" knowledge as gained from long-term experience with plug connectors and SEMIKRON's long-term experience with spring connections. SKiM® modules passed all SEMIKRON standard reliability tests as given in Table 19 demonstrating the outstanding reliability of SEMIKRON's spring contacts.

Besides this, SEMIKRON performed additional tests to prove the spring contact reliability:

- Salt fog test - Figure 46
- Harmful gases test - Figure 47
- Vibration tests - Figure 48, Figure 49

Figure 46: Salt fog test

Elektro-, Maschinen- und Anlagentechnik
UMWELTSIMULATION

LGAD
Leitungs- und Anlagenbau
Technik-Service-Systeme
Nürnberg, 18. Januar 2002

Leitungs- und Anlagenbau
SEMIGAS
SEMIGAS

Leitungs- und Anlagenbau
SEMIGAS
SEMIGAS

SEMIGAS
Elektronik GmbH
Herr Dr. U. Scheuermann
Sigmundstr. 200
90431 Nürnberg

UNTERSUCHUNGSBERICHT Nr.: E 2.893

Auftrag: Salzspritztest nach DIN EN 60068-2-11, Ka
Auftr. Nr.: 101/DE 10373 vom 12. Dezember 2001
Gegenstand: 4 Stück Module SKIM4
Nr. MA0111/54 Nr. 5, 6, 7 und Nr. 8



UB_E2103_Semikron_Salzspritztest 1 von 4
L.G.A. + EMA-UMS + Tillystraße 2 + D-90431 Nürnberg
Tel.: (09 11) 8 55-57 20 + Fax: (09 11) 8 55-5744 +

Informationen über die LGA
sind im Internet zu finden.
<http://www.lga.de>

Elektro-, Maschinen- und Anlagentechnik
UMWELTSIMULATION

LGAD
Leitungs- und Anlagenbau
Technik-Service-Systeme
Nürnberg, 18. Januar 2002

Leitungs- und Anlagenbau
SEMIGAS
SEMIGAS

Leitungs- und Anlagenbau
SEMIGAS
SEMIGAS

SEMIGAS
Elektronik GmbH
Herr Dr. U. Scheuermann
Sigmundstr. 200
90431 Nürnberg

1. Versuchsangaben zum durchgeführten Salzspritztest:

Kammertemperatur: 35° ±2°C
NaCl-Konzentration: 50 g/l ±5
pH-Wert: 6,5 bis 7,2
Prüfdauer: 24 Stunden

2. Vereinbarung / Feststellung:

Die elektrische Vor- und Nachprüfung wird von der Firma SEMIKRON, Nürnberg, durchgeführt.

Eine ausführliche Funktions- und Sichtprüfung wird/wurde durch die Firma SEMIKRON, Nürnberg, durchgeführt.

LGA - Bereich Produkte
Referat: EMA - UMS
Umweltsimulation
i.A.

Dipl.-Ing. G. Windmüller
Referent

Die Untersuchungsgebühren sind nur für die eingangs erwähnten Prüflinge gültig.
Eine Vervielfältigung, auch nur auszugsweise, des Untersuchungsberichtes ist nicht zulässig.

Anlage:
1. Versuchsaufbau
2. Prüflinge nach der Salzspritztestprüfung

UB_E2103_Semikron_Salzspritztest 2 von 4
L.G.A. + EMA-UMS + Tillystraße 2 + D-90431 Nürnberg
Tel.: (09 11) 8 55-57 20 + Fax: (09 11) 8 55-5744 +

Informationen über die LGA
sind im Internet zu finden.
<http://www.lga.de>

Figure 47: Harmful gas test

Elektro-, Maschinen- und Anlagentechnik
UMWELTSIMULATION

LGAD
Leitungs- und Anlagenbau
Technik-Service-Systeme
Nürnberg, 22. März 2002

Leitungs- und Anlagenbau
SEMIGAS
SEMIGAS

Leitungs- und Anlagenbau
SEMIGAS
SEMIGAS

SEMIGAS
Elektronik GmbH
Herr Dr. U. Scheuermann
Sigmundstr. 200
90431 Nürnberg

UNTERSUCHUNGSBERICHT Nr.: E 2.892

Auftrag: Schadgasprüfung nach DIN EN 60068-2-60, Ka, Methode 3
Auftr. Nr.: 101/DE 10373 vom 12. Dezember 2001
Gegenstand: 4 Stück Module SKIM4
Nr. MA0111/54 Nr. 1, 2, 3 und Nr. 4



UB_E2102_Semikron_Mischgas_Kornelob 1 von 2
L.G.A. + EMA-UMS + Tillystraße 2 + D-90431 Nürnberg
Tel.: (09 11) 8 55-57 20 + Fax: (09 11) 8 55-5744 +

Informationen über die LGA
sind im Internet zu finden.
<http://www.lga.de>

Elektro-, Maschinen- und Anlagentechnik
UMWELTSIMULATION

LGAD
Leitungs- und Anlagenbau
Technik-Service-Systeme
Nürnberg, 22. März 2002

Leitungs- und Anlagenbau
SEMIGAS
SEMIGAS

Leitungs- und Anlagenbau
SEMIGAS
SEMIGAS

SEMIGAS
Elektronik GmbH
Herr Dr. U. Scheuermann
Sigmundstr. 200
90431 Nürnberg

1. Schadgasprüfung nach DIN EN 60068-2-60:

Einzelbestimmung: Mehrkomponentenklima
Konzentration: 0,1 ppm H₂S
0,2 ppm NO₂
0,02 ppm Cl₂
Umgebungstemperatur: 30°C
rel. Luftfeuchte: 75 %
Volumenstrom: 1 m³ pro Stunde
Prüfdauer: 21 Tage

2. Vereinbarung

Die elektrische Vor- und Nachprüfung wird von der Firma Semikron, Nürnberg, durchgeführt.

3. Feststellung

An den Prüflingen sind äußerlich keinerlei Schäden wie Materialbruch, Risse oder Deformationen feststellbar.

LGA - Bereich Produkte
Referat: EMA - UMS
Umweltsimulation
i.A.

Dipl.-Ing. G. Windmüller
Referent

Die Untersuchungsgebühren sind nur für die eingangs erwähnten Prüflinge gültig.
Eine Vervielfältigung des Untersuchungsberichtes, auch nur auszugsweise, ist nicht zulässig.

UB_E2102_Semikron_Mischgas_Kornelob 2 von 2
L.G.A. + EMA-UMS + Tillystraße 2 + D-90431 Nürnberg
Tel.: (09 11) 8 55-57 20 + Fax: (09 11) 8 55-5744 +

Informationen über die LGA
sind im Internet zu finden.
<http://www.lga.de>

Figure 48: Vibration test 1

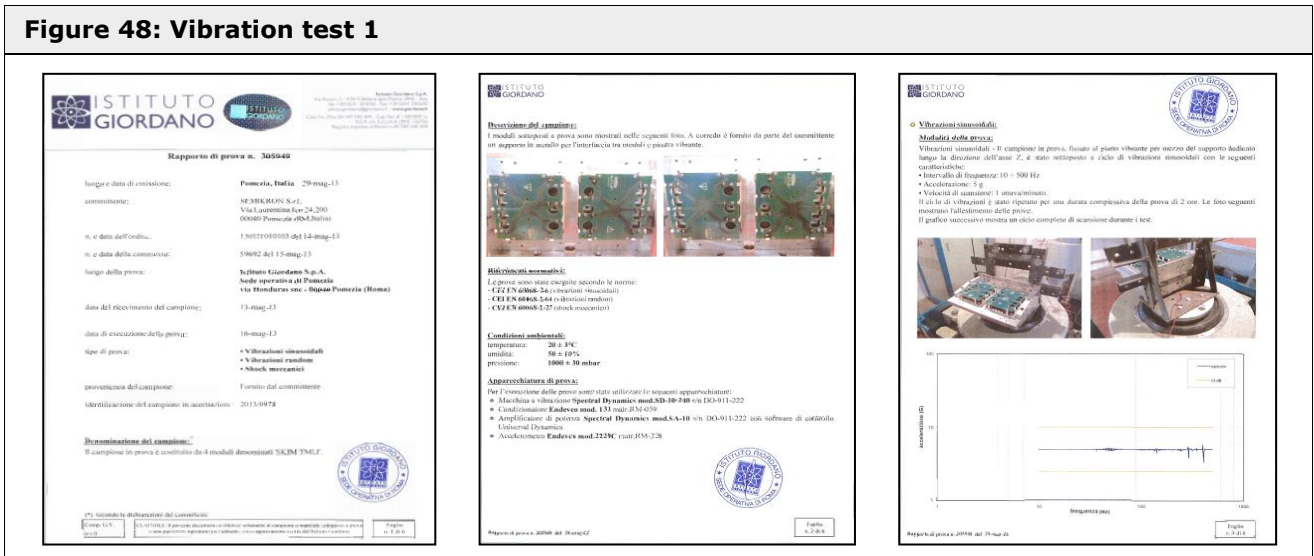
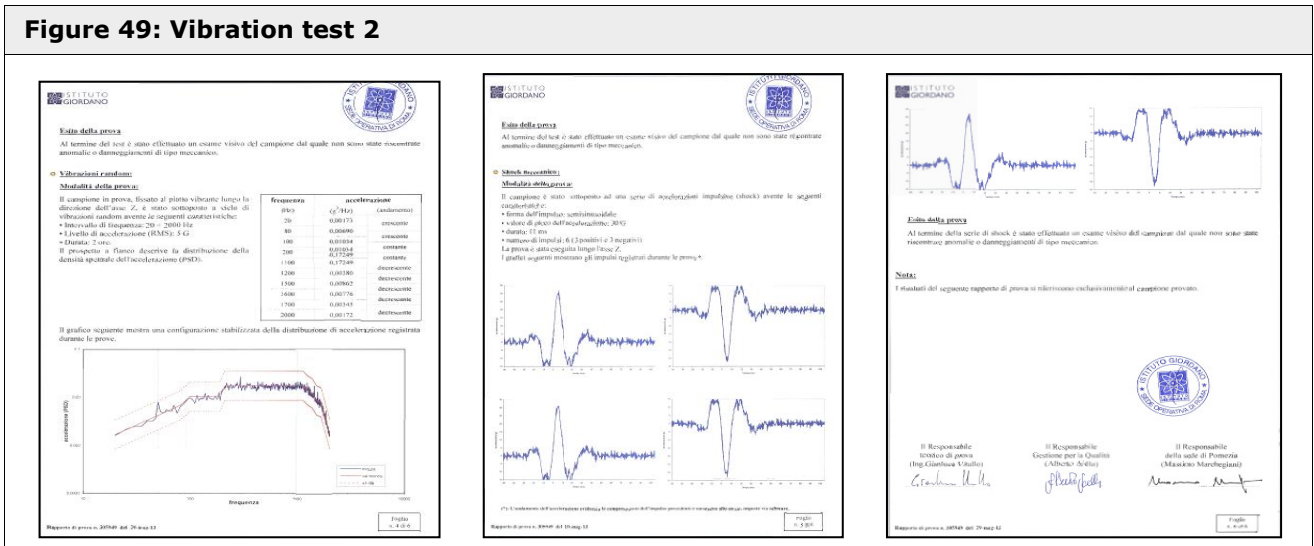

Figure 49: Vibration test 2



9.3 Lifetime calculation

Lifetime of power modules is limited by mechanical stress that occurs among the different materials of the package during operation. These mechanical stress is due to the different CTEs (coefficients of thermal expansion) of such materials.

A cross section of SKiM® module and the corresponding CTE values are shown in Figure 50 and Table 20.

Figure 50: SKiM®4 layer cross section

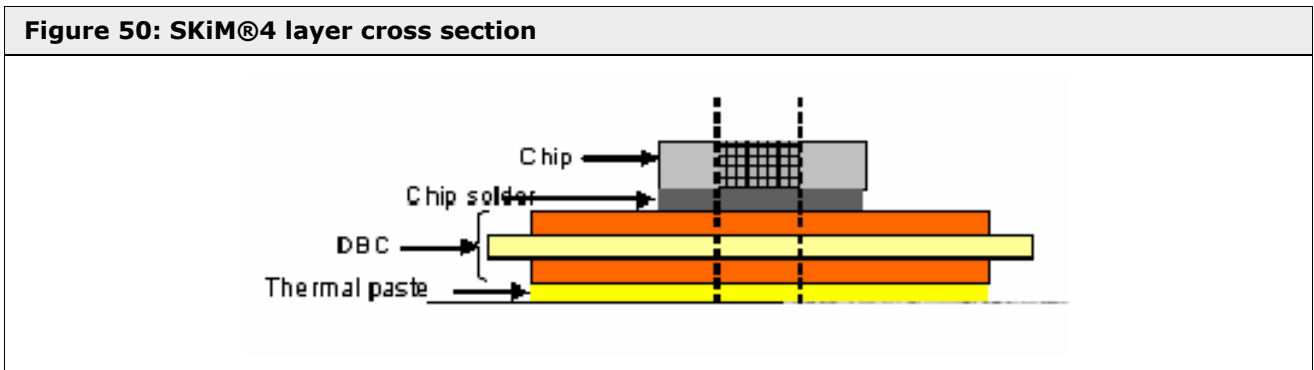
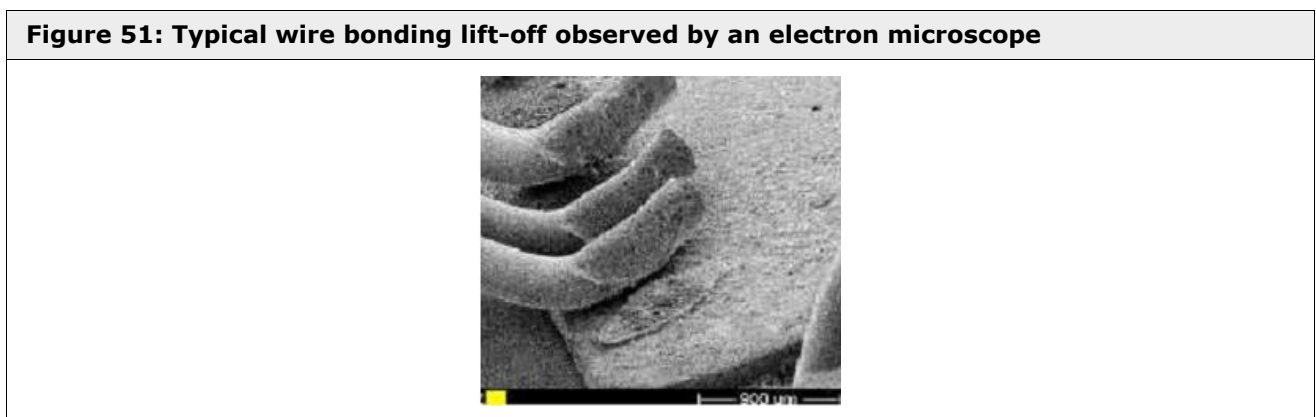

Table 20: CTE values for different materials		
Material	Thickness [mm]	CTE [10E-6/°C]
Chip	0.120	3.2
Chip solder	~0.1	28
DBC (copper)	0.4	16.7
DBC (Al ₂ O ₃)	0.5	6.7
DBC (copper)	0.4	16.7

During heating up and cooling down of a module the different materials expand according to their different CTE values; these materials are joined and therefore they don't expand freely and this leads to the above mentioned mechanical stress. Result is that after a certain number of power cycles the module fails. Typical example is the wire bond "lift off", that means contact between chip (or DBC copper) and wire bonds is lost (refer to the picture below):



Lifetime of a module is related to the temperature swing; that is the difference between the maximum temperature reached and the minimum temperature value.

Different investigations have been carried out in this area, including a research project known as "LESIT study". This study puts in evidence the relationship between the number of cycles, the junction temperature difference and the medium temperature.

$$N_f = A \cdot \Delta T_j^\alpha \cdot e^{\left(\frac{E_a}{k_B \cdot T_m}\right)}$$

with: N_f = number of power cycles
 k_B = Boltzmann-constant ($1.380 \cdot 10^{-23} \text{J/K}$)
 E_a = activation energy ($9.891 \cdot 10^{-20} \text{J}$)
 A = constant ($648000 \text{K}^{-\alpha}$)
 α = constant (-5.039)
 T_{jm} = medium junction temperature [K]

The curves for lifetime prediction for industrial standard of SKIM@4&5 are shown in Figure 52.

Figure 52: Power cycling value N_f as a function of the temperature cycling amplitude ΔT_j

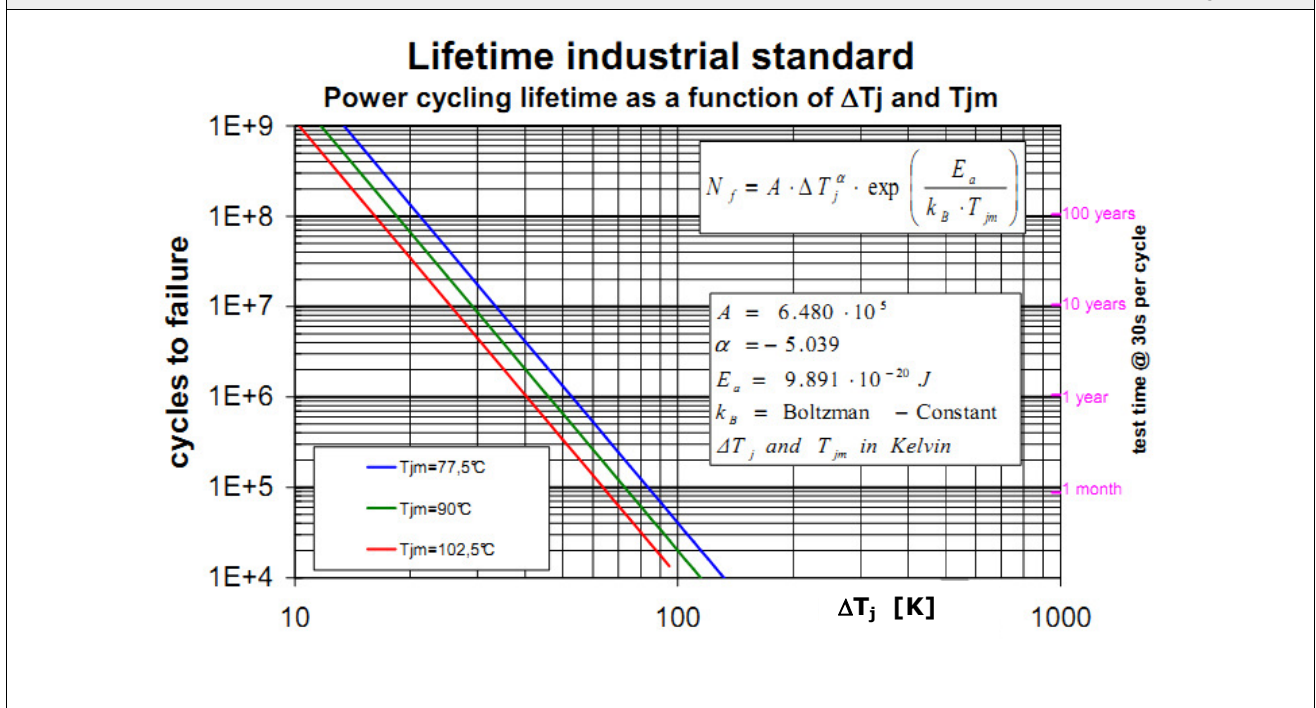

10. Marking

10.1 Laser marking of modules

All SKiM® modules are laser marked. The marking contains the following items (see Figure 53).

Figure 53: Typical laser marking of SKiM®4

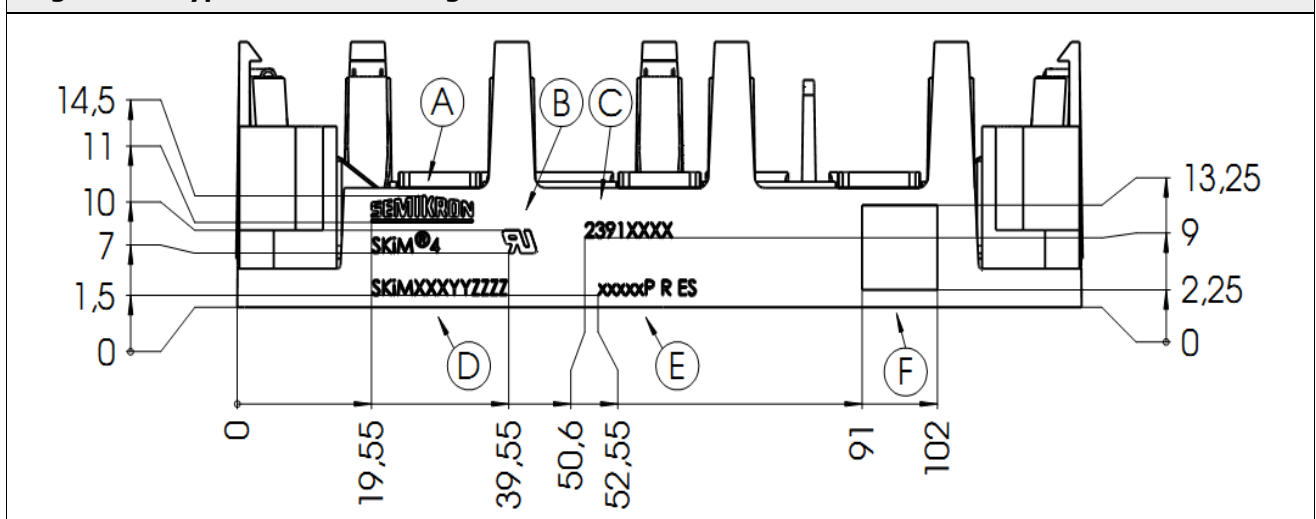

10.2 Laser marking for modules

- A. SEMIKRON & SKiM®4 logo (including trademark symbol);
- B. UL logo;
- C. Part number (commercial code);
- D. Module name
- E. Data Code (5 characters + additional letters):

- xx: year;
- xx: week;
- xx: production batch;
- P: production location (Pomezia);
- R: compliant to RoHs;
- ES: Samples (for the type of sample please refer to the documents attached to the shipment)

F. Data Matrix Code

- Dimension: 11x11mm;
- Field Size: 26x26 points;
- Data Coded: 53 alphanumeric digits:

SKiM®601TMLI12E4B 23918940XX 10IT35001059 1 1 0001 10020

①
②
③
④
⑤
⑥
⑦

1. Module name;
2. Part Number;
3. Production unique batch number;
4. Number of test line;
5. Number of production line;
6. Progressive number;
7. Data code;

11. Bill of Material

Figure 54: Sketch of SKiM®4 to illustrate the parts used

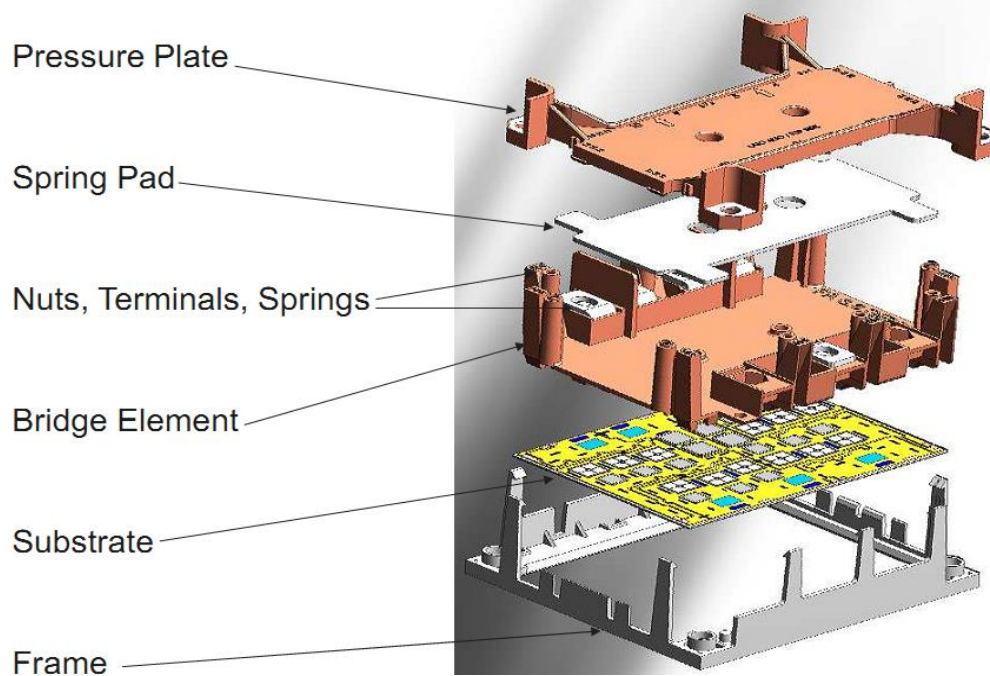

Table 21: SKiM®4 – bill of material	
Assembling material	
Housing	Makrolon 9425, white 09027
Pressure element	TAROMID 280H G6 DX0 TR1
Terminal	Gal. Ag 2-7µm
Contact spring	CuSn6 F95-DIN17682 – Ag 3-5µm
Spring pad	Silicone rubberHT800
Pressure plate	Ultramid A3X2G7
Nuts	M6 DIN 934-8
Power hybrids	
Substrate	Copper, aluminium oxide (Al ₂ O ₃), Copper
Wire bonds	Aluminium
Chips and T-sensor	Silicon (Si) with aluminium metallization on upper side and silver metallization on under side
Soldering powder	SN/AG96.5/3.5
Coating	Silicone gel

Note: SEMIKRON products are not subject to the electrical and electronic equipment law (ElektroG). Nevertheless, SEMIKRON still produces the product family SKiM® in accordance with §5 of the ElektroG (prohibited substances) as well as article 4 of the directive 2002/95/EC of the European parliament (RoHS) on the restriction of the use of certain hazardous substances in electrical and electronic equipment. The ElektroG is the German legal equivalent of the European directive.

12. Packaging Specifications

12.1 ESD cover

Against electrostatic discharge (ESD) during transport, the SKiM®4 is protected by an ESD cover. The ESD cover is shown in Figure 55.



ESD cover can be easily removed according to the following instructions:

- Start to release ESD cover from clips along one of the long sides
- Then release ESD cover from clips on the two shorts sides
- Finally the ESD cover can be removed by sliding it out of the other clips on the long side

Clips have to be removed one by one.

12.2 Packaging boxes

Figure 56: Card board with SKiM®4 in transparent ESD tray



Modules per package:	1		
Weight per package:	414g		
Bill of material:	Boxes:	Paper (card board)	
	Trays:	AS KPET/56 (not electrically chargeable)	

12.3 Marks of packaging boxes

All SKiM®4 packing boxes contain a label. This label is placed on the packing box as shown in Figure 57.

Figure 57: Location of labels on SKiM®4 packaging box



The label contains the following items (Figure 58).



- | | |
|--|--|
| <ol style="list-style-type: none"> 1. SEMIKRON Logo 2. "Dat. Cd:" 3. "Menge:" 4. Type Designation 5. "Au.-Nr:" 6. "Id.-Nr:" 7. Bar code | <p>Date code – 5 digits + additional letters:</p> <ul style="list-style-type: none"> • YY (year) WW (week) L (L = Lot of same type per week) • Suffix "P" indicates production location (Pomezia) • Suffix "R" stands for RoHS compliance <p>Quantity per box – also as bar code</p> <p>Lot number</p> <p>SEMIKRON part number – also as bar code</p> <p>bar code with 12 digits that should identify univocally every SEMIBOX:</p> <ul style="list-style-type: none"> • 2 digits to identify SKHC origin (IT for Italy) • 1 digit to identify the department originating the SEMIBOX • 2 digits for the year • 2 digits for the week • 5 digits sequential number |
|--|--|

SKiM® IGBT modules are sensitive to electrostatic discharges. Always ensure the environment is ESD proof before removing the ESD packaging and handling the modules.

13. Environmental conditions

13.1 Climatic conditions, air humidity limits

Climatic conditions include air temperature, absolute and relative air humidity, condensation rate of temperature change, barometric pressure, solar and thermal radiation, air movement, wind driven rain, water (except for rainfall) and ice formation.

Climatic conditions are classified into 11 categories designated by codes 3K1 ...3K11, which are sorted in ascending order with reference to their degree of climatic impact. The most important climatic classes are summarized in [2] chapter 6.2.1.

Most of SEMIKRON power modules, including SKiM@4&5, conform to climate class 3K3 as per EN 60721-3-3 in compliance with the EN 50178 and, with regard to clearance and creepage distances, may be operated under pollution degree 2 conditions stipulated by EN 50178 and EN 61800-5-1

We remind the 3K3 climate classes as defined : Closed locations, with air temperature regulation, non-regulated air humidity, condensation ruled out.

Silicone-based single-layer coating and encapsulation system provide protection against humidity level but does not provide a sealed barrier. The speed of diffusion of water ions in the silicone gel is not zero and depend by the environmental condition. For instance amounts to 0.04 mm/s at 18°C, increasing up to 1 mm/s at 100°C. For silicon layers of approx.. 5 mm in thickness, the saturation state is reached within 5 hours.

Accordingly, operation is not permitted in places of operation or installation where dripping or condensation water impacts on the power modules for example. Condensation is admissible occasionally only, and on provision that the system is not under voltage. Under no circumstances may condensation residue resulting from occasional condensation be allowed to accumulate due to frequent condensation/drying cycles.

To prevent power semiconductors failure due to condensation, applications must comply with the component-specific climatic requirements. For operation, additional anti-condensation measures such as standstill heating, air conditioning, continuous duty, cooling water temperature etc. must be taken.

According to climate class 3K3, operation must take in place in shielded locations which must not be exposed to weather and which have a maximum relative humidity of 85% and absolute air humidity of 26 g/m³ . At 40°C, for example, the relative air humidity must not exceed 50%. Further details can be founded in [2].

Please contact your local Semikron representative to get support in case you have further questions on this topic.

Figure 1: SKiM®4 (footprint = 106,5 x 123mm ²)	2
Figure 2: Electrical configuration of SKiM®4 MLI (left) and TMLI (right).....	3
Figure 3: Cross-sectional drawing of SKiM®4	4
Figure 4: Construction principle of SKiM®4	4
Figure 5: Bridge element with pressure points and substrate with contact points	5
Figure 6: SKiM®4 mechanical layout.....	5
Figure 7: SKiM®4 MLI conduction paths for positive (left) and negative (right) output current	7
Figure 8: MLI commutation loops and inductances test set up	8
Figure 9: SKiM®4 TMLI conduction paths for positive (left) and negative (right) output current.....	9
Figure 10: SKiM®4 TMLI commutation loops and inductances test set up	9
Figure 11: TNPC: IGBT1 & Diode2 turn-on / -off energy	12
Figure 12: TNPC: IGBT2 & Diode1 turn-on / -off energy	12
Figure 13: NPC: IGBT1 & Diode5 turn-on / -off energy	13
Figure 14: NPC: IGBT2 & Diode1 turn-on / -off energy	13
Figure 15: Creepage path from main terminal to main terminal (left) and clearance from main terminal to ground (right)	14
Figure 16: SKiM®4 MLI chip positions	17
Figure 17: SKiM®4 TMLI chip positions	20
Figure 18: SKiM®4 sketch – cross section view	21
Figure 19: IGBT concepts, basic properties	21
Figure 20: Punch-Through IGBT with planar gate (left), Non-Punch-Trough IGBT with planar gate (right) ..	22
Figure 21: SOA IGBT	23
Figure 22: RBSOA IGBT	23
Figure 23: SCSOA 1200V IGBT (left) and 650V IGBT (right).....	24
Figure 24: Location of reference point for R _{th} measurement as used for SKiM®	25
Figure 25: Standardized transient thermal impedance of SKiM®4 MLI and SKiM®4 TMLI.....	26
Figure 26: Typical characteristic of the SKiM®4 NTC temperature sensor	27
Figure 27: SKiM®4 NTC temperature sensor position	28
Figure 28: Sketch of high energy plasma caused by bond wire melting.....	29
Figure 29: Heatsink surface specifications.....	29
Figure 30: SKiM® bottom surface discoloration	30
Figure 31: SKiM® bottom surface after rework.....	30
Figure 32: Scratches on the SKiM® surface	31
Figure 33: Etching hole (hole down to substrate level) in the SKiM® bottom surface.....	31
Figure 34: Etching hole (hole NOT down to substrate level) in the SKiM® bottom surface.....	31
Figure 35: SKiM®4 with pre-applied thermal paste	32
Figure 36: Example for mounting sequence of SKiM®4	33
Figure 37: Example for mounting sequence of SKiM®5	33
Figure 38: Terminal pulling forces.....	35
Figure 39: Recommended DC bus-bar assembly scheme	36
Figure 40: Landing pads layout for SKiM®4	37
Figure 41: PCB assembly on the SKiM®4.....	37
Figure 42: SKiM®4 driver application boards.....	38
Figure 43: Guiding pin for SKiM®4	39
Figure 44: Guiding pin positions of SKiM®4	39
Figure 45: Final assembly of driver PCB.....	40
Figure 46: Salt fog test.....	43
Figure 47: Harmful gases test	43
Figure 48: Vibration test 1	44
Figure 49: Vibration test 2	44
Figure 50: SKiM®4 layer cross section	44
Figure 51: Typical wire bonding lift-off observed by an electron microscope	45
Figure 52: Power cycling value N _f as a function of the temperature cycling amplitude ΔT _j	46
Figure 53: Typical laser marking of SKiM®4.....	46
Figure 54: Sketch of SKiM®4 to illustrate the parts used	47
Figure 55: SKiM®4 with transparent ESD cover.....	48
Figure 56: Card board with SKiM®4 in transparent ESD tray.....	49
Figure 57: Location of labels on SKiM®4 packaging box	49
Figure 58: Declaration of the label	50
Table 1: Commutation inductances of SKiM®4&5 TMLI / MLI	11
Table 2: Creepage and clearance distances for SKiM®	14



Table 3: SKiM®4 MLI product portfolio and chipset	16
Table 4: SKiM®4 TMLI product portfolio and chipset	16
Table 5: Chip positions and dimensions of SKiM®4 MLI with minimum amount and size of chips	18
Table 6: Chip positions and dimensions of SKiM®4 TMLI with minimum amount and size of chips.....	19
Table 7: Material data for thermal simulations.....	20
Table 8: Coefficients for calculating $Z_{th(j-s)}$ of SKiM®4 MLI and SKiM®4 TMLI	26
Table 9: NTC resistance values.....	28
Table 10: Torque specification for heatsink fixing.....	33
Table 11: Disassembling process for SKiM® modules	34
Table 12: Torque specification for terminal mounting	35
Table 13: Maximum pulling forces per terminal	35
Table 14: Torque specification for PCB mounting	38
Table 15: Specification for SKiM® contact springs	40
Table 16: Specifications for the surface metallization of SKiM® contact spring landing pads.....	40
Table 17: Storage conditions.....	41
Table 18: Shelf life conditions (¹).....	41
Table 19: SEMIKRON standard qualification tests.....	42
Table 20: CTE values for different materials	45
Table 21: SKiM®4 – bill of material	48



Symbols and Terms

Letter Symbol	Term

A detailed explanation of the terms and symbols can be found in the "Application Manual Power Semiconductors" [2]

References

- [1] www.SEMIKRON.com
- [2] A. Wintrich, U. Nicolai, W. Tursky, T. Reimann, "Application Manual Power Semiconductors", ISLE Verlag 2015, ISBN 978-3-938843-83-3
- [3] R. Annacker, R. Herzer, IGBT4 Technology Improves Application Performance, Bodo 's Power Systems, Issue June 2007
- [4] Wintrich, IGBT4 and Freewheeling Diode CAL4 in IGBT Modules, SEMIKRON Application Note, AN-7005, Nuremberg, 2008
- [5] V. Demuth et al., CAL 4: The Next-Generation 1200V Freewheeling Diode, Proceedings PCIM China, 2007
- [6] I. Rabl, Application Note AN-11001: 3L NPC-NPC Topology.

HISTORY

SEMIKRON reserves the right to make changes without further notice herein

DISCLAIMER

The data given in this document shall be for information purposes only. It may not reflect the product in its latest status. For a valid product specification please refer to the relevant product data sheet in the actual version.

All information herein is confidential and provided as a service to customers of SEMIKRON. SEMIKRON reserves the right to make changes without further notice herein to improve reliability, function or design. Information furnished in this document is believed to be accurate and reliable. However, no representation or warranty is given and no liability is assumed with respect to the accuracy or use of such information. SEMIKRON does not assume any liability arising out of the application or use of any product or circuit described herein. Furthermore, this information may not be considered as an assurance of component characteristics. No warranty or guarantee expressed or implied is made regarding delivery, performance or suitability. This document is not exhaustive and it supersedes and replaces all information previously supplied and may be superseded by updates without further notice.

Test data here presented are Intellectual Property of Semikron, as such cannot be disclosed to any third parties. SEMIKRON shall accept no liability for the relevance, accuracy or completeness of the information contained therein. SEMIKRON accepts no liability nor provides any guarantee as to the usability of the information conveyed or contained in this report. Prior to using this report, the customer is responsible for ascertaining that the information contained therein is suitable or fit for the designated purpose. The information and values given by this report represents only the characteristics of the measured/analyzed products/items.

SK assumes no liability for applications assistance or customer product design. Customers are responsible for their products and applications using SK components. To minimize the risks with customer products and applications, customers should provide adequate design and operating safeguards.

SEMIKRON products are not authorized for use in life support appliances and systems without the express written approval by SEMIKRON.

SEMIKRON INTERNATIONAL GmbH
P.O. Box 820251 • 90253 Nuremberg • Germany
Tel: +49 911-65 59-234 • Fax: +49 911-65 59-262
sales.skd@semikron.com • www.semikron.com