

# Technical Explanations

## SKiM<sup>®</sup>63/93

### IGBT Modules

Revision:	1.53
Issue date:	2018-09-21
Prepared by:	Anastasia Schiller
Approved by:	Rainer Weiss

Keyword: IGBT module, automotive

**Please note:**

Unless otherwise specified, all values in this technical explanation are typical values. Typical values are average values derived from large quantities of tested SKiM modules and are provided for information purposes only, thus, they're not a binding specification. These values can and do vary under different application conditions. All operating parameters must be validated by the user's technical experts for each application.

This document is valid for the following SKiM<sup>®</sup>63/93 part numbers:

Part number	Type SKiM63 sinter	Part number	Type SKiM93 sinter
23630030	SKiM406GD066HD	23930010	SKiM459GD12E4
23630040	SKiM606GD066HD	23930120	SKiM459GD12E4V2
23630050	SKiM306GD12E4	23930170	SKiM459GD12F4V4
		23930190	SKiM459GD12F4V3
		23930300	SKiM429GD17E44F
		23930780	SKiM609GAL12E4
		23930790	SKiM909GD066HD
		23930820	SKiM609GAR12E4
		23930840	SKiM429GD17E4HD
		23930210	SKiM909GD066HDV2

This technical explanation document is valid as well for soldered type of SKiM<sup>®</sup>63/93 with part numbers mentioned below excepting the features which are subject of a sinter process specification, especially reliability characteristic, see Chapter 7.

Part number	Type SKiM63 solder	Part number	Type SKiM93 solder
23630240	SKiM606GD07V1	23930310	SKiM909GD07V1

The document remains effective until replaced by a subsequent revision of this document.

# Table of Contents

1. Introduction.....	4
1.1 Features .....	4
1.2 Advantages and Benefits .....	4
2. Technical Details of SKiM.....	4
2.1 Mechanical Design .....	4
2.2 Electrical Behavior .....	6
2.3 Comparison between sintered and soldered modules .....	8
2.4 Protected Springs .....	9
2.5 Creepage and Clearance Distances .....	9
2.6 Isolation Measurement.....	10
2.7 Chip Positions .....	11
2.8 Thermal Material Data .....	12
2.9 Pressure Force on the Heat Sink.....	13
3. Chip Technologies and Product Ranges.....	14
3.1 IGBT Chip Technologies and Product Range .....	14
3.2 Safe Operating Area for IGBTs .....	15
3.3 Surge Current Characteristics of CAL Diodes.....	18
3.4 Selection Guide.....	18
4. Thermal Resistances .....	19
4.1 Measuring Thermal Resistance $R_{th(j-s)}$ .....	19
4.2 Transient Thermal Impedance.....	20
5. Integrated Temperature Sensor Specifications .....	21
5.1 Electrical Characteristic for PTC temperature sensor .....	21
5.2 Electrical Characteristic NTC temperature sensor.....	22
5.3 Electrical Isolation .....	24
6. Spring Contact System Specifications.....	25
6.1 Spring and Contact Specifications.....	25
6.2 PCB Specifications (Landing Pads for Springs).....	25
6.3 Storage Conditions .....	25
6.4 Stray Inductance of Contact Springs.....	25
6.4.1 Self-Inductance of the Spring Connection.....	26
7. Reliability .....	27
7.1 Standard Tests for the Qualification of SKiM Modules .....	27
7.2 Reliability of Spring Contacts .....	28
7.3 Reliability of SKiNTER Layer.....	29
8. Design Recommendations for SKiM.....	31
8.1 Printed Circuit Board Design .....	31
8.1.1 PCB Specification .....	31
8.1.2 PCB Alignment Support.....	31
8.1.3 PCB Outline, Location of Landing Pads .....	32
8.1.4 General Design Rules.....	33
8.1.5 Gate Clamping .....	33
8.1.6 Connection of Unused Springs for GAL and GAR Types.....	34
8.2 Paralleling SKiM IGBT Modules .....	34
8.2.1 Paralleling of Gate and Emitter Connections .....	34
8.2.2 Main Terminal Paralleling .....	35
8.3 DC Link Bus Bars, Snubber Capacitors .....	36
9. Marking.....	38
9.1 "Passed" marking on housing.....	38
9.2 Laser Marking for Modules.....	38
9.3 Data Matrix Code .....	39
10. Bill of Materials .....	40



11. Packing Specifications .....	41
11.1 ESD COVER .....	41
11.2 Packing Boxes.....	41
11.3 Marking of Packing Boxes .....	42
12. Type Designation System .....	44
13. Figure Captions in the Datasheets .....	45
14. Disclaimer .....	46



## 1. Introduction

SKiM is an established SEMIKRON's product line for highly reliable IGBT modules made specifically for automotive applications. SKiM is available in two package sizes: SKiM 63 and SKiM 93 (Fig. 1-2) and two versions: soldered and sintered (see the part numbers on the first page).

### 1.1 Features

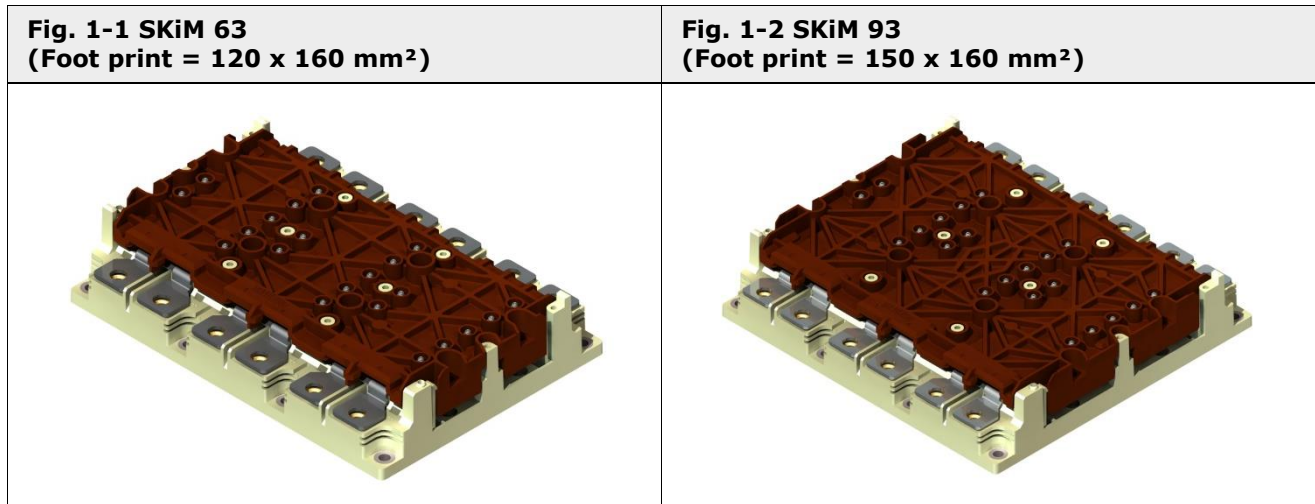

SKiM modules feature a pressure-contact low-profile housing that boasts the following advantages:

- Pb-free module
- Sinter version SKiM63/93 is a 100 % solder-free module
- Solder-free driver assembly with no additional wiring or connectors
- Spring contacts for auxiliary contacts
- Separate AC, DC terminals and control unit
- 17 mm main terminal height

### 1.2 Advantages and Benefits

The above-mentioned features allow for a compact, flat and low-inductance inverter design. Direct driver assembly provides optimum IGBT controllability and eliminates noise on gate wires or loose connectors. For further information on SKiM please refer to:

- P. Beckedahl, T. Grasshoff und M. Lederer; *A new power module concept for automotive applications*; PCIM Nuremberg; May 2007

## 2. Technical Details of SKiM

### 2.1 Mechanical Design

SKiM (Fig. 2-1) is based on the well-established SKiiP technology. This means the Al<sub>2</sub>O<sub>3</sub> DBC (direct bonded copper) substrate is pressed directly onto the heat sink without the use of a base plate.

**Fig. 2-1 Cross-sectional picture of SKiM 63**

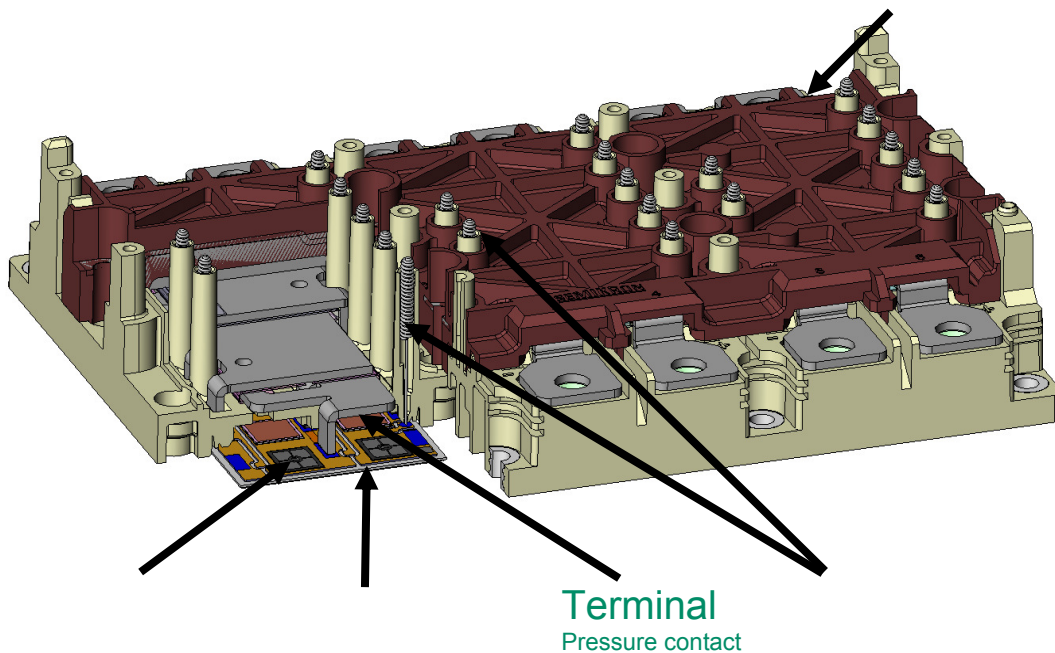

The pressure is induced by a pressure part on top, which is screwed to the heat sink. This pressure is transferred to the three main terminals (plus, minus and AC), as shown in **Fig. 2-2**. These main terminals constitute a low-inductance sandwich construction and transfer the pressure to the above-mentioned DBC substrate. The pressure is applied across several contact points (cf. **Fig. 2-3**) beside every single chip. As a result, a very low thermal and ohmic resistance  $R_{CC'+EE'}$  is achieved.

**Fig. 2-2 "Sandwich" of main terminals (SKiM 63)**

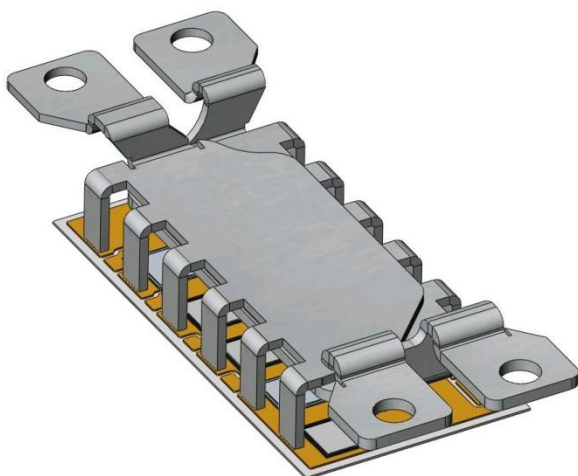

**Fig. 2-3 DBC substrate with pressure points (SKiM 63)**

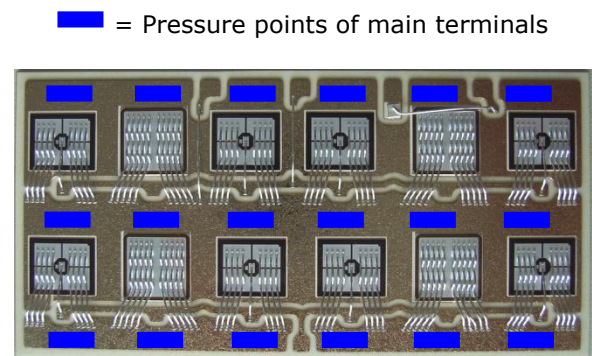

The chips themselves are sintered or soldered. The sintering is based on pulverised silver which forms a material connection when pressure and temperature is applied. (cf. section 2.3)

Contact springs are used for all of the auxiliary contacts (gate, auxiliary emitter and collector, temperature sensor). These spring contacts allow for solder-free connection of the driver PCB.

## 2.2 Electrical Behavior

In a high-power module with paralleled chips, the switching behaviour and the resulting derating is important.

### Current Distribution

The current distribution between silicon chips is affected mainly by the parasitic stray inductances and the difference in these inductances between the chips. Two design features influence these parasitic stray inductances: first the layout of the chips on the substrate and hence the commutation behaviour between IGBT and diode; second the internal design of the main terminals.

#### Influence of the chip distribution on the DBC

If the DBC layout is not symmetric (e.g. as shown in Fig. 2-4) the commutation paths of the different currents have different parasitic inductances, leading to different currents, losses and, ultimately, temperatures in the different chips (cf. Fig. 2-5). To prevent individual chips from overheating, derating is necessary.

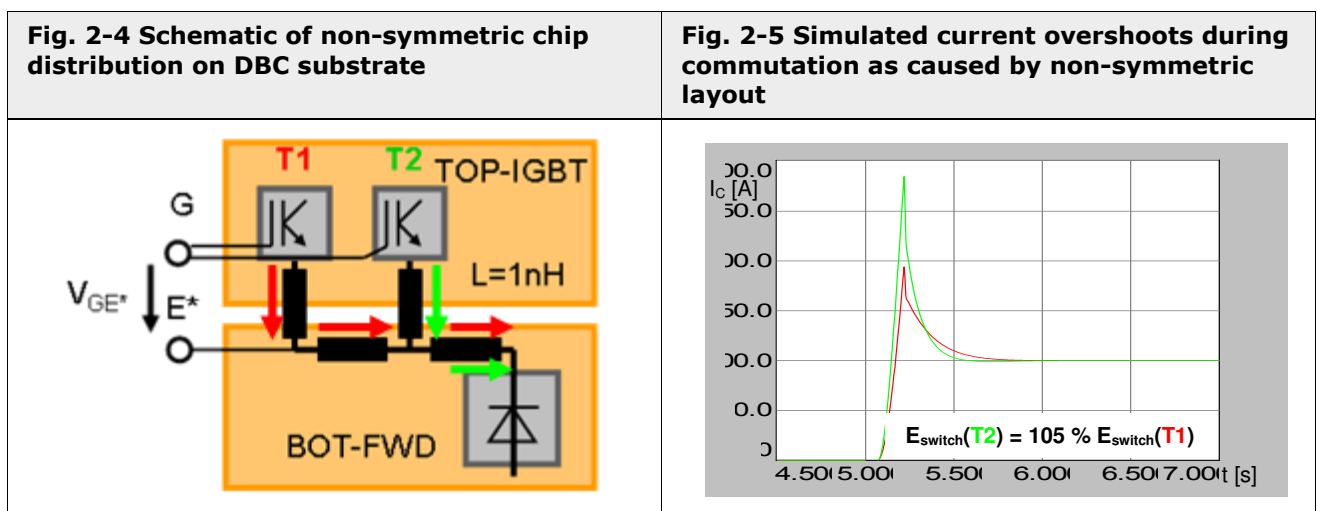

The SKiM DBC layout (Fig. 2-3) is largely symmetric and has symmetric inductances in the current paths (Fig. 2-6). The commutation behaviour across all chips is therefore very even (Fig. 2-7) and derating is not necessary.

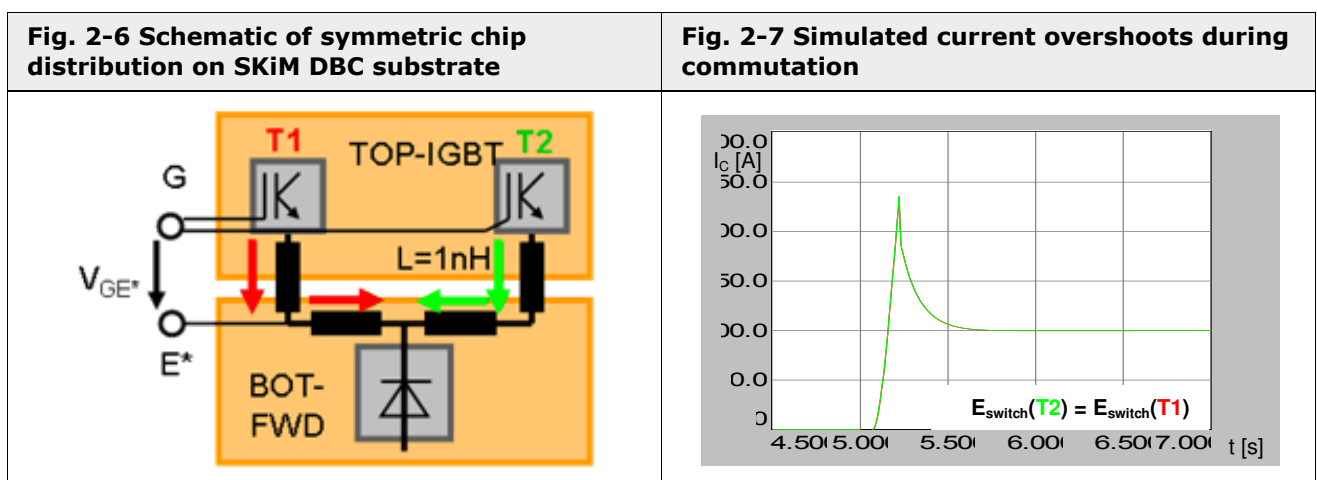

*Influence of the internal main terminal design*

The bus bar system in SKiM modules, as shown in Fig. 2-2, has a very low stray inductance ( $L_{CE} < 10 \text{ nH}$ ). Every single chip is connected symmetrically (cf. Fig. 2-3). This leads to similar stray inductances for the individual chips, resulting in a homogeneous current distribution.

Measurements have verified a homogenous internal current distribution. The voltage drop across a single chip is an indicator for the current through this chip. The measured voltage drops at three different chip positions on the substrate, as well as at the position of the auxiliary emitter are nearly identical, indicating a very homogenous current distribution.

There is a difference between the internal voltages and the current at the outer +/- terminals, resulting from the voltage drop between the chips positions and the main terminals.

*Comparison: Top versus Bottom IGBT*

Besides even current distribution between paralleled chips, the symmetry in switching between top and bottom IGBT in a half bridge configuration is also important in terms of derating. This means if the two IGBTs switch differently, the IGBT with higher losses will limit the module as a whole.

Thanks to the symmetric DBC layout in SKiM modules (cf. Fig. 2-3, Fig. 2-8 and Fig. 2-10), the switching behaviour of the bottom and the top IGBT is virtually identical, as shown in Fig. 2-9 and Fig. 2-11. Derating is therefore not necessary.

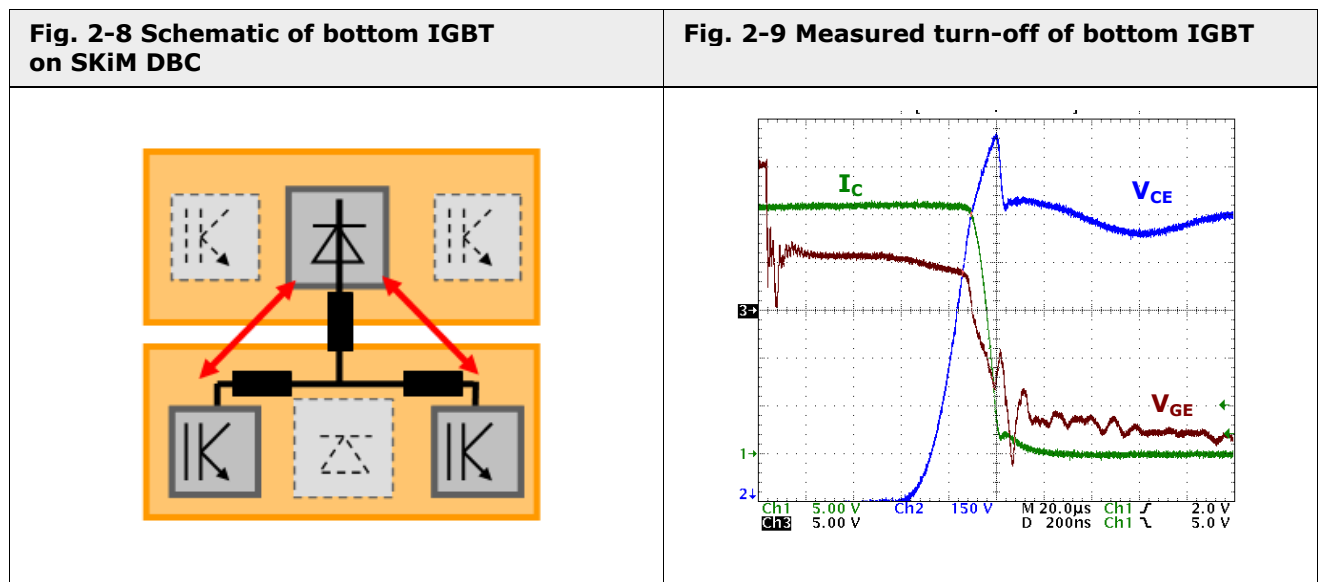

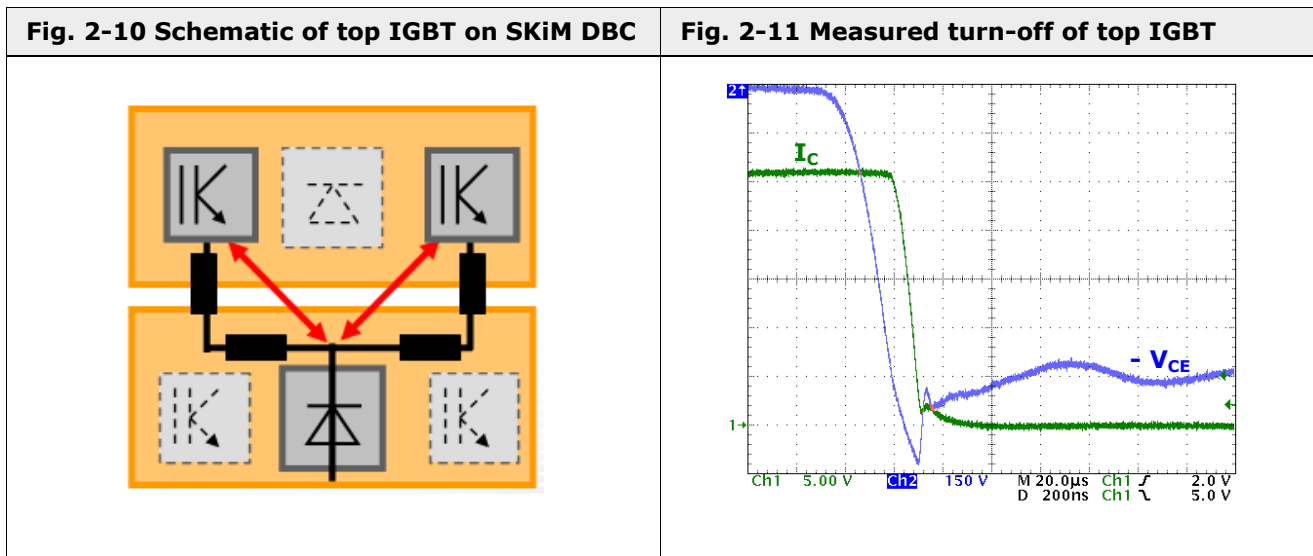

For further information on optimisations in SKiM processes, please refer to:  
A.Wintrich, P. Beckedahl, T.Wurm ; "Electrical and thermal optimization of an automotive power module family"; Proceedings Automotive Power Electronics; Paris; October 2007

### 2.3 Comparison between sintered and soldered modules

For the SKiM product line SEMIKRON improved the sintering process for silver powder to enable it to be used in series production. This "SKiNTER" process replaces chip soldering and results in very high degree of joint reliability.

The SKiNTER process works as follows: the silver powder is printed to the DBC substrate. Then the chips are placed onto this silver layer. The joint is created by applying heat (< 250°C) and pressure. Though the SKiNTER process temperature is far below the melting point of silver (960 °C), the final joint is stable up to this temperature.

The following table Tab. 2-1 shows a comparison between the SKiNTER process and soldering.

<b>Tab. 2-1 Comparison between sinter and solder versions SKiM63/93</b>		
	<b>SKiNTER process</b>	<b>Soldering</b>
Joining temperature	< 250°C	200 – 380°C
Layer thickness	15 – 20 µm	70 – 150 µm
Connection layer	homogeneous	inhomogeneous
Melting temperature	960 °C	< 380 °C
Thermal conductivity	240 W/(m·K)	70 W/(m·K)
Electrical conductivity	41 m/(Ω·mm <sup>2</sup> )	8 m/(Ω·mm <sup>2</sup> )
Coefficient of thermal expansion	19 ·10 <sup>-6</sup> m/K	28 ·10 <sup>-6</sup> m/K
Tensile strength	55 MPa	30 MPa

For further information on the SKiNTER process, please refer to:

- C. Göbl, P. Beckedahl, H. Braml ; "Low temperature sinter technology Die attachment for automotive power electronic applications"; Automotive Power Electronics; June 2006

## 2.4 Protected Springs

When the SKiM is not mounted to the heat sink and the pressure part is not pressed down, the springs for the auxiliary contacts are protected inside the module (Fig. 2-12). Fig. 2-13 shows a SKiM module after mounting. The pressure part is pressed down and the spring heads appear at the surface.

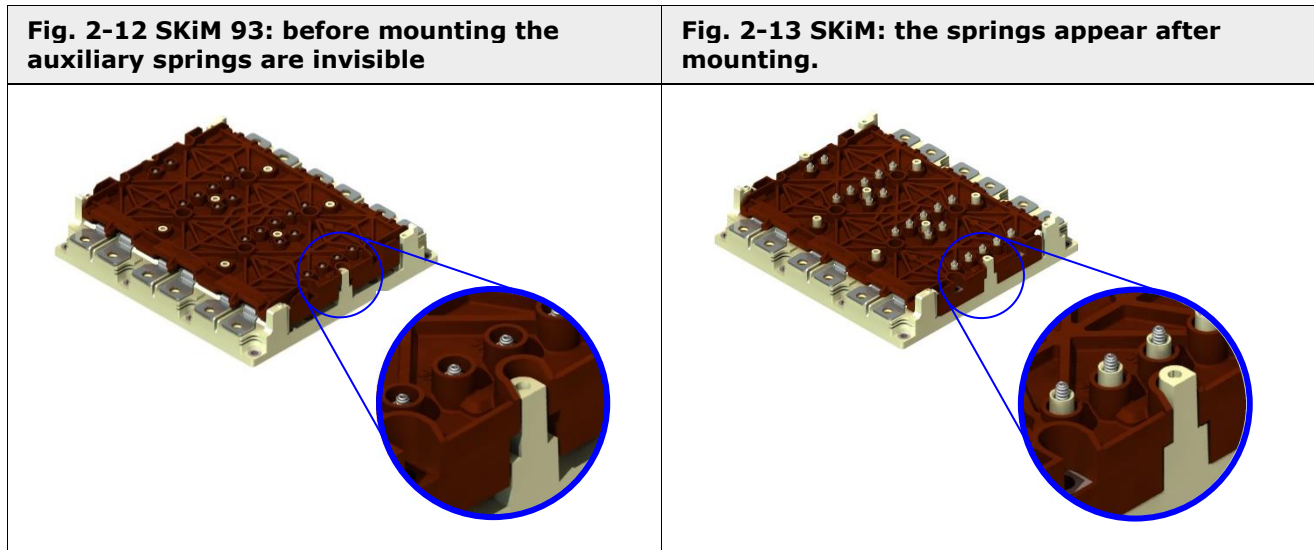

## 2.5 Creepage and Clearance Distances

All SKiM IGBT modules comply with the mandatory creepage and clearance distances in accordance with EN 61800-5-1 for

- Grid voltage = 690 V, line to line, grounded delta
- Transient voltage = 1700 V (DC link voltage = 1250 V)
- Basic isolation
- Pollution degree 2
- Comparative Tracking Index "CTI" value of the case < 400

The following values are complied with:

<b>Tab. 2-2 Creepage and clearance distances for SKiM</b>	
Creepage distance from main terminal to main terminal	≥ 14 mm
Clearance distance from main terminal to main terminal	≥ 5,8 mm
Creepage distance from any terminal to heat sink potential	≥ 8,3 mm
Clearance distance from any terminal to heat sink potential	≥ 8.0 mm
Creepage distance on the PCB from landing pad to landing pad	≥ 6.3 mm

- "From terminal to terminal" means for main and auxiliary terminals between high-voltage potentials, not between terminals with small differences in voltage potential, e.g. gate and emitter contacts ( $\pm 20$  V) or between the contacts for the temperature sensor.

In the case of "1700 V applications" SEMIKRON recommends the use of "low profile screws" with a maximum screw head height of 2.8 mm. For 1200 V all of the distances are met with standard screws (4 mm head height) as given in the mounting instructions.

The following sketches (Fig. 2-14 and Fig. 2-15) show the distances without screws.

Inside the housing, the DBC substrate is coated with a silicone gel for electrical isolation. The gel has an isolation capability > 20 kV/mm.

**Fig. 2-14 Clearance from main terminals to heat sink potential**

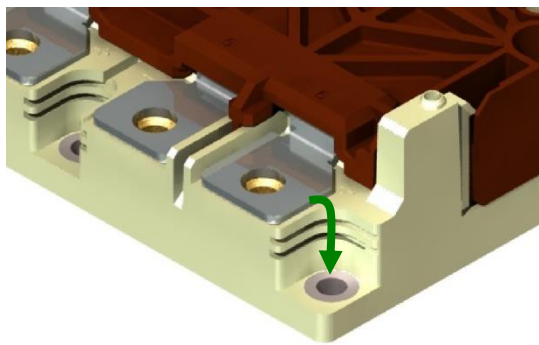

Clearance = 12 mm without screw

**Fig. 2-15 Clearance from PCB to heat sink potential**

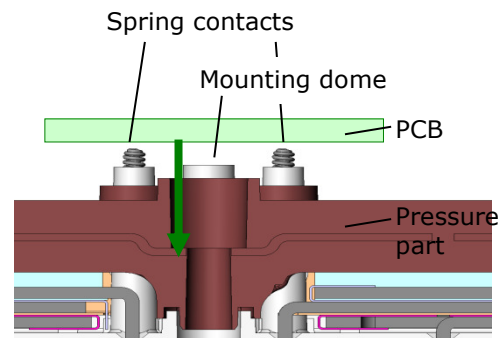

Clearance = 11.3 mm without screw

## 2.6 Isolation Measurement

The specified isolation voltage is given in the data sheets. In the course of production, this isolation voltage is verified with a 100% test according to the EN 61800-5-1 standard. The routine tests during production have a duration of 1 s.



The isolation measurement is performed in two steps:

During the first measurement all main and auxiliary terminals (including main, auxiliary emitter, gate and temperature sensor contacts) are short circuited and measured against the base plate.

In the second measurement stage the main and auxiliary terminals (including main, auxiliary emitter, gate contacts) are short circuited, as are the base plate and the temperature sensor contacts. The voltage  $V_{isol}$  is then applied between these two circuits.

## 2.7 Chip Positions

For detailed temperature measurements the exact positions of the chips have to be known. Inside SKiM modules, the chips are always located in the same positions, regardless of the chip size. The drawings Fig. 2-19 and Fig. 2-20 show the chip positions measured from the centre of the bottom left screw hole.

Fig. 2-16 IGBT Chips	Fig. 2-17 Diode Chip	Fig. 2-18 Temp. Sensor
		

**Fig. 2-19 Chip positions in SKiM 63**

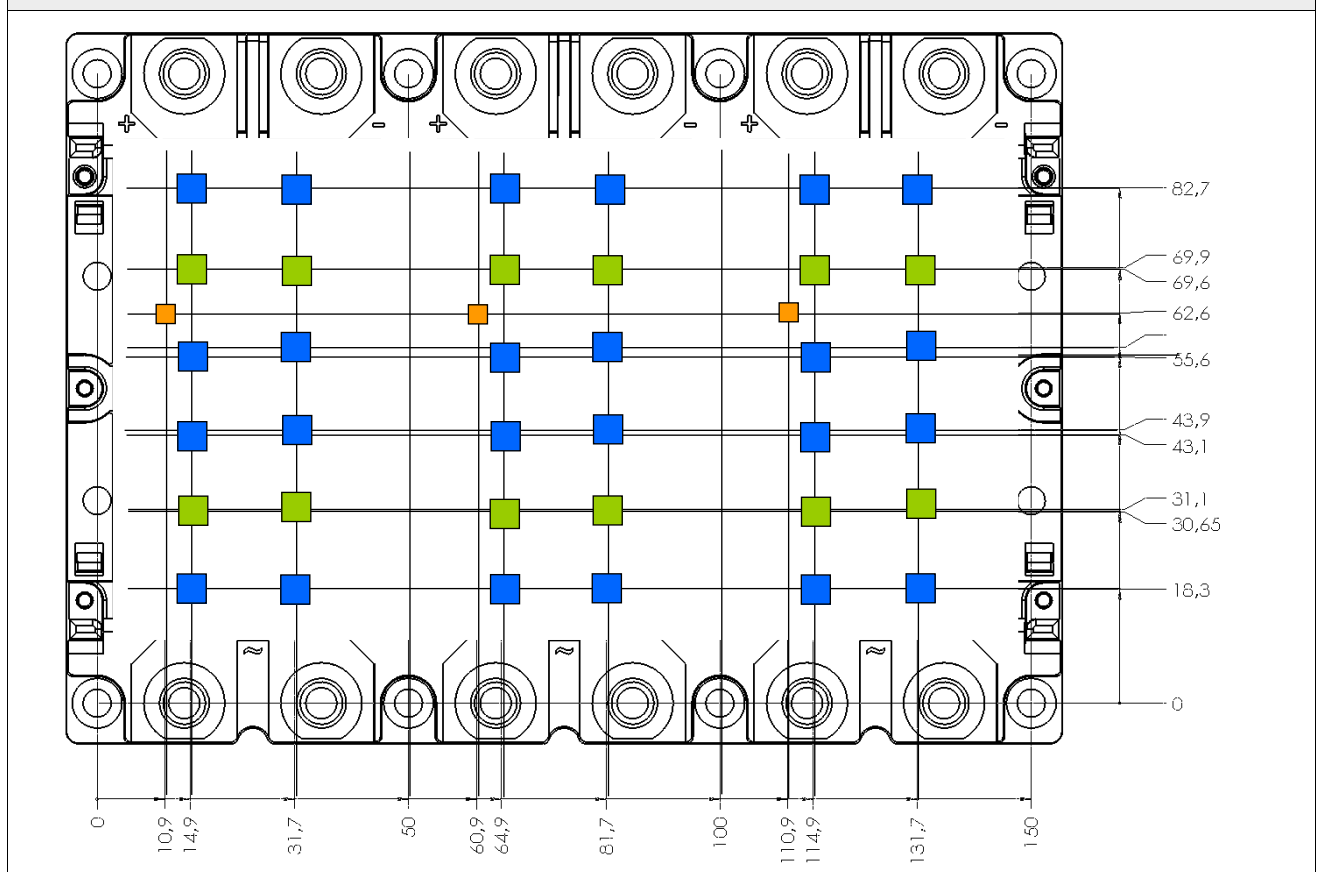

**Fig. 2-20 Chip positions in SKiM 93**

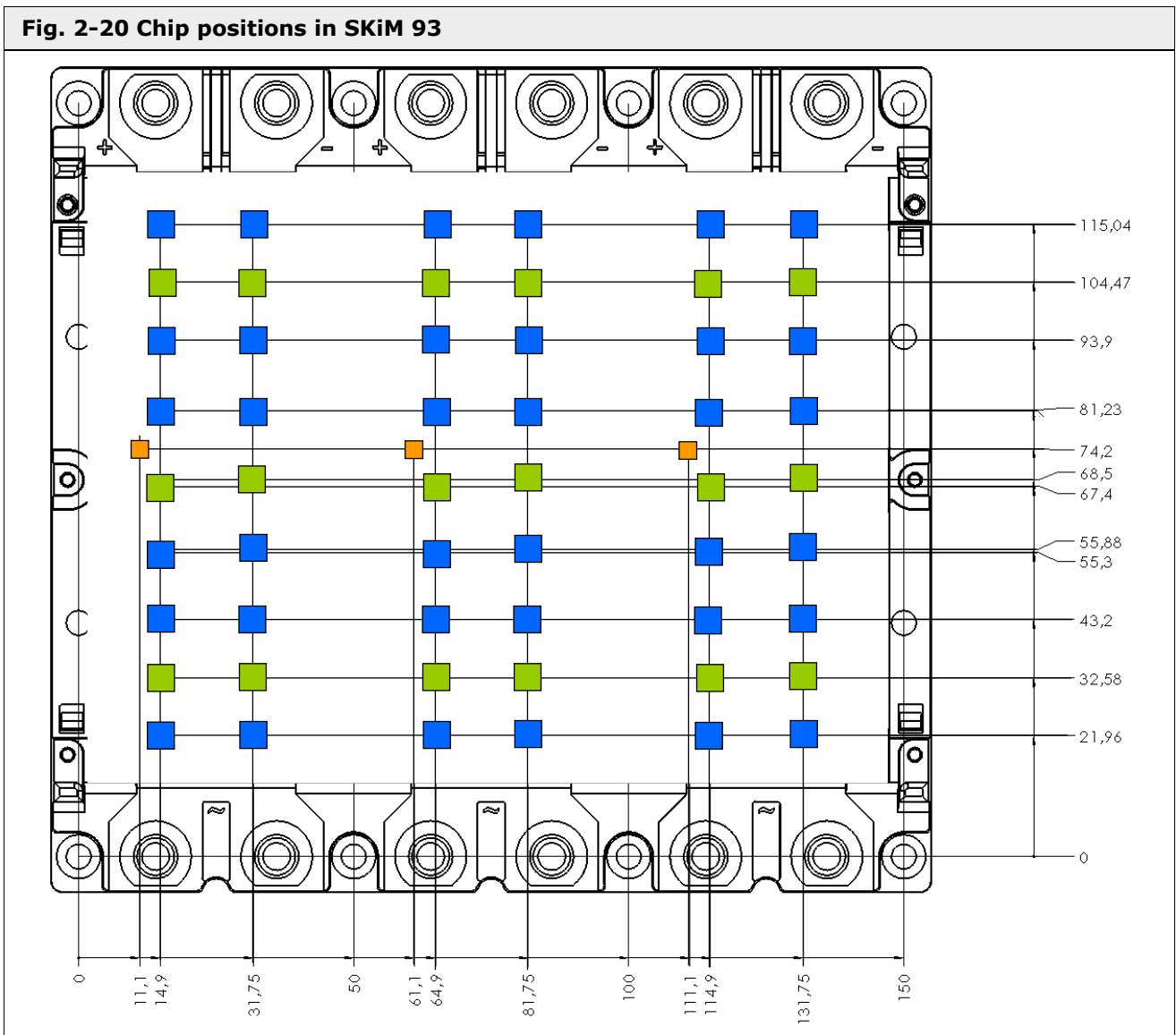

**2.8 Thermal Material Data**

For thermal simulations it is necessary to have the thermal material parameter, as well as the typical thickness of the different layers in the package. This data is given in Tab. 2-3. For better understanding, the sketch in Fig. 2-21 shows the different layers in the package.

**Fig. 2-21 Sketch of SKiM package, cross-sectional view**

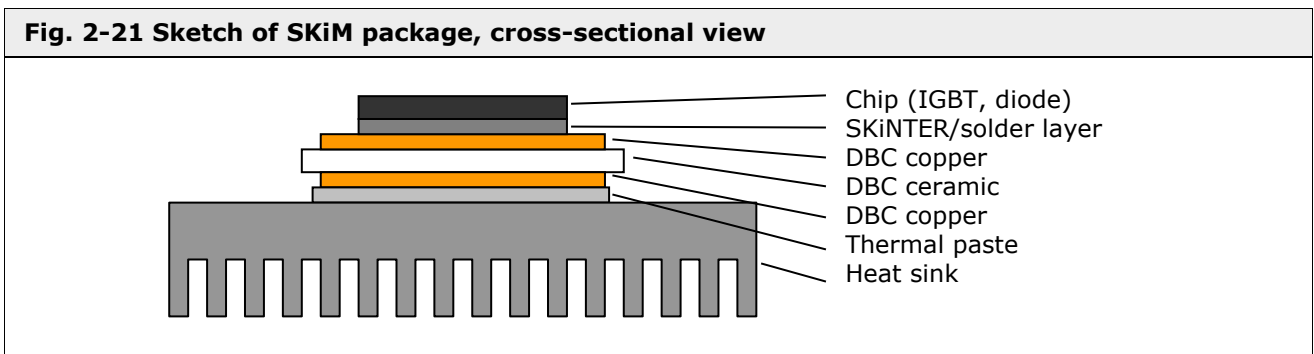

**Tab. 2-3 Material data for thermal simulations**

Layer	Material	Layer thickness	Spec. thermal conductivity	Spec. thermal capacity	Density
		[mm]	[W/m/K]	[J/kg/K]	[kg/m <sup>3</sup> ]
IGBT chip ("066")	Si	0.07	124	750	2330
IGBT chip ("E4")	Si	0.14	124	750	2330
IGBT chip ("17")	Si	0.19	124	750	2330
Diode chip	Si	0.24	124	750	2330
Chip joint	Ag-sinter layer	~ 0.02	250	230	7350
	Solder layer	~ 0.09	57	214	7800
DBC copper	Cu	0.30	390	390	8960
DBC ceramic	Al <sub>2</sub> O <sub>3</sub>	0.38	24	830	3780
DBC copper	Cu	0.30	390	390	8960
Thermal paste	Customer-specific	0.25			
Heat sink	Customer-specific				

## 2.9 Pressure Force on the Heat Sink

For the heat sink design it may be necessary to know what force is applied by the SKiM module. This information is given in Tab. 2-4. The sketch in Fig. 2-22 shows how the values in Tab. 2-4 are to be understood.

**Tab. 2-4 Pressure forces produced by SKiM modules**

		SKiM 63	SKiM 93
Pressure stress per half bridge	[N/mm <sup>2</sup> ]	1.06	1.27

**Fig. 2-22 Sketch of SKiM 63, bottom view**

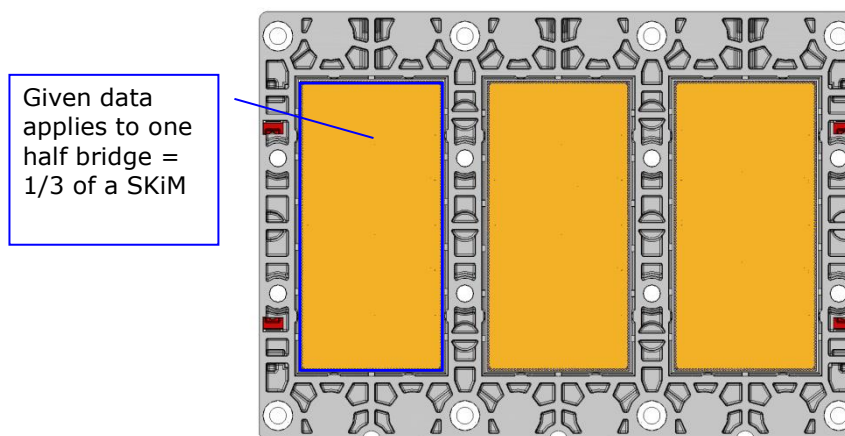

### 3. Chip Technologies and Product Ranges

#### 3.1 IGBT Chip Technologies and Product Range

SKiM IGBT modules are available with 600 V, 650V, 1200 V and 1700 V IGBTs.

##### Design Principles

IGBT chips are based on two different main design principles. The first is related to the gate structure: trench or planar gate, while the second relates to the IGBT technology used: punch through ("PT") or non-punch through ("NPT").

The planar gate is a cost-effective structure based on doping processes and produces a horizontal gate structure. The sophisticated trench gate, in comparison, is based on a combination of doping, etching and filling processes. The trench process leads to a very efficient, vertical gate structure and allows for small chip sizes (Fig. 3-1), which in turn allow for compact module design. Despite this, the smaller chip sizes lead to higher thermal resistance at the same time.

##### Trench IGBT

SEMIKRON type designation: "066" for 600 V, "07" for 650 V, "126" for 1200 V, "17E4" for 1700 V 3<sup>rd</sup> generation "IGBT3", "12F4", "12E4", for the 1200 V 4<sup>th</sup> generation "IGBT4".

The "Trench IGBT" chip design is based on a trench-gate structure combined with a "Field Stop" n<sup>+</sup> buffer layer for punch through feature, as shown in Fig. 3-1. With the introduction of the 4<sup>th</sup> generation, this general design was not changed, but the trade-off between the on-state losses  $V_{CE(sat)}$  and the switching losses  $E_{on}+E_{off}$  was optimised for operation with switching frequencies above 4 kHz.

Furthermore, the "IGBT4" is able to operate with a maximum junction temperature  $T_{j,max} = 175$  °C. The increased  $T_{j,max}$  offers more flexibility in overload conditions or for applications with few temperature cycles (e.g. pumps or fans) where the junction temperature might now exceed the former limits.

**Fig. 3-1 IGBT with trench gate and "Field Stop" technology**

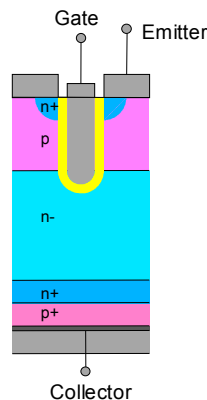

For further information on "IGBT4", please refer to:

- R. Annacker, R. Herzer, *IGBT4 Technology Improves Application Performance*, Bodo's Power Systems, Issue June 2007
- A. Wintrich, *IGBT4 and Freewheeling Diode CAL4 in IGBT Modules*, SEMIKRON Application Note, AN-7005, Nuremberg, 2008

### Inverse and Freewheeling Diodes

The free-wheeling diodes used in SKiM IGBT modules are specially optimized CAL (**C**ontrolled **A**xial **L**ifetime) diodes, or HD CAL (**H**igh **D**ensity CAL) diodes. These fast, "super soft" planar diodes are characterised by the optimal axial profile of the charge carrier life-time.

This leads to:

- Low peak reverse current lowering the inrush current load on the IGBTs in bridge circuits.
- A "Soft" decrease in the reverse current across the entire operating temperature range, which minimizes switching surges and interference.
- A robust performance even when switching at high  $di/dt$ .
- Very good paralleling capability thanks to the negligible negative temperature coefficient and the small forward voltage VF spread.

Compared with CAL diodes, HD CAL diodes display reduced forward voltages at negligible higher switching losses and an almost invariant forward voltage temperature coefficient.

SEMIKRON's newly developed "CAL4" diode is designed specifically for use with the "IGBT4" generation. This new device boasts low thermal losses and outstanding soft switching behaviour even at extreme commutation speeds. Further, the newly developed junction termination ensures safe operation up to 175 °C.

For further information on CAL4, please refer to:

- V. Demuth et al., *CAL 4: The Next-Generation 1200V Freewheeling Diode*, Proceedings PCIM China, 2007

### 3.2 Safe Operating Area for IGBTs

Safe Operating Areas are not included in the datasheets. They are given as standardized figures. These figures apply to 600 V, 650V, 1200 V and 1700 V.

#### Safe Operating Area

IGBT modules must not be used in linear mode.

**Fig. 3-2 Safe Operating Area (SOA)**

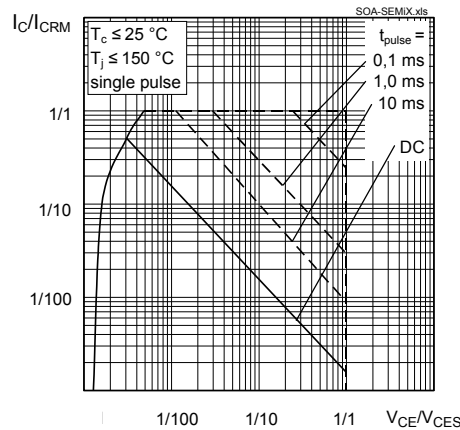

**Reverse Bias Safe Operating Area**

The maximum  $V_{CES}$  value must never be exceeded. Due to the internal stray inductance of the module, a small voltage will be induced during switching. The maximum voltage at the terminals  $V_{CE\max,T}$  must therefore be smaller than  $V_{CE\max}$  (see dotted line in Fig. 3-3). This value can be calculated using the formula (3-1) given below. The value for  $t_f(I_C)$  can be taken from figure 7 of the data sheets.

$$V_{CE\max,T} = V_{CES} - L_{CE} \times \left[ \frac{I_C \times 0.8}{t_f(I_C)} \right] \quad (3-1)$$

**Fig. 3-3 Reverse Bias Safe Operating Area (RBSOA)**

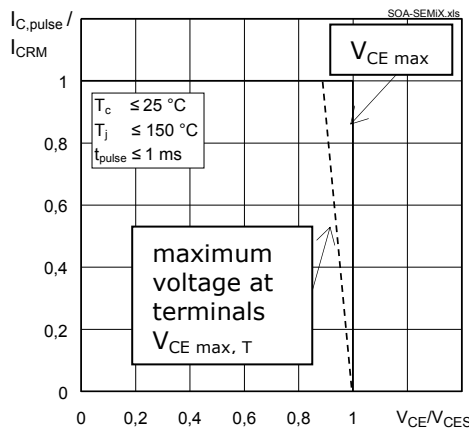

**Short Circuit Safe Operating Area**

The number of short circuits must not exceed 1000. The time between short circuits must be  $> 1\text{ s}$ . The duration time of the short circuit pulse  $t_{psc}$  is limited. Please refer to the maximum values for  $t_{psc}$  given in the data sheet.

**Fig. 3-4 Short Circuit Safe Operating Area (SCSOA)**

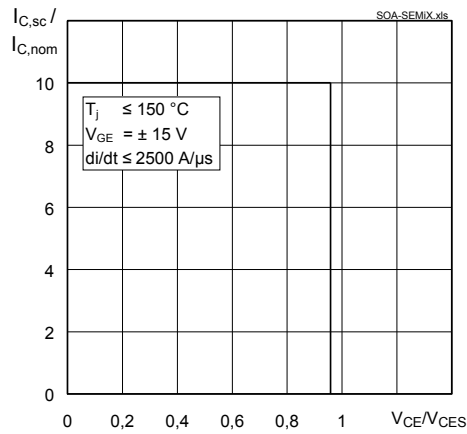

### 3.3 Surge Current Characteristics of CAL Diodes

When the CAL diode operates as a rectifier diode in an "IV-Q" application, it is necessary to know the ratio of the permissible overload on-state current  $I_{F(OV)}$  to the surge on-state current  $I_{FSM}$  as a function of the load period  $t$  and the ratio of  $V_R / V_{RRM}$ .  $V_R$  denotes the reverse voltage applied between the sinusoidal half waves.  $V_{RRM}$  is the peak reverse voltage.

**Fig. 3-5 Surge overload current vs. time**

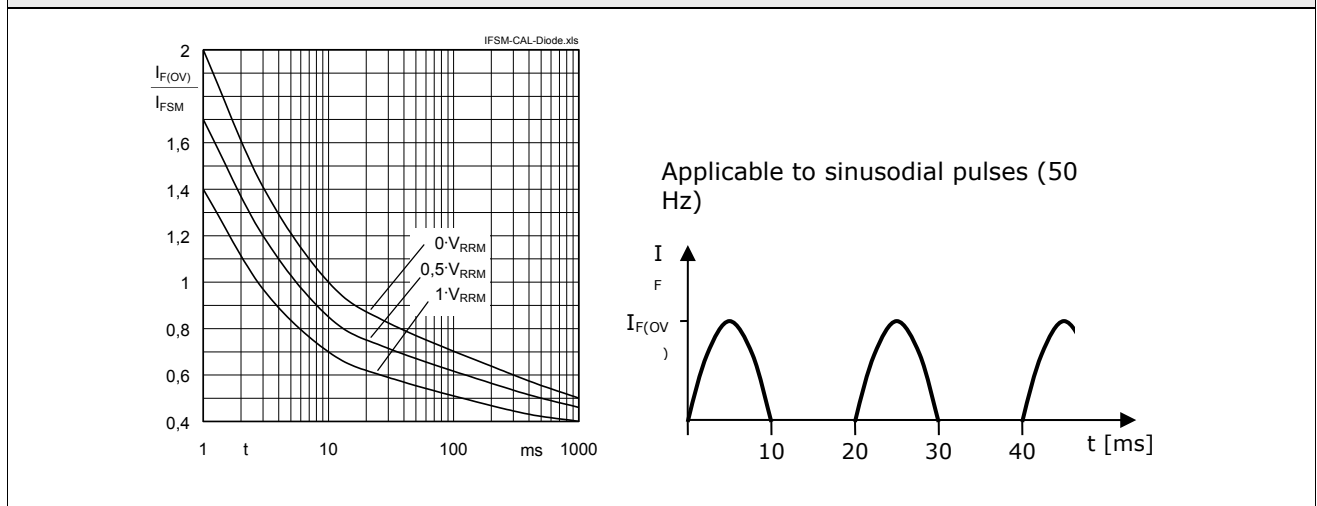

### 3.4 Selection Guide

The correct choice of the IGBT module depends very much on the application itself. A lot of different parameters and conditions have to be taken into account:  $V_{in}$ ,  $I_{in}$ ,  $V_{out}$ ,  $I_{out}$ ,  $f_{switch}$ ,  $f_{out}$ , overload, load cycles, cooling conditions, etc. Due to this variety of parameters a simplified selection guide is not seriously feasible.

For this reason SEMIKRON offers the selection, calculation and simulation tool "SEMISEL" under <https://www.semikron.com/service-support/semisel-simulation.html>. Almost all design parameters can be edited for various input or output conditions. Different cooling conditions can be chosen and specific design needs can be effectively determined.

## 4. Thermal Resistances

### 4.1 Measuring Thermal Resistance $R_{th(j-s)}$

The thermal resistance is defined as given in the following equation (4-1)

$$R_{th(1-2)} = \frac{\Delta T}{P_V} = \frac{T_1 - T_2}{P_V} \quad (4-1)$$

The data sheet values for the thermal resistances are based on measured values. As can be seen in equation (4-1), the temperature difference  $\Delta T$  has a major influence on the  $R_{th}$  value. As a result, the reference point and the measurement method have a major influence, too.

Since SKiM modules have no base plate, the typical case temperature ( $T_c$ ) and hence the  $R_{th(j-c)}$  value cannot be given. Instead, SEMIKRON gives the thermal resistance between the junction and the heat sink  $R_{th(j-s)}$ . This value depends largely on the thermal paste. Thus, the value is given as a "typical" value in the data sheets.

SEMIKRON measures the  $R_{th(j-s)}$  of SKiM modules on the basis of the reference points given in Fig. 4-1. The reference points are as follows:

- $T_j$  - The junction of the chip
- $T_s$  - The heat sink temperature is measured in a drill hole, 2 mm beneath the module, directly under the chip. The 2 mm is derived from our experience, which has shown that at this distance from the DBC ceramic, parasitic effects resulting from heat sink parameters (size, thermal conductivity etc.) are at a minimum and the disturbance induced by the thermocouple itself is negligible.

**Fig. 4-1 Location of reference points for  $R_{th}$  measurement as used for SKiM**

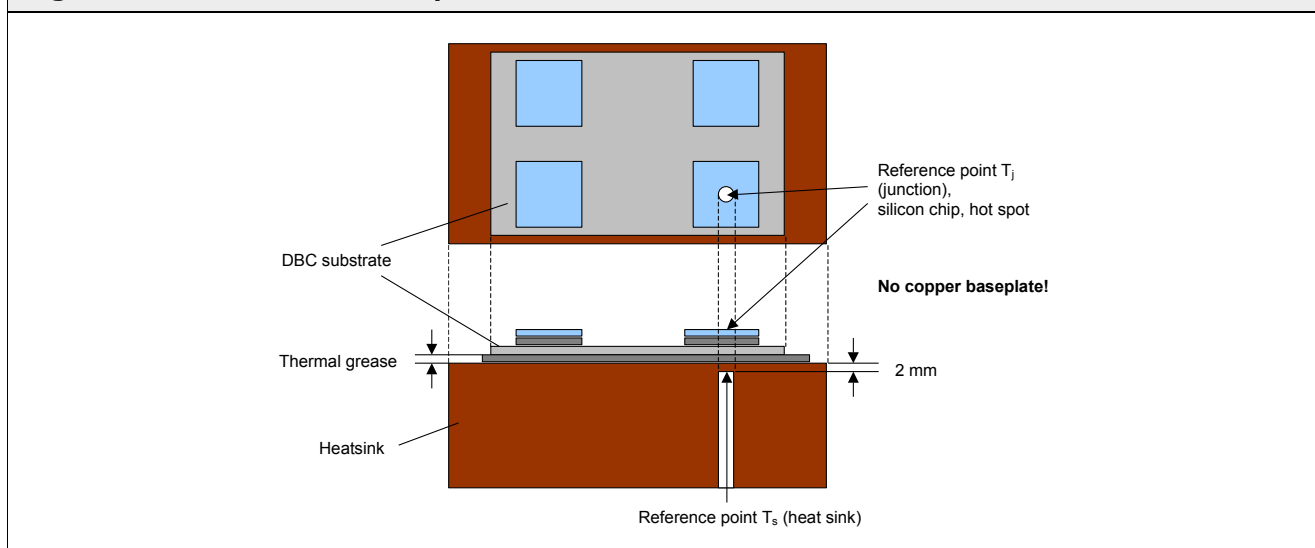

For further information on the measurement of thermal resistances, please refer to:

- M. Freyberg, U. Scheuermann, "Measuring Thermal Resistance of Power Modules"; PCIM Europe, May, 2003

## 4.2 Transient Thermal Impedance

When switching on a “cold” module, the thermal resistance  $R_{th}$  appears smaller than the static value as given in the data sheets. This phenomenon occurs due to the internal thermal capacities of the package (cf. Fig. 2-21). These thermal capacities are “uncharged” and will be charged with the heating energy resulting from the losses during operation. In the course of this charging process the  $R_{th}$  value seems to increase. During this time it is therefore called transient thermal impedance  $Z_{th}$ . When all thermal capacities are charged and the heating energy has to be emitted to the ambience, the transient thermal resistance  $Z_{th}$  will have reached the static data sheet value  $R_{th}$ .

The advantage of this behaviour is the short-term overload capability of the power module.

**Fig. 4-2 Transient Thermal Impedance**

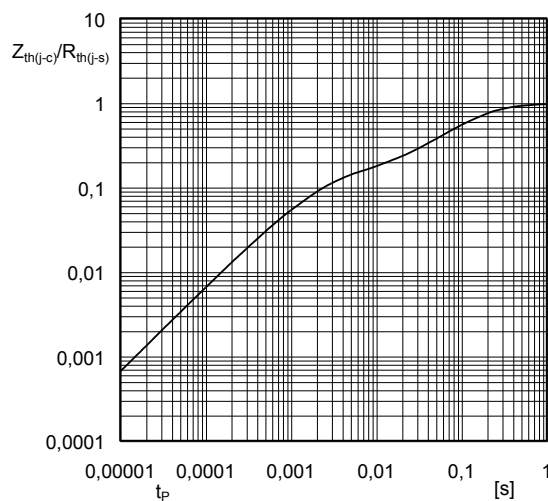

The transient thermal behaviour is measured during SEMIKRON’s module approval process. On the basis of this measurement a mathematical model is derived, resulting in the following equation (4-2):

$$Z_{th}(t) = R_1 \left( 1 - e^{-\frac{t}{\tau_1}} \right) + R_2 \left( 1 - e^{-\frac{t}{\tau_2}} \right) + R_3 \left( 1 - e^{-\frac{t}{\tau_3}} \right) \quad (4-2)$$

For SKiM modules, the coefficients  $R_1$ ,  $\tau_1$ , and  $R_2$ ,  $\tau_2$  can be determined using the data sheet values as given in Tab. 4-1.

**Tab. 4-1 Parameters for  $Z_{th(j-s)}$  calculation using equation (4-2)**

Parameter	Unit	IGBT, CAL diode
$R_1$	[K/W]	$0.11 \times R_{th(j-s)}$
$R_2$	[K/W]	$0.77 \times R_{th(j-s)}$
$R_3$	[K/W]	$0.12 \times R_{th(j-s)}$
$\tau_1$	[sec]	1.0
$\tau_2$	[sec]	0.13
$\tau_3$	[sec]	0.002

## 5. Integrated Temperature Sensor Specifications

All SKiM IGBT modules feature a temperature-dependent resistor for temperature measurement. The resistor is sintered/soldered onto the same DBC ceramic substrate near the IGBT and diode chips and reflects the actual case temperature. Every single half bridge has its own temperature sensor. For the exact locations of these sensors, please refer to Fig. 2-19 and Fig. 2-20. Two different temperature sensor types are available for SKiM, see below chapter for more details. The type of temperature sensor can be found in the corresponding SKiM data sheet.

Since the cooling conditions have a significant influence on the temperature distribution inside SKiM modules, it is necessary to evaluate the dependency between the temperatures of interest (e.g. chip temperature) and the signal from the integrated temperature sensor.

### 5.1 Electrical Characteristic for PTC temperature sensor

The built-in temperature sensor in SKiM is a resistor with a positive temperature coefficient (PTC). Its characteristic is given in **Fig. 5-1**

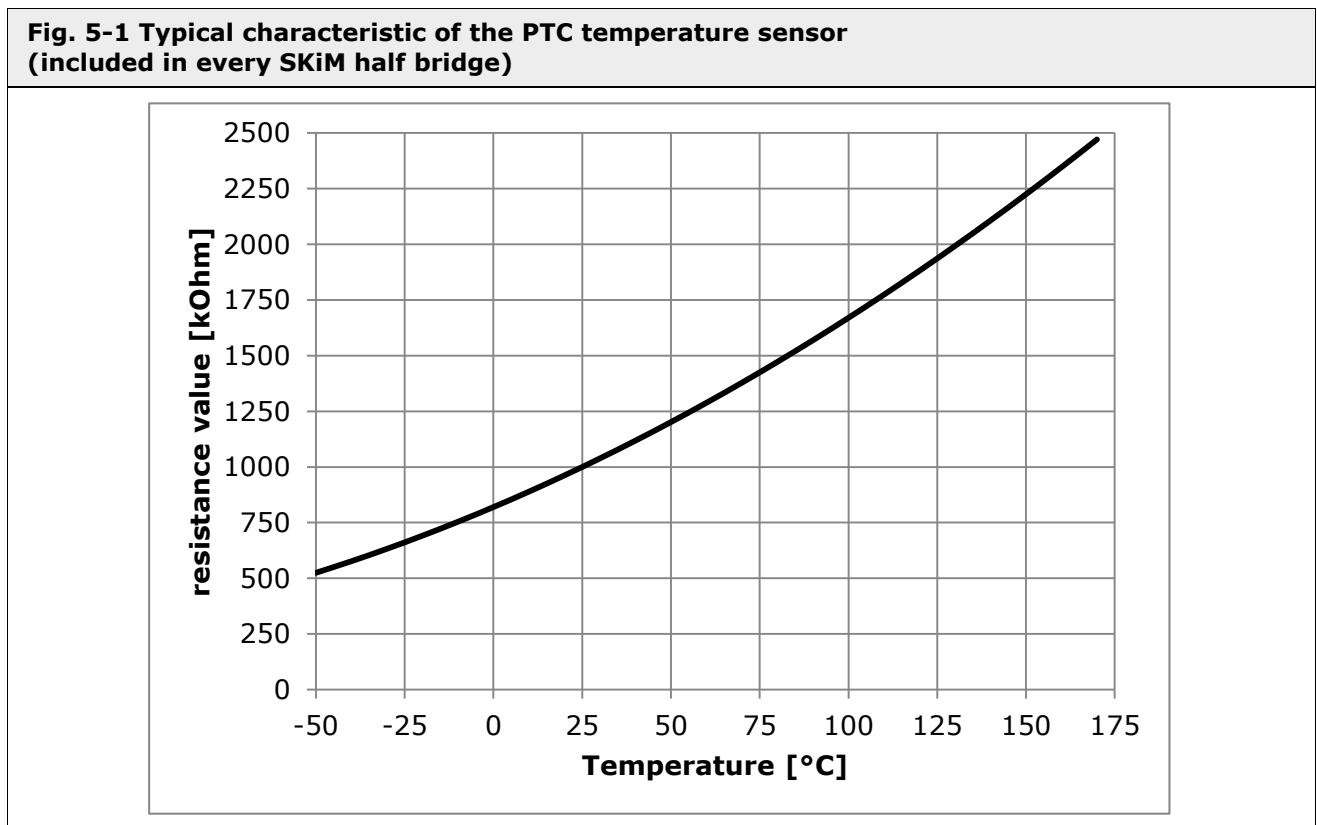

A mathematical approximation (in the range from 80 °C to 150 °C) for the sensor resistance as a function of temperature  $R(T)$  is given by:

$$R(T) = R_{ref} * [1 + A * (T - T_{ref}) + B * (T - T_{ref})^2]$$

$$R_{ref} = 1000\Omega, T_{ref} = 25^\circ\text{C},$$

$$A = 7,64 * 10^{-3} \text{ }^\circ\text{C}^{-1}, B = 1,73 * 10^{-5} \text{ }^\circ\text{C}^2$$

**Tab. 5-1 Resistance values and tolerance**

Symbol	Conditions	min	typ	max	Tolerance (%)	Units
R	$T_j = 25^\circ\text{C}, I_{\text{measurement}} = 1 \text{ mA}$	980	1000	1020	$\pm 2$	$\Omega$
	$T_j = 35^\circ\text{C}, I_{\text{measurement}} = 1 \text{ mA}$	1057	1078,5	1100	$< \pm 2$	$\Omega$
	$T_j = 100^\circ\text{C}, I_{\text{measurement}} = 1 \text{ mA}$	1653	1670	1687	$\pm 1$	$\Omega$

Please note: for correct measurement the pin 29 (see the data sheet for the module pin layout) has to be connected to the positive terminal of the current source. It is recommended to measure at the current of 1mA to avoid the self-heating of the sensor.

## 5.2 Electrical Characteristic NTC temperature sensor

The temperature sensor has a nominal resistance of 5 kΩ at 25 °C. The measuring current should be 1 mA; the maximum value is 3 mA.

The built-in temperature sensor in SKiM is a resistor with a negative temperature coefficient (NTC). Its characteristic is given in Fig. 5-2

A mathematical approximation (in the range from 80 °C to 150 °C) for the sensor resistance as a function of temperature R(T) is given by:

$$R(T) = R_{100} \times \exp[B_{100/125} \times (1/T - 1/T_{100})]$$

With  $R_{100} = 339 \Omega$   
 $B_{100/125} = 4096 \text{ K}$   
 $T_{100} = 100 \text{ °C} = 373.15 \text{ K}$

Please note: absolute values of temperature in K are used, thus temperature is calculated in K, not °C, see the formula below:

$$R(T) = 339 \Omega \times \exp[4096 \times (1/T - 1/373.15 \text{ K})]$$

**Fig. 5-2 Typical characteristic of the NTC temperature sensor (included in every SKiM half bridge)**

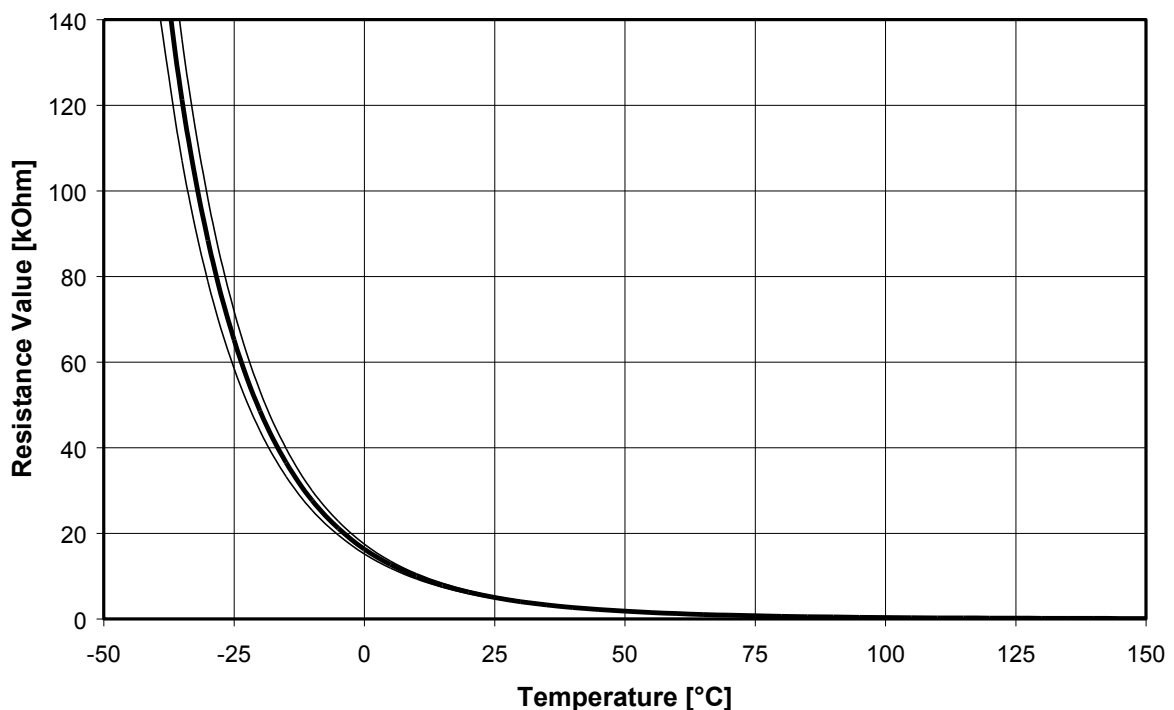

**Fig. 5-3 Characteristic of the NTC temperature sensor with tolerances**

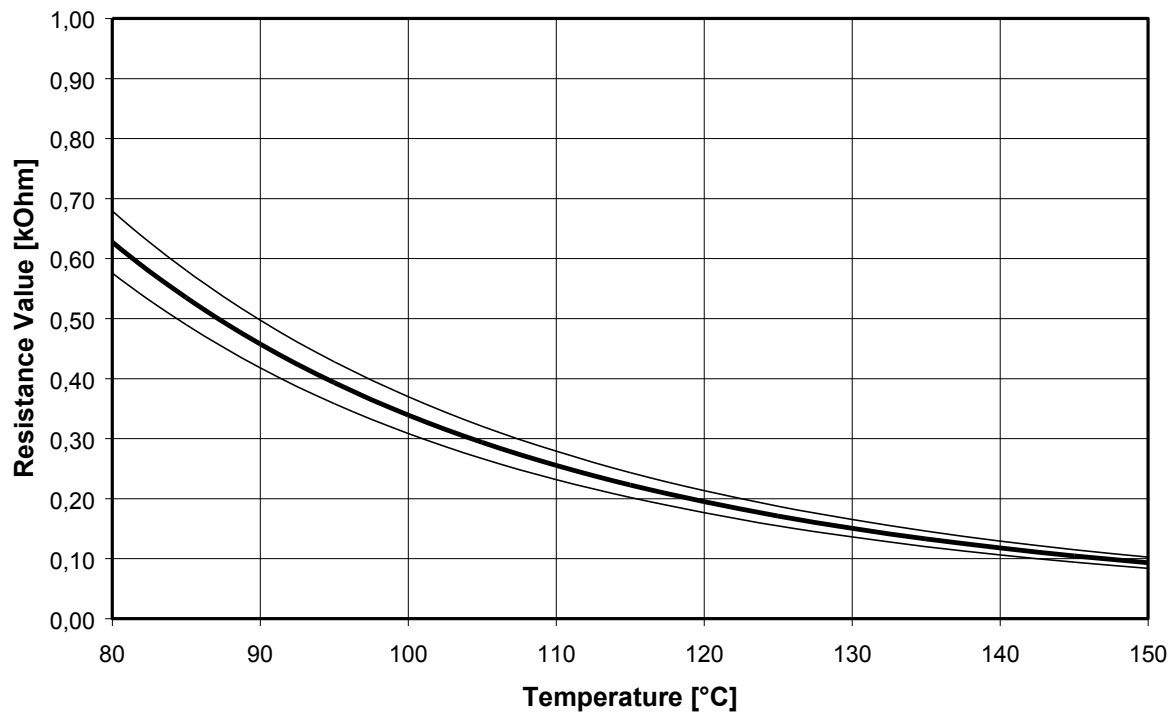

**Tab. 5-2 Resistance values and tolerance**

Temperature [°C]	Resistance Value			Tolerance maximum deviation [%]
	minimum [kΩ]	standard [kΩ]	maximum [kΩ]	
-40	147.237	168.105	188.972	12.4
-30	78.766	88.454	98.141	11.0
-20	43.908	48.555	53.202	9.6
-10	25.394	27.681	29.967	8.3
0	15.180	16.326	17.471	7.0
10	9.335	9.947	10.559	6.2
20	5.910	6.245	6.581	5.4
30	3.813	4.029	4.245	5.4
40	2.504	2.664	2.824	6.0
50	1.682	1.802	1.921	6.6
60	1.153	1.243	1.333	7.2
70	0.807	0.875	0.943	7.8
80	0.576	0.628	0.679	8.3
90	0.418	0.458	0.497	8.7
100	0.308	0.339	0.370	9.1
110	0.232	0.255	0.279	9.2
120	0.176	0.195	0.213	9.4
130	0.136	0.151	0.165	9.6
140	0.106	0.118	0.129	9.8
150	0.084	0.093	0.102	10.0

### 5.3 Electrical Isolation

Inside SKiM modules the temperature sensors are mounted close to the IGBT and diode dice onto the same substrate. The minimum distance between the copper conductors is  $= 0.80 \pm 0.2$  mm. (Fig. 5-4)

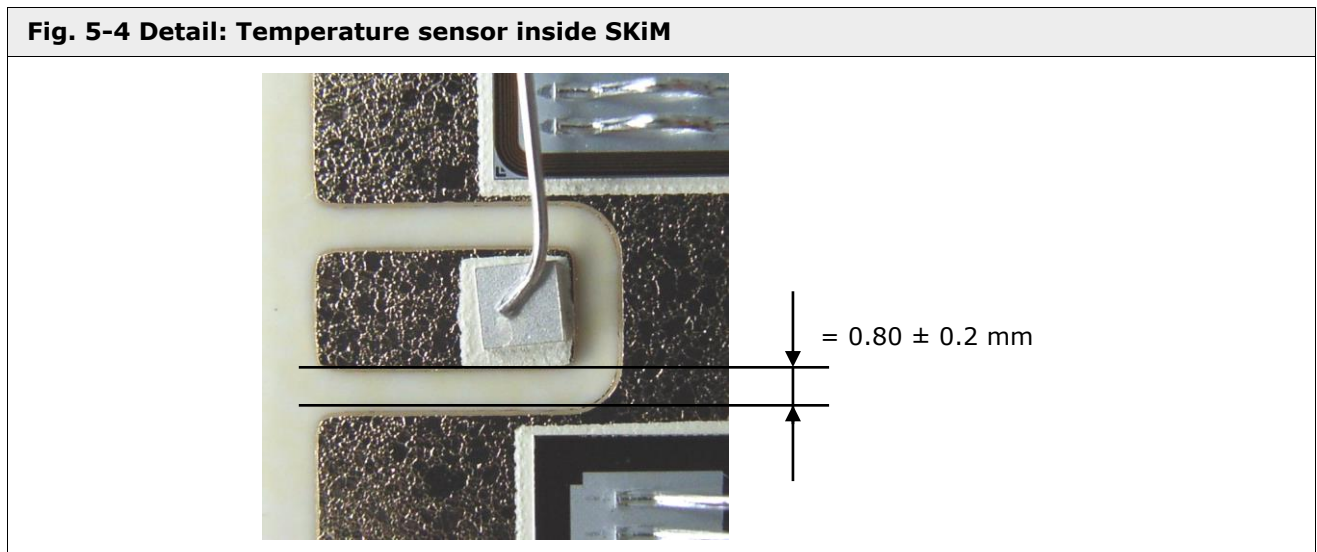

According to EN 61800-5-1, this design does not provide safety protection, because the temperature sensor inside the SKiM module might be exposed to high voltages during semiconductor short-circuit failure mode. After electrical overstress the bond wires could melt off, producing an arc with high-energy plasma in the process (as shown in Fig. 5-5). In this case the direction of plasma expansion is unpredictable and the temperature sensor might come into contact with the plasma.

The safety grade "safety protection" in accordance with EN 61800-5-1 can be achieved by different additional means, which are described in this standard in more detail.

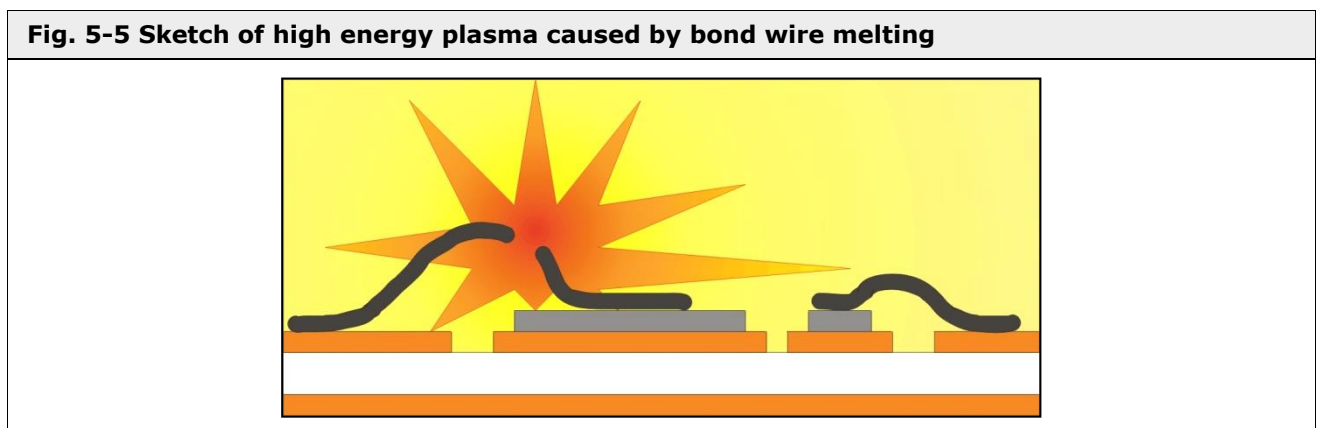

Please note: To ensure that electrical isolation  $V_{isol}$  as stated in the data sheets is provided, suitable measurements are performed during the production process. These are described in section 2.6.

## 6. Spring Contact System Specifications

### 6.1 Spring and Contact Specifications

Tab. 6-1 Specifications for SKiM contact springs		
	Rating / Specification	Comment
Material	Copper: DIN 2076-CuSn6 With silver surface: Abrasiveness 75 to 95 HV, tarnish protection < 0.1 µm	
Contact force	3 to 5 N	
Maximum contact resistance including ageing	- 200 mΩ (current ≤ 1A) - 25 mΩ (current > 1A)	For one spring tested according to IEC 600068-2-43 (10 days, 10 ppm H <sub>2</sub> S, 75 % RH, 25°C)

### 6.2 PCB Specifications (Landing Pads for Springs)

Tab. 6-2 Specifications for the surface metallization of landing pads for SKiM contact springs		
	Rating / Specification	Comment
Chem. Sn (Chemical deposition)	no min. thickness	Intermetallic phases may be contacted
HAL Sn (Hot Air Levelling)	no min. thickness	Intermetallic phases may be contacted
NiAu	Ni ≥ 3µm, Au ≥ 20nm (Electro less nickel, immersion gold)	Tight Ni diffusion barrier required
SnPb	no min. thickness	Intermetallic phases may be contacted

### 6.3 Storage Conditions

Tab. 6-3 Storage conditions for SKiM modules with silver-plated contact springs		
	Rating / Specification	Comment
Unassembled	28 month / 60 °C 95% RH (max. storage time of module is 18 month and limited by pre-applied thermal paste)	After extreme humidity the reverse current limits may be exceeded but do not degrade the performance of the SKiM
Assembled	28 month / 60 °C 95% RH	

### 6.4 Stray Inductance of Contact Springs

The spiral springs look like the coils of an inductor. This would seem to contradict one of the main requirements in power electronics: "low inductance". In measurements, however, these springs have not been shown to have any influence on switching behaviour. The following calculations verify the results obtained in practice.

In this respect, the SKiM module, which features springs and PCB tracks between the driver and the springs, is comparable with a SEMITRANS module, which has internal wiring and wiring between driver and module.

### 6.4.1 Self-Inductance of the Spring Connection

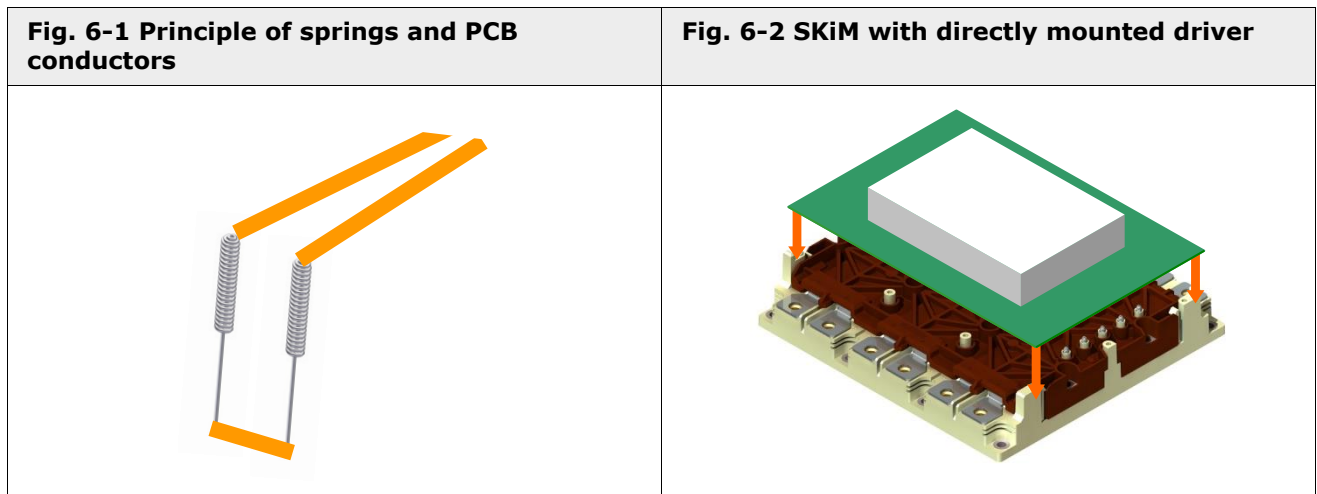

Inductance spiral spring  $L_{SP}$  (with  $l = 5 \dots 10 D$ )

$$L_{SP} = \mu \cdot n^2 \cdot \frac{\pi \cdot D^2}{4 \cdot \sqrt{l^2 + D^2}}$$

$$L_{SP} = 77 \text{ nH}$$

- $\mu$  =  $\mu_0 = 1,26 \text{ } \mu\text{H/m}$
- $l$  = 11.5 mm (length, spring under pressure)
- $D$  = 1.5 mm (inner diameter)
- $n$  = 20 (number of coils)

Inductance PCB tracks  $L_{PCB}$

$$L_{PCB} = \frac{l \cdot 2 \cdot \mu}{\pi} \cdot \ln \left( 1 + \frac{a}{d+b} \right)$$

$$L_{PCB} = 31 \text{ nH}$$

- $\mu$  =  $\mu_0 = 1.26 \text{ } \mu\text{H/m}$
- $l$  = 100 mm (length spring pad to driver output stage)
- $a$  = 0.5 mm (distance between conductors on PCB)
- $d$  = 50  $\mu\text{m}$  (thickness of copper layer)
- $b$  = 1 mm width of the copper track

Total:  $L_{SP} + L_{PCB} = 108 \text{ nH}$

## 7. Reliability

### 7.1 Standard Tests for the Qualification of SKiM Modules

The objectives of the test program are:

1. Assure the general product quality and reliability.
2. Evaluate design limits by stressing under a variety of testing conditions.
3. Ensure the consistency and predictability of the production processes.
4. Appraise process and design changes regarding their effect on reliability.

The SKiM63/93 modules are available in two versions: starting on Q4 2018 the solder version of SKiM63/93 is available. The standard qualification test for sinter version is available in Tab. 7-1.

<b>Tab. 7-1 SEMIKRON standard qualification tests for sinter modules</b>	
<b>Reliability Test</b>	<b>Standard Test Conditions for SKiM IGBT Modules</b>
High Temperature Reverse Bias (HTRB) <i>IEC 60747</i>	1000 h, $V_{CE} = 95 \% V_{CEmax}$ , $T_c = 160\text{ }^\circ\text{C}$
High Temperature Gate Bias (HTGB) <i>IEC 60747</i>	1000 h, $\pm V_{GEmax}$ , $T = 175\text{ }^\circ\text{C}$
High Humidity High Temperature Reverse Bias (THB) <i>IEC 60068-2-67</i>	1000 h, 85 °C, 85 % RH, $V_{CE} = 80 \% V_{CEmax}$ , $V_{CEmax}$ , max. 80 V, $V_{GE} = 0\text{ V}$
High Temperature Storage (HTS) <i>IEC 60068-2-2</i>	1000 h, + 135 °C
Low Temperature Storage (LTS) <i>IEC 60068-2-1</i>	1000 h, - 40 °C
Thermal Cycling (TC) <i>IEC 60068-2-14 Test Na</i>	500 cycles, - 40 °C to + 125 °C
Power Cycling (PC) <i>IEC 60749-34</i>	25.000 load cycles, $\Delta T_j = 110\text{ K}$
Vibration <i>IEC 60068-2-6 Test Fc</i>	Sinusoidal sweep, 10g, 2 h per axis (x, y, z)
Mechanical Shock <i>IEC 60068-2-27 Test Ea</i>	Half sine pulse, 100g, 3 times each direction ( $\pm x, \pm y, \pm z$ )

The standard qualification test for solder version is available in Tab. 7-2.

<b>Tab. 7-2 SEMIKRON standard qualification tests for solder modules</b>	
<b>Reliability Test</b>	<b>Standard Test Conditions for SKiM IGBT Modules</b>
High Temperature Reverse Bias (HTRB) <i>IEC 60747</i>	1000 h, $V_{CE} = 95 \% V_{CEmax}$ , $T_c = 160\text{ °C}$
High Temperature Gate Bias (HTGB) <i>IEC 60747</i>	1000 h, $\pm V_{GEmax}$ , $T = 175\text{ °C}$
High Humidity High Temperature Reverse Bias (THB) <i>IEC 60068-2-67</i>	1000 h, 85 °C, 85 % RH, $V_{CE} = 80 \% V_{CEmax}$ , $V_{CEmax}$ , max. 80 V, $V_{GE} = 0\text{ V}$
High Temperature Storage (HTS) <i>IEC 60068-2-2</i>	1000 h, + 135 °C
Low Temperature Storage (LTS) <i>IEC 60068-2-1</i>	1000 h, - 40 °C
Thermal Cycling (TC) <i>IEC 60068-2-14 Test Na</i>	100 cycles, - 40 °C to + 125 °C
Power Cycling (PC) <i>IEC 60749-34</i>	20.000 load cycles, $\Delta T_j = 110\text{ K}$
Vibration <i>IEC 60068-2-6 Test Fc</i>	Sinusoidal sweep, 10g, 2 h per axis (x, y, z)
Mechanical Shock <i>IEC 60068-2-27 Test Ea</i>	Half sine pulse, 100g, 3 times each direction ( $\pm x, \pm y, \pm z$ )

## 7.2 Reliability of Spring Contacts

The SKiM spring contact for the auxiliaries is a solder-free contact. It can therefore be compared with other solder-free contacts such as screw terminals or plug connectors.

The surface materials for the spring contacts as given in Fig. 6-1 and Tab. 6-2 (silver-plated spring and, for example, tin surface for PCB landing pads) are based on "state-of-the-art" knowledge as gained from long-term experience with plug connectors and SEMIKRON's long-term experience with spring connections. Compared to a plug connector, the spring contact has a far greater pressure and contact force, which accounts for the superior reliability of this connection.

To verify this reliability, several harsh tests were performed on the spring contacts: temperature cycling, temperature shock tests, fretting corrosion (= micro vibration), electromigration, and a corrosive atmosphere test in accordance with IEC 60068-2-43:

- Atmosphere: 10 ppm H<sub>2</sub>S
- Temperature: 25 °C
- Relative humidity: 75 %
- Volume flow: > volume x 3 per hour

- Duration: 10 days
- No current load during storage

All of these tests were passed successfully and demonstrated the outstanding reliability of SEMIKRON's spring contacts.

It goes without saying that SKiM modules passed all SEMIKRON standard reliability tests as given in Tab. 7-1 or Tab. 7-2

For further information on the reliability of spring contacts, please refer to:

- F. Lang, Dr. U. Scheuermann, "Reliability of spring pressure contacts under environmental stress", Proc. Microelectronics Reliability Volume 47, Issues 9-11, September-November 2007, (18th European Symposium on Reliability of Electron Devices, Failure Physics and Analysis)

### 7.3 Reliability of SKiNTER Layer

In power semiconductor modules different materials with different coefficients of thermal expansion are soldered together. Owing to this material bond, the layers cannot expand and release freely when temperature changes occurs, the result being thermally induced mechanical stress. The longer the joint, the more stress is induced and the more fatigue occurs.

The illustrations in Fig. 7-1 and Fig. 7-2 show the package of different materials. Based on the materials shown in Tab. 7-3, temperature differences  $T-T_{sink}$  are given as resulting under similar operating conditions in these packages. With the coefficient of thermal expansion  $\alpha$  the elongation ratio  $\Delta L/L_0$  induced by the thermal expansion inside the package is calculated by equation

$$\frac{L-L_0}{L_0} = \frac{\Delta L}{L_0} = \alpha \cdot (T - T_{Sink})$$

The materials cannot, of course, expand freely. Thus the difference of the figures for the theoretical expansion is an indicator for the resulting thermally induced stress in the bonding layer between these materials.

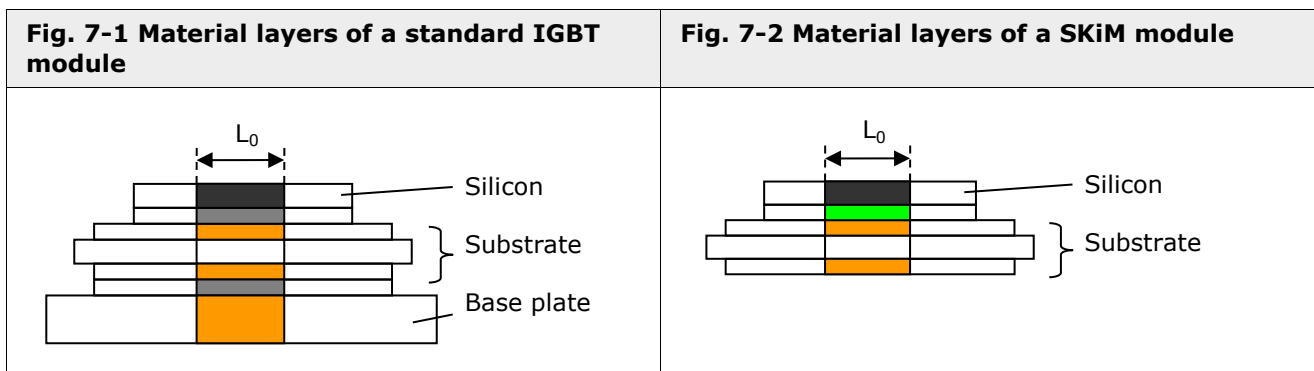

Tab. 7-3 Temperatures and thermal expansion for packages as shown in Fig. 7-1 and Fig. 7-2						
	Standard IGBT module			SKiM module		
	T-Tsink	$\alpha$	$\Delta L/L_0$	T-Tsink	$\alpha$	$\Delta L/L_0$
	in K	in 10 <sup>-6</sup> 1/K		in K	in 10 <sup>-6</sup> 1/K	
Silicon	69.0	4.1	0.28	69.3	4.1	0.28
Substrate	54.4	8.3	0.45	55.3	8.3	0.46
Base plate	36.9	17.5	0.50			

The fatigue in the joint layers can be seen in the increase in thermal resistance. The increase in thermal resistance causes the chip temperature to increase too, because the output power remains unchanged. The increase in chip temperature in turn leads to an increase of  $T-T_{\text{sink}}$ , leading to even more stress in the layers and accelerating the fatigue.

Solder layers, in particular, demonstrate aging as described above. This is due to the fact that the operation temperature of the module (125 °C to 150 °C) is very close to the melting temperature of the solder (220 °C to 250 °C), making the solder layer weak. With the SKiNTER layer the operation temperature is far below the melting point of silver (960 °C). In turn, the SKiNTER technology does not display this accelerated fatigue.

Practical investigations have verified the theoretical considerations. Fig. 7-3 shows the results of power cycling tests with soldered and sintered IGBT modules. The solder layer fatigue and the accelerated aging process lead to an increase in thermal resistance and module failure after 40 000 cycles.

The thermal resistance of the sintered layer does not increase. Modules in SKiNTER technology boast a >30% longer service life and improved reliability.

**Fig. 7-3 Change in thermal resistance during active power cycle tests**

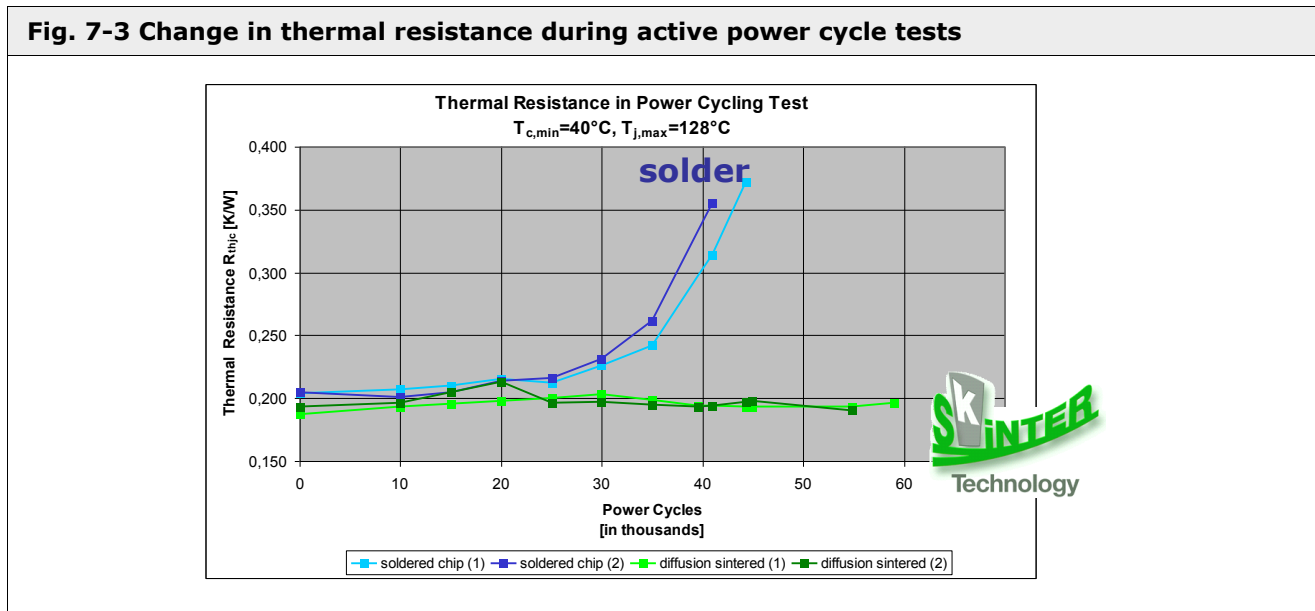

For further information on the reliability of solder-free IGBT modules, please refer to:

- Dr. U. Scheuermann, P.Beckedahl, "The Road to the Next Generation Power Module - 100% Solder Free Design", Proc. CIPS 2008, ETG-Fachbericht 111, 111-120, Nuremberg, 2008.

## 8. Design Recommendations for SKiM

The following recommendations are tips only and do not constitute a complete set of design rules. The responsibility for proper design remains with the user of the SKiM modules.

### 8.1 Printed Circuit Board Design

#### 8.1.1 PCB Specification

Recommendations for the printed circuit board:

- "FR 4" material can be used as a material for the printed circuit board.
- The thickness of copper layers should comply with IEC 326-3.
- The landing pads must not contain plated-through holes ("VIAs") to prevent contact deterioration. In the remaining area VIAs can be used as desired.
- The landing pads for the auxiliary contacts must have a diameter of  $\varnothing = 3.5 \text{ mm} \pm 0.2 \text{ mm}$ .
- As stated in section "PCB Specifications (Landing Pads for Springs)", pure tin (Sn) is an approved interface for use with SKiM spring contacts. Sufficient plating thickness must be guaranteed in accordance with the PCB manufacturing process. The tin surface is normally applied to the PCB chemically or in a hot-air levelling process.  
A second approved surface for the landing pads is electro-less nickel with a final immersion gold layer (Ni + Au).  
Not recommended for use are boards with "organic solder ability preservative" (OSP) passivation, because OSP is not suitable for guaranteeing long-term corrosion-free contact. The OSP passivation disappears during soldering or after approximately 6 months of storage.
- During the solder processes the landing pads for SKiM spring contacts need to be covered and protected from contamination. This is particularly crucial for wave soldering. No residue of the cover material must be left on the landing pads as this could lead to deterioration of the electrical contact in the long term.

#### 8.1.2 PCB Alignment Support

SKiM offers a special alignment support for the printed circuit board and makes the assembly "poka yoke proof". (For PCB mounting please refer to the mounting instructions)

As shown in Fig. 8-1 SKiM has three guide pins. Thanks to these pins, the PCB can be easily placed on the module. There is no pin in the fourth corner. Only one method of assembly is possible if the PCB is shaped with three notches as shown in Fig. 8-2 and Fig. 8-3.

The SKiM also has two alignment rings, which are used to put the PCB in position irrespective of the guiding pins.

For detailed case drawings please refer to the data sheet.

**Fig. 8-1 SKiM with 3 x guiding pins and 2 x alignment rings, pressure part in pressed down position.**

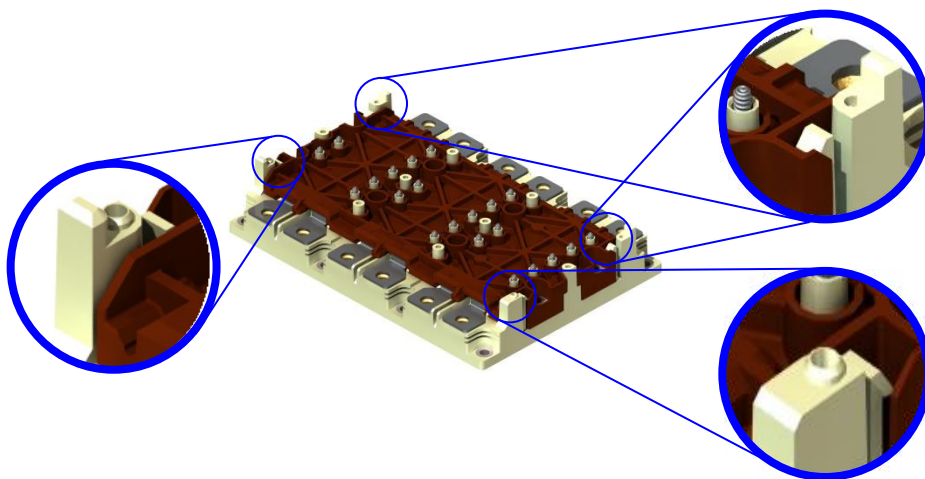

### 8.1.3 PCB Outline, Location of Landing Pads

The following drawings show the outline of a PCB for SKiM 63 (Fig. 8-2) and for SKiM 93 (Fig. 8-3). The drawings show:

- The outer dimensions of the PCB itself
- The location and dimensions of the drill holes
- The location and dimensions of the landing pads

Please note: the layout of the landing pads for SKiM 63 and SKiM 93 is the same. Only the width of the PCB and the location of the drill holes for mounting is different.

**Fig. 8-2 Landing pads layout for SKiM 63 (bottom view)**

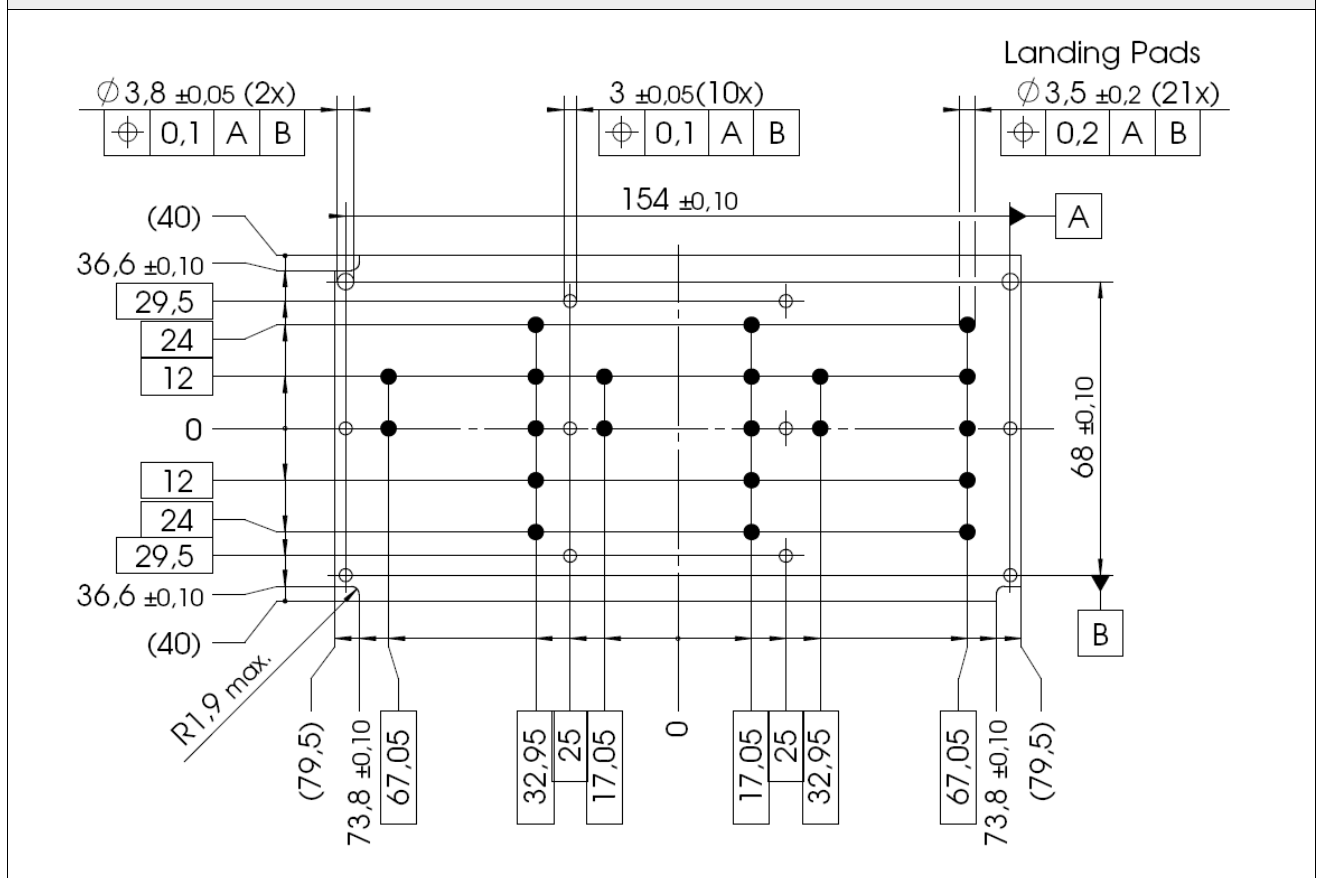

**Fig. 8-3 Landing pads layout for SKiM 93 (bottom view)**

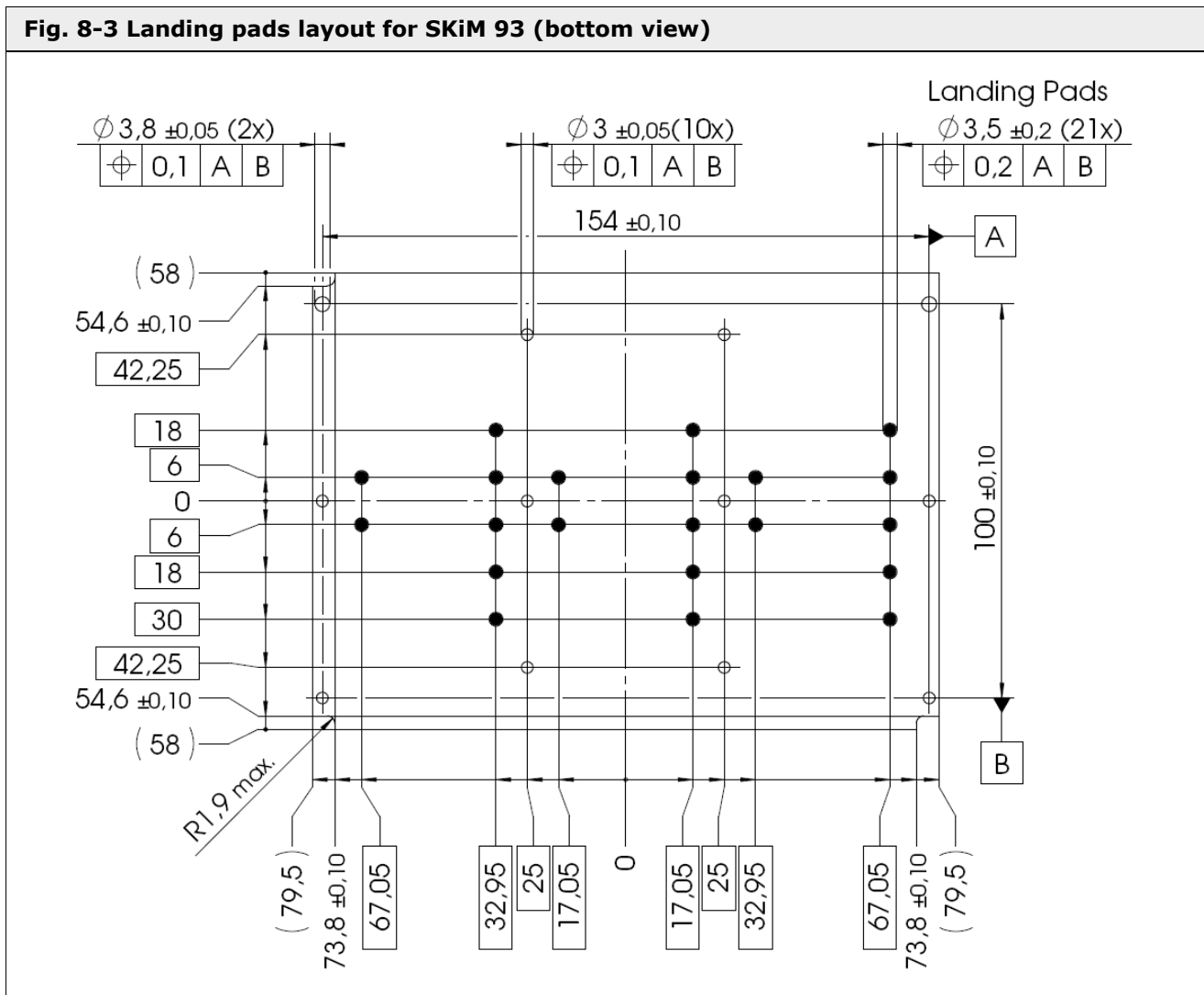

### 8.1.4 General Design Rules

The following general design rules should be taken into account when developing an IGBT driver circuit:

- To suppress interference in the gate signals, magnetic coupling of any kind between the main current and the gate circuits has to be avoided. This can be achieved, for example, by using short gate and emitter connections, whose tracks should be led parallel and very close to each other, i.e. "no open loops". Furthermore, the tracks should be in line with the main magnetic field = 90° to the main current flow  $I_C$ .
- IGBT modules need to be turned off by a negative gate voltage  $V_{G\text{Off}}$ . Otherwise unwanted switch-on via Miller capacitance  $C_{res}$  may occur.
- For short-circuit switch-off, a soft-switch-off circuit in the gate drive circuit (e.g. increased  $R_{G\text{off}}$ ) is recommended to decrease the voltage overshoots in this particular case. SEMIKRON's SKYPER® PRO offers this feature.

### 8.1.5 Gate Clamping

To ensure that the gate voltage  $V_{GE}$  does not exceed the maximum value stated in the data sheet, the use of an appropriate gate clamping circuit (e.g. two anti-serial Z-diodes DGE,  $V_Z = 16\text{ V}$ , as shown in Fig. 8-4) is recommended. This circuit has to be placed as close to the auxiliary contacts as possible.

It is necessary to ensure that the IGBT is always in a defined state, especially in cases where the driver is not able to deliver a defined gate voltage  $V_{GE}$ . A suitable solution to this problem is to use a resistor between gate and emitter  $R_{GE}$  ( $\approx 20\text{ k}\Omega$ ).

This circuit is meant as an addition to the circuit shown in Fig. 8-8

**Fig. 8-4 Gate clamping circuit**

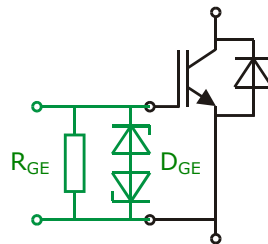

### 8.1.6 Connection of Unused Springs for GAL and GAR Types

SKiM modules are always equipped with all auxiliary springs (as shown in Fig. 8-5) regardless of which circuit is inside. This means landing pads as given in Fig. 8-2 and Fig. 8-3 are necessary in any case. For GAL and GAR types the unused springs (marked red in Fig. 8-6 and Fig. 8-7) must be put on a defined voltage potential - normally 0 V. Otherwise displacement currents might lead to disturbance.

**Fig. 8-5 Pinout of "GD type" (sixpack)**

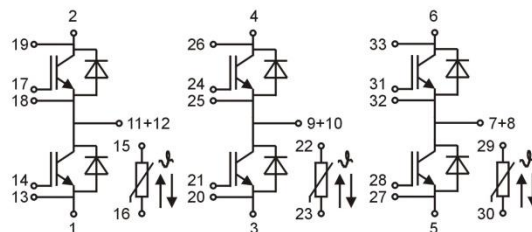

**Fig. 8-6 Pinout of "GAL type"**

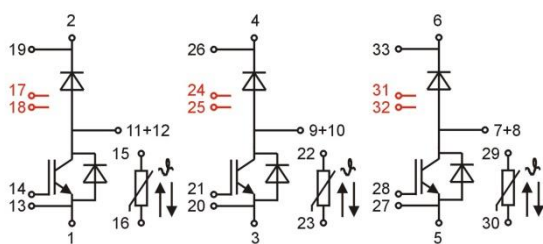

**Fig. 8-7 Pinout of "GAR type"**

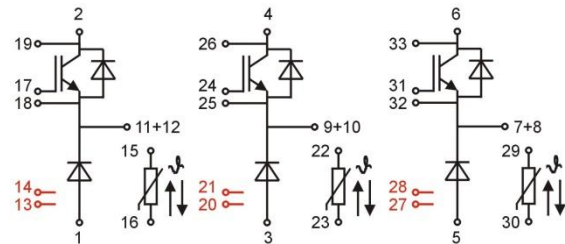

## 8.2 Paralleling SKiM IGBT Modules

When paralleling SKiM IGBT modules it is necessary to provide gate signal decoupling as well as homogeneous and low-inductance AC and DC connections.

### 8.2.1 Paralleling of Gate and Emitter Connections

For optimum and smooth switching behaviour for all paralleled IGBTs it is necessary to ensure decoupling of the gate signals. For this reason every single gate needs its own gate resistor  $R_{G,x} (\geq 2 \Omega)$ , as shown in Fig. 8-8.

Paralleled IGBT modules and half bridges must be controlled by one driver. When using single drivers, there is no way of ensuring that all IGBTs switch simultaneously, meaning that the current distribution between these modules will not be even.

Furthermore, in Fig. 8-8 resistors  $R_{E,x}$  ( $\geq 0.5 \Omega$ ) can be seen at every emitter contact. These resistors are also necessary to ensure homogeneous switching of the paralleled IGBTs. Additionally, these resistors dampen cross currents in the network resulting from main and auxiliary emitter paralleling. The additional Shottky diode (100 V, 1 A) parallel to  $R_{E,x}$  ensures the safe turn-off of high currents (e.g. if a short-circuit occurs).

To achieve similar parasitic inductances and homogeneous switching behaviour, the conductor lengths from the supply point to the individual gate and emitter connections should have the same length for all paralleled IGBTs.

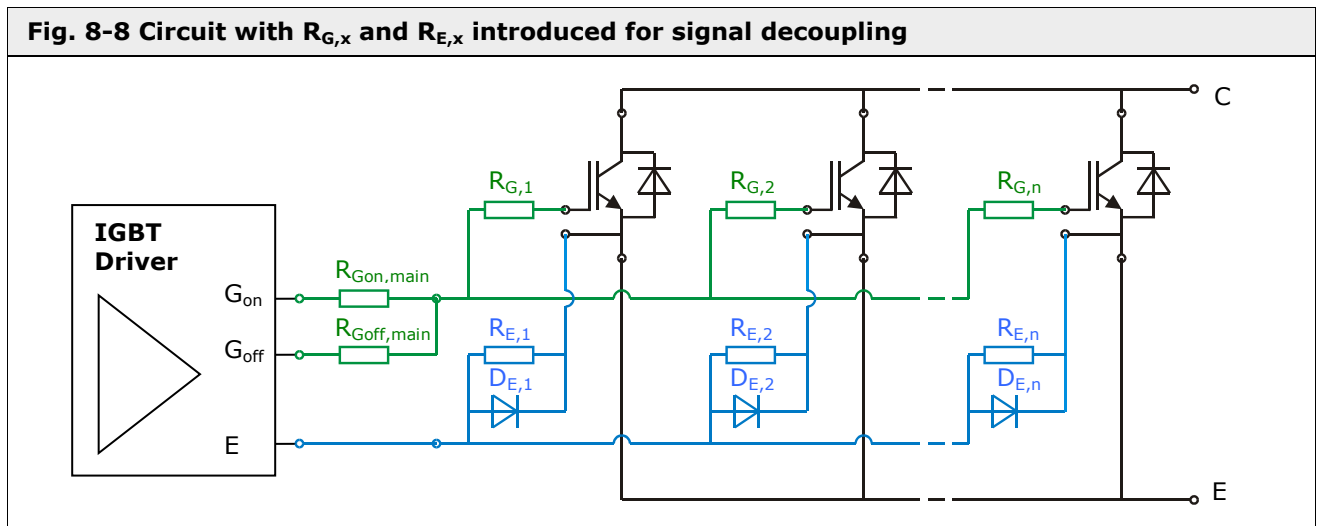

### 8.2.2 Main Terminal Paralleling

For optimum current distribution it is necessary for all parasitic stray inductances to be the same for every module. The same loop length for all connections is a good indicator for the same inductance. Fig. 8-9 shows an optimised AC connection: the length from all module terminals to the output is the same and all terminals are shorted very close to the module, keeping them on the same voltage potential.

(Note: an additional mechanical support is recommended to prevent excessive mechanical forces at the terminals – refer also to the mounting instructions)

The same rules apply to the DC connection. Here, the point of supply from the rectifier should also be central and not from one side. This ensures very similar stray inductances at the DC terminals, too.

**Fig. 8-9 Paralleled SKiM with low inductance DC link and symmetric AC link for optimised current distribution**

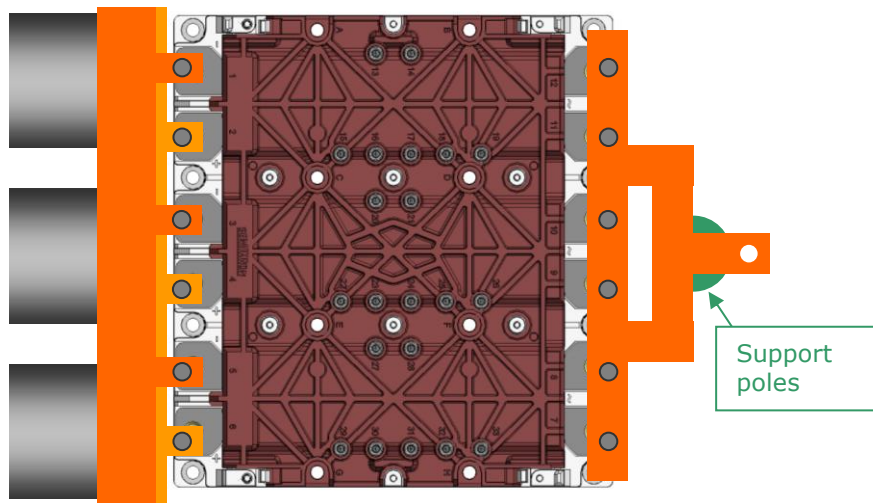

### 8.3 DC Link Bus Bars, Snubber Capacitors

Due to stray inductances in the DC link, voltage overshoots as shown in Fig. 8-10 occur during IGBT switch-off (caused by the energy which is stored in the stray inductances). These voltage overshoots may destroy the IGBT module because they are added to the DC link voltage and may lead to  $V_{CE} > V_{CES}$ .

First of all, the stray inductances have to be reduced to the lowest possible limit. This includes the low-inductance DC link design, as well as the use of low-inductance DC link capacitors. The use of snubber capacitors with a very low stray inductance, a low "ESR" Equivalent Series Resistance and a high "IR" Ripple Current Capability is recommended.

**Fig. 8-10 Voltage overshoots as caused by parasitic inductances**

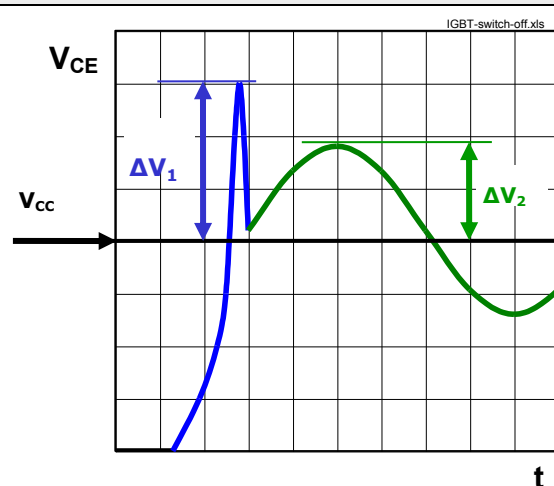

$$\Delta V_1 = L_{\text{stray-snubber}} \times di_C/dt$$

$$\Delta V_2 = \frac{L_{\text{stray-DC-bus}} \times i_C^2}{C_{\text{snubber}}}$$

$i_C$  = Operating current

$di_C/dt$  = During switch-off

$V_{CC}$  = DC link voltage

Furthermore, a pulse capacitor as snubber (see Fig. 8-11 and Fig. 8-12) should be placed between the +/- DC terminals of the SKiM. This snubber works as a low-pass filter and "takes over" the voltage overshoot. Typical values for these capacitors are from 0.1  $\mu\text{F}$  to 1.0  $\mu\text{F}$ . Proper measurements should be performed to ensure that the right snubber is selected.

**Fig. 8-11 Recommended snubber capacitor type.**

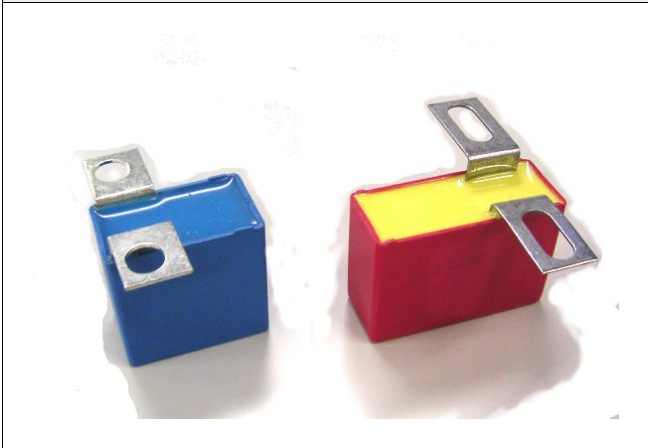

**Fig. 8-12 Non-recommended snubber (too high a stray inductance).**



For further information on snubber capacitors, please refer to:

- J. Lamp, IGBT Peak Voltage Measurement and Snubber Capacitor Specification, Semikron Application Note, AN-7006, Nuremberg, 2008.

## 9. Marking

### 9.1 "Passed" marking on housing

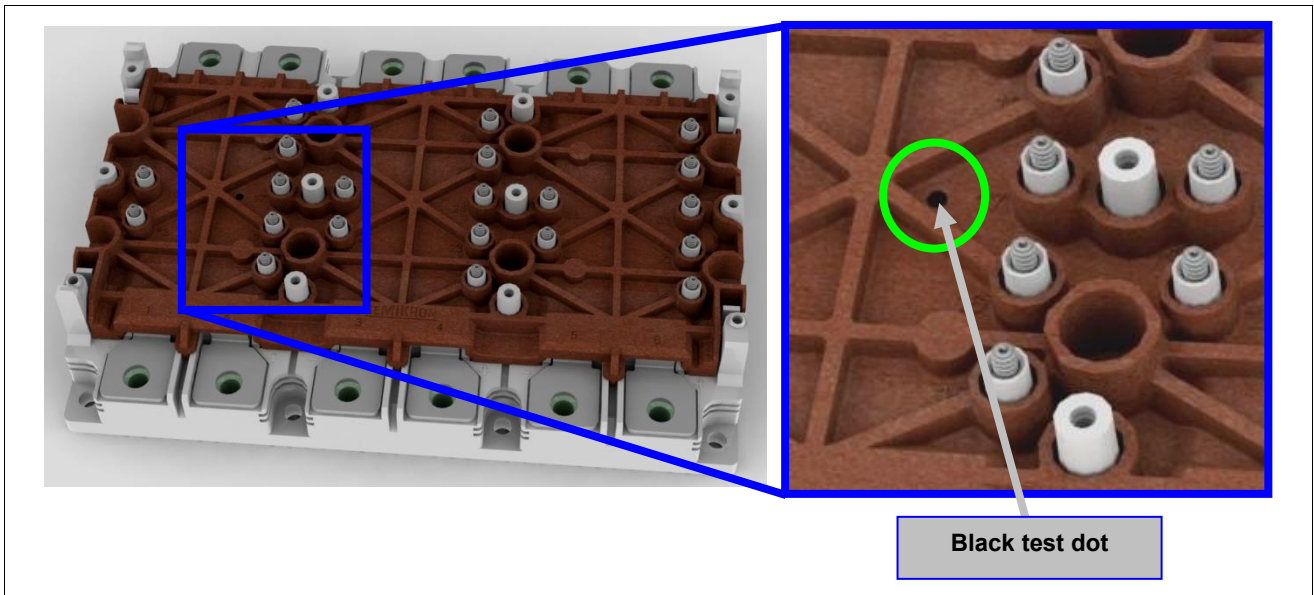

Pre-assembled housings are 100% in-line tested.  
A "passed" test result will be marked with a black dot.

### 9.2 Laser Marking for Modules

All SKiM modules are laser marked. The marking contains the following items (see Fig. 9-1):

**Fig. 9-1 Typical laser marking of SKiM module**

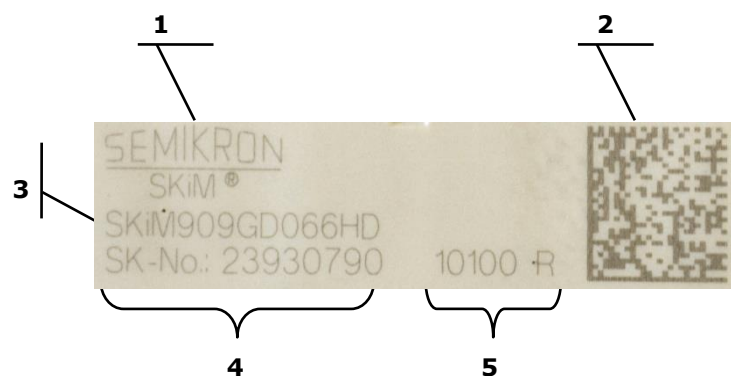

- 1 SEMIKRON logo, with product line designation "SKiM®"
- 2 Data Matrix Code (refer also to section "Data Matrix Code")
- 3 Type designation, for details refer to section "Type Designation System"
- 4 SEMIKRON order code
- 5 Date code – 5 digits: YYMML (L = Lot of same type per week)  
The date code might be followed by
  - "R" if the module is in accordance with the RoHS directive
  - "E" for mechanical, evaluation, engineering or application samples, for the type of sample please refer to the accompanying documents.

### 9.3 Data Matrix Code

The Data Matrix Code is described as follows:

- Type: ECC 200
- Standard: ISO / IEC 16022
- Cell size: 0.3 mm
- Field size: 26 x 26
- Dimension: 8 x 8 mm plus a guard zone of 1 mm (circulating)
- The following data is coded:

<b>1</b>	<b>2</b>	<b>3</b>	<b>4</b>	<b>5</b>	<b>6</b>	<b>7</b>	<b>8</b>	<b>6</b>	<b>10</b>	<b>11</b>
SKiM909GD066HD		23930790	0DE050091001		1	5		0006		10100
<b>1</b>	16 digits	Type designation		<b>7</b>	1 digit	Line identifier (production)				
<b>2</b>	1 digit	Blank		<b>8</b>	1 digit	Blank				
<b>3</b>	10 digits	Part number		<b>9</b>	4 digits	Continuous number				
<b>4</b>	12 digits	Production tracking number		<b>10</b>	1 digit	Blank				
<b>5</b>	1 digit	Blank		<b>11</b>	5 digits	Date code				
<b>6</b>	1 digit	Measurement number								

Total: 53 digits maximum

## 10. Bill of Materials

Detailed MCDS is available for SKiM<sup>®</sup>63 and SKiM<sup>®</sup>93. Please address your request to your SEMIKRON sales representative.

**Fig. 10-1 Explosion picture of SKiM<sup>®</sup>63 to illustrate the parts used**

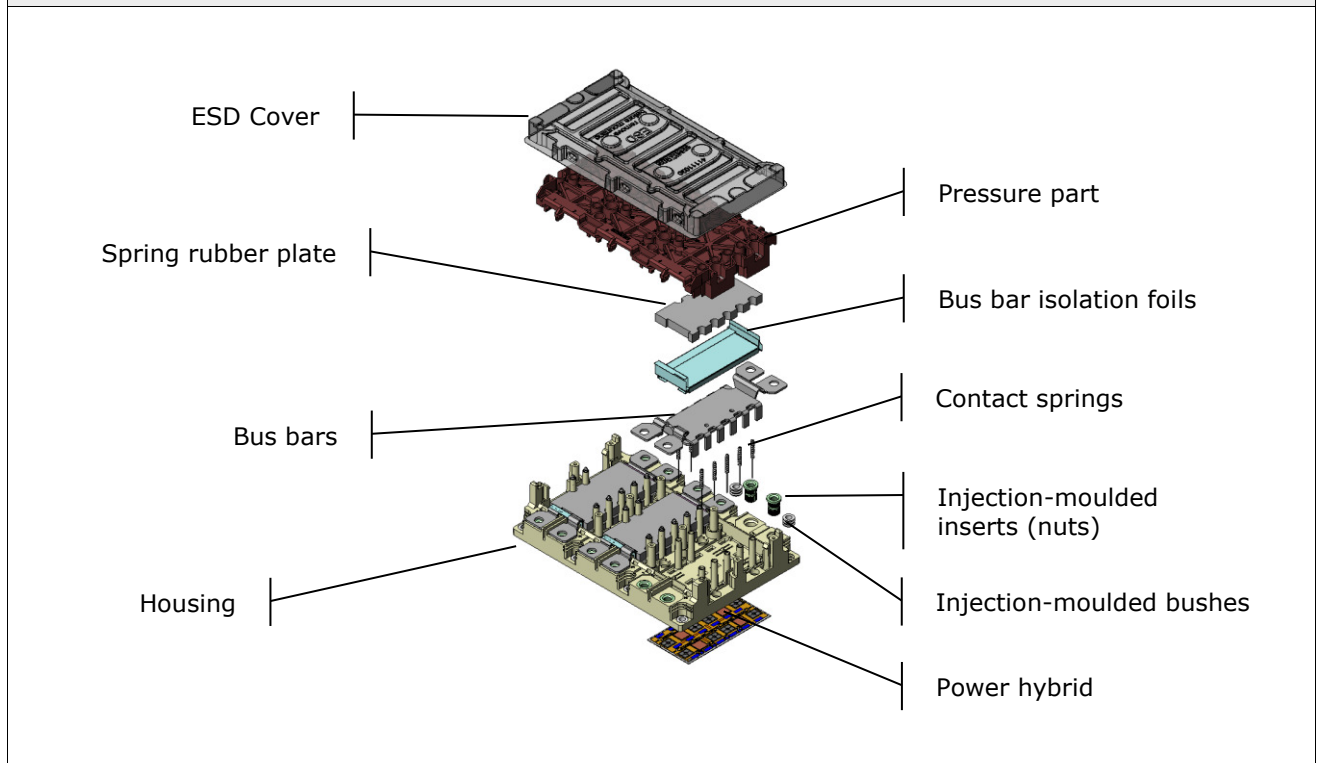

Note: SEMIKRON products are not subject to the electrical and electronic equipment law (ElektroG)> Nevertheless, SEMIKRON still produces the product family SKiM<sup>®</sup> in accordance with §5 of the ElektroG (prohibited substances) as well as article 4 of the directive 2002/95/EC of the European parliament (RoHS) on the restriction of the use of certain hazardous substances in electrical and electronic equipment. The ElektroG is the German legal equivalent of the European directive.

## 11. Packing Specifications

### 11.1 ESD COVER

Against electrostatic discharge (ESD) while transport, the SKiM is protected by an ESD cover. The ESD Cover is shown in Fig. 12-1.

**Fig. 11-1 SKiM with ESD Cover**

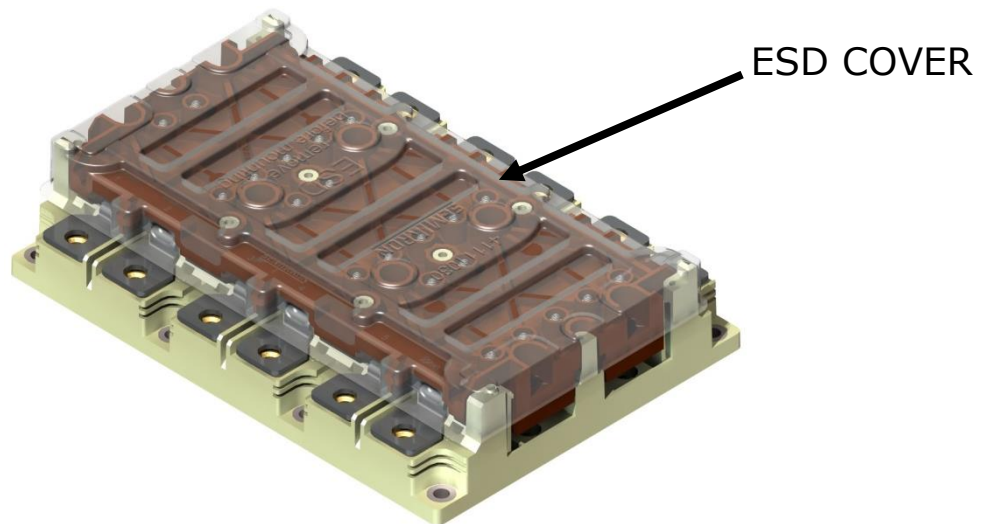

### 11.2 Packing Boxes

Standard packing boxes for SKiM modules:

**Fig. 11-2 Cardboard box with SKiM in transparent ESD tray, dimensions: 580 x 360 x 110 mm<sup>3</sup> (l x w x h)**



Quantities per package	SKiM 63	16 pcs
	SKiM 93	8 pcs
Weight per package	≤ 14 kg	
Bill of materials	Boxes:	Paper (card board)
	Trays:	ASK-PET/56 (not electrically chargeable)

### 11.3 Marking of Packing Boxes

All SKiM packing boxes contain a sticker label.

This label is placed on the packing box as shown in **Fig. 11-2**:

**Fig. 11-2: Location of label on SKiM packing boxes**



The label contains the following items (see Fig. 11-3)



- |          |                       |   |
|----------|-----------------------|---|
| <b>1</b> | SEMIKRON Logo         |   |
| <b>2</b> | "Dat. Cd:"            | Date code – 5 digits: YYMML (L=Lot of same type per week)<br>Suffix "R" stands for "RoHS conform"   |
| <b>3</b> | "Menge:"              | Quantity of SKiM modules inside the box – also as bar code  |
| <b>4</b> | SKiM Type Designation |   |
| <b>5</b> | "Au.-Nr :"            | Order confirmation number / Item number on order confirmation   |
| <b>6</b> | "Id.-Nr:"             | SEMIKRON part number – also as bar code   |
| <b>7</b> | ESD sign              | SKiM IGBT modules are sensitive to electrostatic discharges. Always ensure the environment is ESD proof before removing the ESD packaging and handling the modules. |

Bar code according to

- Standard: ECC 200
- Format: 19/9

## 12. Type Designation System

<b>1</b>	<b>2</b>	<b>3</b>	<b>4</b>	<b>5</b>	<b>6</b>	<b>7</b>
SKiM	40	6	GD	06	6	HD

**1** SKiM: Product name

**2** Nominal chip current  $I_{C,nom} / 10$

**3** Housing size

6	=	SKiM 63
9	=	SKiM 93

**4** Circuit specifications (examples)

GB	=	IGBT half bridge
GAL	=	IGBT low side chopper
GAR	=	IGBT high side chopper
GD	=	3 ~ IGBT inverter, "six pack"

**5** Voltage class

06	=	600 V
07	=	650 V
12	=	1200 V
17	=	1700 V

**6** IGBT chip technology

F4	=	Trench IGBT 4 (1200 V) Fast
E4	=	Trench IGBT 4 (1200 V) Medium Power

**7** Appendix (optional)

HD	=	CAL HD Diode
v <sub>1</sub> , v <sub>2</sub> ,...	=	Exclusive, customised special version

### 13. Figure Captions in the Datasheets

- Fig. 1** Collector current  $I_C$  as a function of the collector-emitter voltage  $V_{CE}$  (typical output characteristics) for  $T_j = 25\text{ °C}$  and  $T_j = 125\text{ °C}$ , Parameter: Gate-emitter voltage  $V_{GE}$ ; Values at terminal level, inclusive  $R_{CC'} + EE'$
- Fig. 2** Maximum rated continuous DC collector current  $I_C$  as a function of the case temperature  $T_{case}$ , terminal current  $I_{Cmax} = 600\text{ A}$  @  $T_{Terminal} = 100\text{ °C}$
- Fig. 3** Typical turn-on and turn-off energy dissipation  $E_{on}$  and  $E_{off}$  of an IGBT element and turn-off energy dissipation  $E_{rr}$  of a freewheeling diode as a function of the continuous collector current  $I_C$  for inductive load
- Fig. 4** Typical turn-on and turn-off energy dissipation  $E_{on}$  and  $E_{off}$  of an IGBT element and turn-off energy dissipation  $E_{rr}$  of a freewheeling diode as a function of the gate series resistance  $R_G$  for inductive load
- Fig. 5** Typical transfer characteristic: continuous collector current  $I_C$  as a function of the gate-emitter voltage  $V_{GE}$ ; Values at terminal level, inclusive  $R_{CC'} + EE'$
- Fig. 6** Typical gate charge characteristic: gate-emitter voltage  $V_{GE}$  as a function of the gate charge  $Q_G$
- Fig. 7** Typical IGBT switching times  $t_{don}$ ,  $t_r$ ,  $t_{doff}$  and  $t_f$  as a function of the continuous collector current  $I_C$  for inductive load and fixed gate series resistance  $R_G$  for  $T_j = 125\text{ °C}$
- Fig. 8** Typical IGBT switching times  $t_{don}$ ,  $t_r$ ,  $t_{doff}$  and  $t_f$  as a function of the gate series resistance  $R_G$  for inductive load and fixed collector current  $I_C$  for  $T_j = 125\text{ °C}$
- Fig. 9** Transient thermal impedance  $Z_{th(j-c)}$  of the IGBT element and the diode element as single pulse expired following an abrupt change in power dissipation
- Fig. 10** Typical forward characteristics of the inverse diode (typical and maximum values) for  $T_j = 25\text{ °C}$  and  $T_j = 125\text{ °C}$
- Fig. 11** Typical peak reverse recovery current  $I_{RRM}$  of the inverse diode as a function of the fall rate  $di_F/dt$  of the forward current with corresponding gate series resistance  $R_G$  of the IGBT during turn-on
- Fig. 12** Typical recovery charge  $Q_{rr}$  of the inverse diode as a function of the fall rate  $di_F/dt$  of the forward current (Parameters: forward current  $I_F$  and gate series resistance  $R_G$  of the IGBT during turn-on)

## 14. Disclaimer

SEMIKRON reserves the right to make changes without further notice herein to improve reliability, function or design. Information furnished in this document is believed to be accurate and reliable. However, no representation or warranty is given and no liability is assumed with respect to the accuracy or use of such information, including without limitation, warranties of non-infringement of intellectual property rights of any third party. SEMIKRON does not assume any liability arising out of the application or use of any product or circuit described herein. Furthermore, this technical information may not be considered as an assurance of component characteristics. No warranty or guarantee expressed or implied is made regarding delivery, performance or suitability. This document supersedes and replaces all information previously supplied and may be superseded by updates without further notice.

SEMIKRON products are not authorized for use in life support appliances and systems without the express written approval by SEMIKRON.

SEMIKRON INTERNATIONAL GmbH  
P.O. Box 820251 • 90253 Nuremberg • Germany  
Tel: +49 911-65 59-234 • Fax: +49 911-65 59-262

sales.skd@semikron.com • www.semikron.com

