

Technical Explanation  
**SKYPER®**  
**12 PF**

Revision:	07
Issue date:	2021-08-06
Prepared by:	A. Darmanandana, N. Hofstötter
Reviewed by:	F. Breite, A. Schiller
Approved by:	B. Eichler

Keyword: IGBT Driver, SKYPER, Press-fit, SEMiX press-fit

1. Introduction.....	2
2. Driver interface .....	3
2.1 Controller interface.....	3
2.1.1 SEMIKRON interface – 14P primary side pinning – L50666xx .....	3
2.1.2 Second source compatible interface – 20P primary side pinning – L50669xx.....	4
3. Protection features .....	6
3.1 Failure management.....	6
3.2 Adjustable dead time generation (Interlock TOP / BOT ) .....	6
3.3 Short pulse suppression (SPS) .....	6
3.4 SoftOff.....	6
3.5 Dynamic short circuit protection by $V_{CE}$ -monitoring (DSCP) .....	7
3.6 Over temperature lockout .....	7
4. Environmental Conditions .....	9

## 1. Introduction

The SKYPER® 12 PF drivers family are dedicated for SEMIX press-fit and EconoDUAL press-fit modules. The half bridge driver can be mounted directly onto 17mm press-fit DUAL modules. With 30% fewer components than available plug & play solutions, the driver achieves a MTBF (Mean Time Between Failures as per SN 29500) rate of 7.5 million hours at full load.

With the 1W power supply per channel the SKYPER® 12 PF can drive semiconductors of up to 600 Ampere and 1700V rating. For further details and precautions please read carefully this document.

**Figure 1: SKYPER® 12 PF**

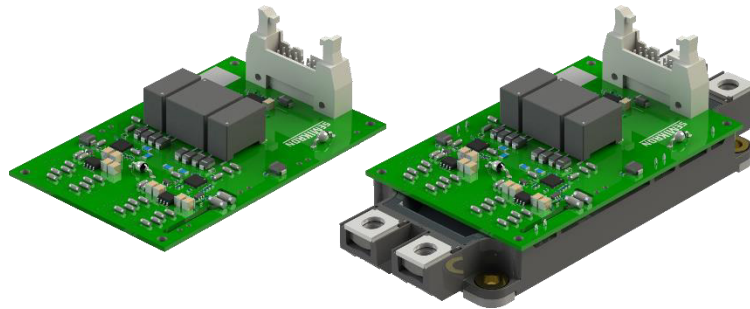

- Fits to 1200V & 1700V modules
- Drives EconoDUAL and SEMiX press-fit modules
- Qualified Safe Operating Area ensures best performance
- Safe short circuit handling over the entire temperature range
- Available with SEMIKRON and second source compatible interface
- Robust rectangle signal transmission
- Two output channels
- Highest noise immunity with short pulse suppression and EMC robust interface
- Insulated over temperature trip on secondary side
- Under voltage lockout (UVLO) employed on primary and secondary side
- Dynamic Short Circuit Protection (DSCP) by VCE monitoring and direct SoftOff
- Integrated isolated power supply for the secondary side
- 1W output power per channel
- Up to 8  $\mu\text{C}$  gate charge
- MTBF rate > 7.5 Million hours

**Figure 2: SKYPER® 12 PF | Block Diagram**

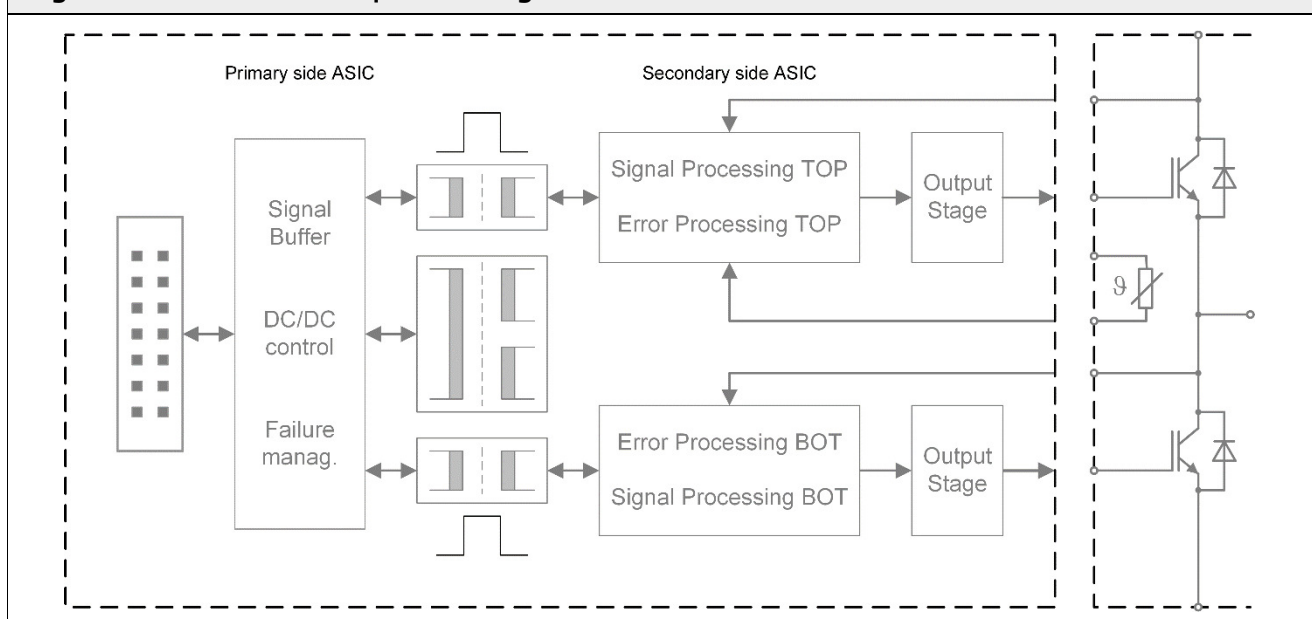

## 2. Driver interface

### 2.1 Controller interface

#### 2.1.1 SEMIKRON interface – 14P primary side pinning – L5066xx

**Figure 3: Connector X10 (Harting DIN 41651 – 14 P)**

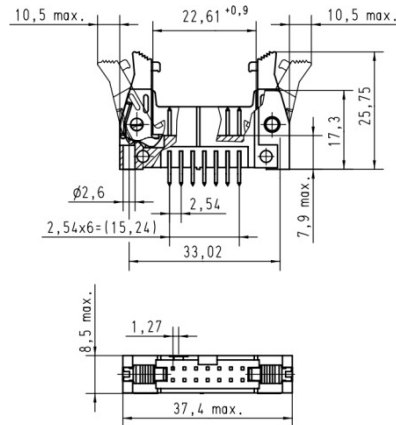

Product information of suitable female connectors and distributor contact information is available at e.g. <http://www.harting.com> (part number 09 18 514 7 904).

**Table 1: SKYPER® 12 PF | Interface**

Pin	Signal	Function	Specification
X10:01	reserved		To be connected to ground
X10:02	BOT_IN	Switching signal input (BOT)	15V logic; 33kΩ/1nF (pull-down) LOW = BOT switch off HIGH = BOT switch on
X10:03	nERR_OUT	Error output	Open Collector output; max. 18V/15mA (external pull-up resistor needed) LOW = Error HIGH = No error
X10:04	TOP_IN	Switching signal input (TOP)	15V logic; 33kΩ/1nF (pull-down) LOW = TOP switch off HIGH = TOP switch on
X10:05	nERR_IN	Error input	15V logic inverted; 150kΩ/10nF (pull-up) LOW = External error HIGH = No external error
X10:06	reserved		To be connected to ground
X10:07	reserved		To be connected to ground
X10:08	PWR_VS	Driver power supply	Stabilised +15V ±4%
X10:09	PWR_VS	Driver power supply	Stabilised +15V ±4%
X10:10	PWR_GND	Ground potential for power supply and digital signals	To be connected to ground

Pin	Signal	Function	Specification
X10:11	PWR_GND	Ground potential for power supply and digital signals	To be connected to ground
X10:12	reserved		To be connected to ground
X10:13	reserved		To be connected to ground
X10:14	reserved		To be connected to ground

### 2.1.2 Second source compatible interface – 20P primary side pinning – L50669xx

**Figure 4: Connector X10 (Harting DIN 41651 – 20 P)**

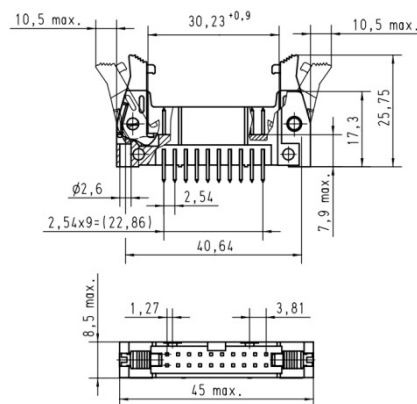

Product information of suitable female connectors and distributor contact information is available at e.g. <http://www.harting.com> (part number 09 18 520 7 904).

**Table 2: SKYPER® 12 PF | Interface**

Pin	Signal	Function	Specification
X10:01	reserved		Open pin
X10:02	PWR_GND	Ground potential for power supply and digital signals	To be connected to ground
X10:03	reserved		Open pin
X10:04	PWR_GND	Ground potential for power supply and digital signals	To be connected to ground
X10:05	PWR_VS	Driver power supply	Stabilised +15V ±4%
X10:06	PWR_GND	Ground potential for power supply and digital signals	To be connected to ground
X10:07	nERR_IN	Error input	15V logic inverted; 150kΩ/10nF (pull-up) LOW = External error HIGH = No external error

Pin	Signal	Function	Specification
X10:08	PWR_GND	Ground potential for power supply and digital signals	To be connected to ground
X10:09	nERR_OUT	Error output	Open Collector output; max. 18V/15mA (external pull-up resistor needed) LOW = Error HIGH = No error
X10:10	PWR_GND	Ground potential for power supply and digital signals	To be connected to ground
X10:11	TOP_IN	Switching signal input (TOP)	15V logic; 33kΩ/1nF (pull-down) LOW = TOP switch off HIGH = TOP switch on
X10:12	PWR_GND	Ground potential for power supply and digital signals	To be connected to ground
X10:13	nERR_OUT	Error output	Open collector output; max. 18V/15mA (external pull-up resistor needed) LOW = Error HIGH = No error
X10:14	PWR_GND	Ground potential for power supply and digital signals	To be connected to ground
X10:15	BOT_IN	Switching signal input (BOT)	15V logic; 33kΩ/1nF (pull-down) LOW = BOT switch off HIGH = BOT switch on
X10:16	PWR_GND	Ground potential for power supply and digital signals	To be connected to ground
X10:17	reserved		Open pin
X10:18	PWR_GND	Ground potential for power supply and digital signals	To be connected to ground
X10:19	reserved		Open pin
X10:20	PWR_GND	Ground potential for power supply and digital signals	To be connected to ground

### 3. Protection features

#### 3.1 Failure management

The SKYPER® 12 PF detects under voltages on primary and secondary side, short circuit and over temperature as fault conditions. Any error detected will force the output nERR\_OUT to low level. The driver's output stages will be set to low level. The input side switching signals of the driver will be ignored in this condition. Both input signals have to be set to low level for at least 9µs to reset the nERR\_OUT and to resume normal operation.

The following errors are indicated by the fault output

- Under supply voltage primary side
- Under supply voltage secondary side
- Short circuit with SoftOff
- Over temperature lockout

#### 3.2 Adjustable dead time generation (Interlock TOP / BOT )

The internal dead time control of the SKYPER® 12 PF is set to 2µs. The dead time circuit prevents, that both TOP and BOT semiconductors of the same half bridge can be erroneously activated simultaneously (arm shoot through) for this predefined minimum time, which for the final application might nevertheless not be enough. This minimum dead time is realised in the mixed signal ASIC and it is not added to a dead time provided by the controller that might generate deadtimes higher than the minimum one depending on the application. The highest dead time, e.g. either the internally generated one or the µC generated one will dominate.

Example:

<b>Table 3: SKYPER® 12 PF   Dead time generation</b>			
	<b>Controller dead time</b>	<b>SKYPER dead time</b>	<b>Total dead time</b>
Controller > driver	4µs	2µs	4µs
Controller < driver	1µs	2µs	2µs
Controller no dead time	No dead time	2µs	2µs

It is possible to control the driver with one switching signal and its inverted signal if the provided internal dead time of the SKYPER® 12 PF is sufficient for the application. No error signal will be generated when signals are overlapped.

#### 3.3 Short pulse suppression (SPS)

The SKYPER's driver circuit suppresses short turn-on and off-pulses of incoming signals. This way the semiconductors are protected against spurious noise as they can occur due to bursts on the signal lines. Short or high noise pulses do not affect the driver on the controller side. The digital SPS is set to 390ns.

#### 3.4 SoftOff

In in case of a detection of a secondary side error like a short circuit, the SoftOff feature increases the resistance in series with  $R_{G(off)}$  and, hence, reduces the turn-off speed of the semiconductor. The reduced di/dt reduces the voltage spike across the IGBT's Collector and Emitter terminals in this short circuit case.

### 3.5 Dynamic short circuit protection by $V_{CE}$ -monitoring (DSCP)

The DSCP monitors the Collector-Emitter voltage  $V_{CE}$  of the semiconductor during its on-state. During the transient process at turn-on of the semiconductor, typically a higher value of the  $V_{CE}$  is effective than in steady state, e.g. after the semiconductor is fully saturated. The dynamic short circuit protection circuitry as shown in bellows figure creates internally a reference signal as time varying  $V_{CE}$  detection threshold that widely follows a typical saturation behavior of a bipolar semiconductor and, hence, provides a time depending short circuit protection level.

**Figure 5: SKYPER® 12 PF | Reference voltage ( $V_{CEref}$ ) characteristic**

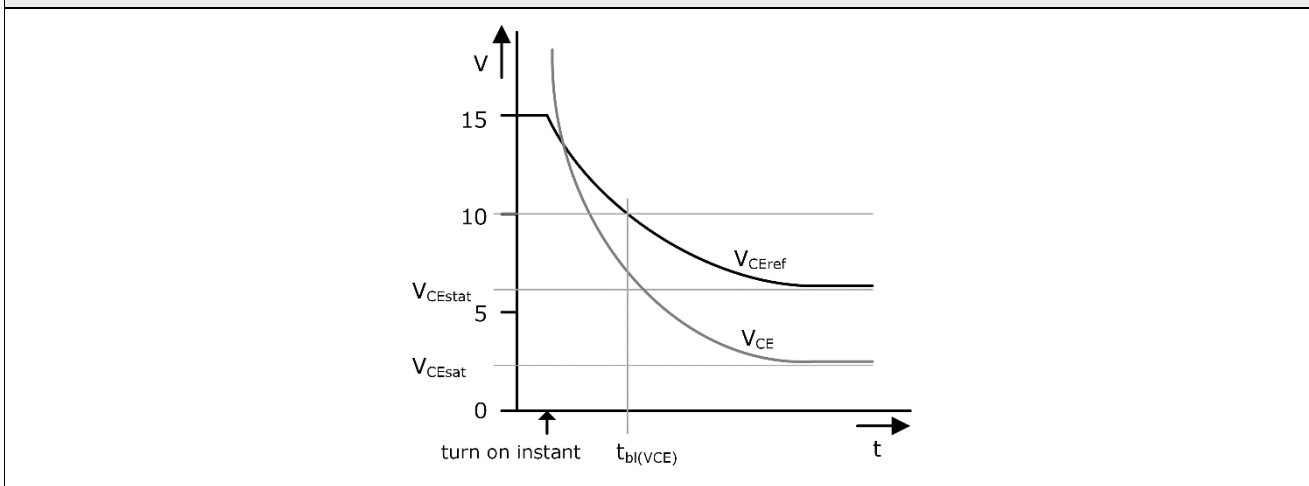

Figure 5 indicates that this short circuit protection operates in conjunction with the blanking time  $t_{bl(V_{CE})}$  which blanks the high saturation voltages in the very early stage of the semiconductor's turn-on stage. After this blanking time  $t_{bl(V_{CE})}$  has passed, the  $V_{CE}$ -monitoring will be triggered as soon as  $V_{CE} > V_{CEref}$  and will turn off the semiconductor.

### 3.6 Over temperature lockout

The SKYPER® 12 PF driver offers an over temperature lockout feature which sets both driver output stages to  $V_{G(off)}$  and ignores the switching signals on primary side as long as the electrical resistance of the applied temperature sensor is less than the specified over temperature lockout resistance value  $R_{OTLO}$  (the value of  $R_{OTLO}$  is given in the corresponding datasheet). In addition to the locked outputs, the driver's primary side reports an error at the nERR\_OUT pin(s). This status is latched as long as the resistance of the temperature sensor is less than  $R_{OTLO}$  and both switching signals have not been set to low state for at least 9 $\mu$ s initiating the reset of the SKYPER® 12 PF and allow resuming to normal operation. The over temperature lockout feature is designed for temperature sensors with an NTC resistor characteristic.

The lockout feature can be deactivated by removal of both populated zero-ohm jumpers, shown in Figure 6. If both jumpers are removed the module's temperature sensor's resistance can be acquired directly via the temperature sensor pads, also shown in Figure 6. The pads are foreseen for an industrial standard two pin terminal connector with 3.96mm pitch.

For proper and safe monitoring of the module's temperature sensor the corresponding datasheets and technical documentation must be read carefully. Especially the part describing the insulation of the temperature sensor needs an expert's assessment for safety reasons. It also has to be taken into account that populating a connector on the PCB, e.g. for a direct evaluation of the temperature sensor's resistance, may affect the driver's clearance and creepage distances.

**Figure 6: SKYPER® 12 PF | Over temperature lockout zero-ohm jumper**

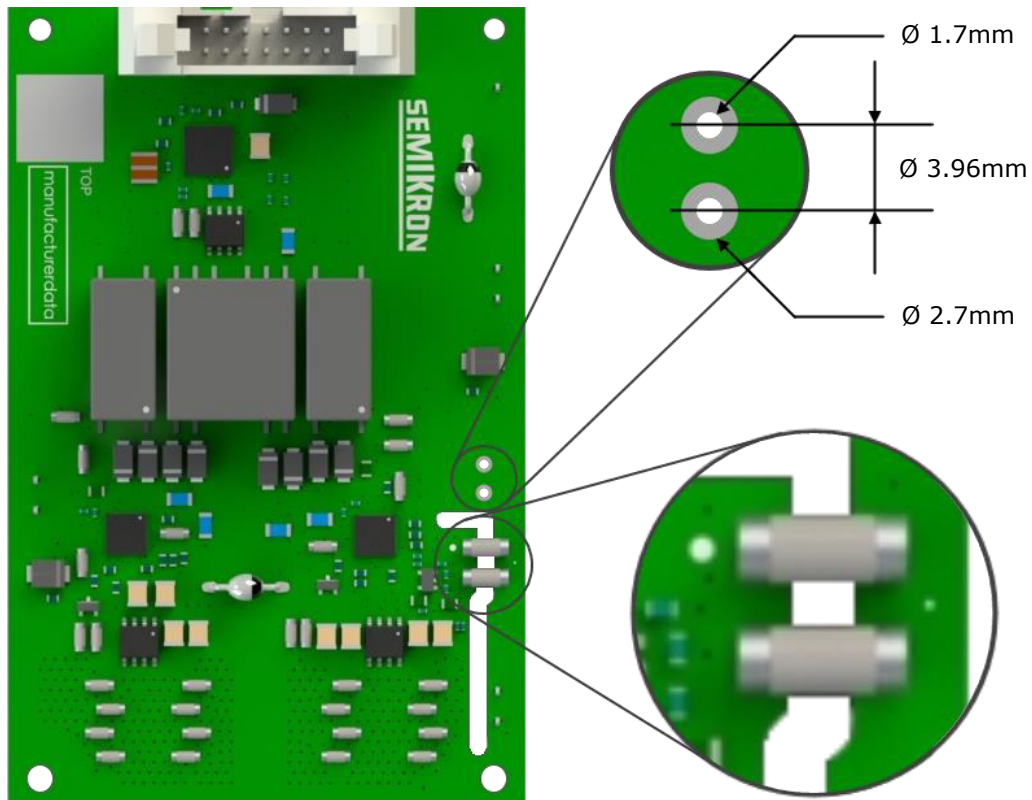

#### 4. Environmental Conditions

<b>Table 4: SKYPER® 12 PF   Environmental Conditions</b>		
<b>Insulation parameters</b>	<b>Rating</b>	<b>Norm / Standard</b>
Grid voltage	600V (480V by definition)	IEC 61800-5-1
Pollution Degree	PD II	IEC 61800-5-1
Maximum altitude	2000 meter above sea	IEC 61800-5-1
Overvoltage category	OVC III	IEC 61800-5-1
Dielectric voltage withstand	4000V AC rms, 60s	IEC 61800-5-1
Impulse withstand voltage	8kV Cat. III	IEC 60664-1
Partial discharge	1.86kV/1.49kV	IEC 61800-5-1
Creepage/clearance distance, primary/secondary side	≥12.2mm/≥12.2mm (CTI≥175)	IEC 61800-5-1
Creepage/clearance distance, secondary/secondary side	≥6.1mm/≥6.1mm (CTI≥175)	IEC 61800-5-1
Creepage/clearance distance, temperature sensor/secondary side	≥6.1mm/≥3.1mm (CTI≥175)	IEC 61800-5-1
<b>Climate</b>	<b>Rating</b>	<b>Norm / Standard</b>
Climate class	3K3	IEC 60721-3-3
<b>Environmental conditions</b>	<b>Rating</b>	<b>Norm / Standard</b>
Operating temperature	-40... +85 °C	
Storage temperature	-40... +85 °C	
Flammability	Heavy flammable materials only	UL94 V0
Thermal Cycling	500 cycles a 1h -40°C - 85°C	IEC 60068-2-14
		RoHS / WEEE / China RoHS

<b>EMC Condition</b>	<b>Rating</b>	<b>Norm / Standard</b>
ESD	6 kV contact discharge / 8 kV air discharge	IEC 61000-4-2 IEC 61800-3
Burst	≥ 2kV for signal line ≥ 4kV for AC lines	IEC 61000-4-4 IEC 61800-3
Immunity against external interference	≥ 30V/m 80MHz – 1000 MHz	IEC 61000-4-3 IEC 61800-3
Immunity against conducted interference	≥ 20V 150kHz – 80MHz	IEC 61000-4-6 IEC 61800-3
<b>Shock Vibration</b>	<b>Rating</b>	<b>Norm / Standard</b>
Vibration	Sinusoidal 20Hz ... 500Hz, 5g, 2h per axis Random 10Hz ... 2000Hz, 1g, 2h per axis	IEC 60068-2-6
Shock	200 shocks (6 axis), 20g, 11ms	IEC 60068-2-27

Figure 1: SKYPER® 12 PF .....	2
Figure 2: SKYPER® 12 PF   Block Diagram .....	2
Figure 3: Connector X10 (Harting DIN 41651 – 14 P) .....	3
Figure 4: Connector X10 (Harting DIN 41651 – 20 P) .....	4
Figure 5: SKYPER® 12 PF   Reference voltage ( $V_{CEref}$ ) characteristic.....	7
Figure 6: SKYPER® 12 PF   Over temperature lockout zero-ohm jumper .....	8
Table 1: SKYPER® 12 PF   Interface .....	3
Table 2: SKYPER® 12 PF   Interface .....	4
Table 3: SKYPER® 12 PF   Dead time generation .....	6
Table 4: SKYPER® 12 PF   Environmental Conditions .....	9



## Symbols and Terms

Letter Symbol	Term
ASIC	Application Specific Integrated Circuit
DSCP	Dynamic short circuit protection
IGBT	Insulated Gate Bipolar Transistor
MTBF	Mean time between failures
NTC	Negative temperature coefficient
$R_{G(off)}$	Turn-off gate resistor
$R_{OTLO}$	Threshold value for over temperature lookout
SPS	Short pulse suppression
$t_{bl(V_{CE})}$	Blanking time for $V_{CE}$ -monitoring
UVLO	Under voltage lockout
$V_{CE}$	Collector-emitter voltage (IGBT)
$V_{CEref}$	Reference voltage for $V_{CE}$ -monitoring
$V_{CEsat}$	Collector-emitter saturation voltage
$V_{CEstat}$	Static threshold voltage for collector-emitter voltage monitoring
$V_{G(off)}$	Turn-off gate voltage level

A detailed explanation of the terms and symbols can be found in the "Application Manual Power Semiconductors" [2]

## References

- [1] [www.SEMİKRON.com](http://www.SEMİKRON.com)  
 [2] A. Wintrich, U. Nicolai, W. Tursky, T. Reimann, "Application Manual Power Semiconductors", 2nd edition, ISLE Verlag 2015, ISBN 978-3-938843-83-3

## IMPORTANT INFORMATION AND WARNINGS

The information in this document may not be considered as guarantee or assurance of product characteristics ("Beschaffenhheitsgarantie"). This document describes only the usual characteristics of products to be expected in typical applications, which may still vary depending on the specific application. Therefore, products must be tested for the respective application in advance. Application adjustments may be necessary. The user of SEMİKRON products is responsible for the safety of their applications embedding SEMİKRON products and must take adequate safety measures to prevent the applications from causing a physical injury, fire or other problem if any of SEMİKRON products become faulty. The user is responsible to make sure that the application design is compliant with all applicable laws, regulations, norms and standards. Except as otherwise explicitly approved by SEMİKRON in a written document signed by authorized representatives of SEMİKRON, SEMİKRON products may not be used in any applications where a failure of the product or any consequences of the use thereof can reasonably be expected to result in personal injury. No representation or warranty is given and no liability is assumed with respect to the accuracy, completeness and/or use of any information herein, including without limitation, warranties of non-infringement of intellectual property rights of any third party. SEMİKRON does not assume any liability arising out of the applications or use of any product; neither does it convey any license under its patent rights, copyrights, trade secrets or other intellectual property rights, nor the rights of others. SEMİKRON makes no representation or warranty of non-infringement or alleged non-infringement of intellectual property rights of any third party which may arise from applications. This document supersedes and replaces all information previously supplied and may be superseded by updates. SEMİKRON reserves the right to make changes.

SEMİKRON INTERNATIONAL GmbH  
 Sigmundstrasse 200, 90431 Nuremberg, Germany  
 Tel: +49 911 6559 6663, Fax: +49 911 6559 262  
[sales@semikron.com](mailto:sales@semikron.com), [www.semikron.com](http://www.semikron.com)