

SKiIP 39AHB16V3

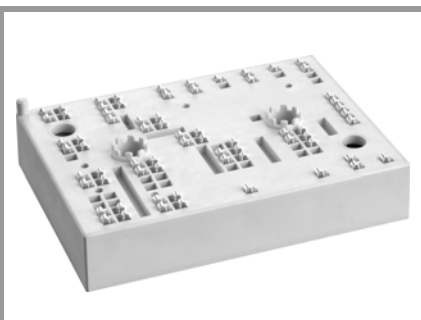

MiniSKiIP® 3

SKiIP 39AHB16V3

Features*

- Fast Trench IGBTs
- Robust and soft freewheeling diodes in CAL technology
- Highly reliable spring contacts for electrical connections
- UL recognised file no. E63532

Typical Applications

- Input bridge for inverter up to 45 kVA

Remarks

- V_{CEsat} , V_F = chip level value
- Case temp. limited to $T_C = 125^\circ\text{C}$ max. (for baseplateless modules $T_C = T_S$)
- product rel. results valid for $T_j \leq 150^\circ\text{C}$ (recomm. $T_{op} = -40 \dots +150^\circ\text{C}$)
- Thyristor 1 = T1-T3
- Diode 1 = D1
- Diode 2 = D2
- IGBT 1 = T4
- -B limited to $I_{t(RMS)}=80\text{A}$

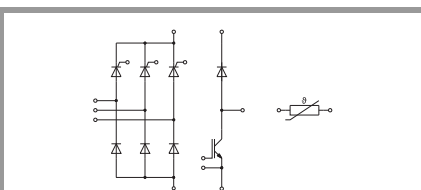

AHB

Absolute Maximum Ratings			
Symbol	Conditions	Values	Unit
Thyristor 1			
V_{RRM}	$T_j = 25^\circ\text{C}$	1600	V
$I_{T(AV)}$	$T_j = 130^\circ\text{C}$	86	A
	$T_s = 70^\circ\text{C}$ sin. 180°	110	A
I_{TSM}	10 ms, sin 180° , $T_j = 130^\circ\text{C}$	1170	A
i^2t	10 ms, sin 180° , $T_j = 130^\circ\text{C}$	6845	A^2s
T_j		-40 ... 130	$^\circ\text{C}$

Absolute Maximum Ratings				
Symbol	Conditions	Values	Unit	
Diode 1				
V_{RRM}	$T_j = 25^\circ\text{C}$	1600	V	
I_F	$\lambda_{paste}=0.8 \text{ W}/(\text{mK})$	$T_s = 25^\circ\text{C}$	176	A
	$T_j = 150^\circ\text{C}$	$T_s = 70^\circ\text{C}$	128	A
I_F	$\lambda_{paste}=2.5 \text{ W}/(\text{mK})$	$T_s = 25^\circ\text{C}$	215	A
	$T_j = 150^\circ\text{C}$	$T_s = 70^\circ\text{C}$	159	A
I_{FSM}	10 ms, sin 180° , $T_j = 150^\circ\text{C}$	1280	A	
i^2t	10 ms, sin 180° , $T_j = 150^\circ\text{C}$	8192	A^2s	
T_j		-40 ... 150	$^\circ\text{C}$	

Absolute Maximum Ratings				
Symbol	Conditions	Values	Unit	
Diode 2				
V_{RRM}	$T_j = 25^\circ\text{C}$	1200	V	
I_F	$\lambda_{paste}=0.8 \text{ W}/(\text{mK})$	$T_s = 25^\circ\text{C}$	204	A
	$T_j = 175^\circ\text{C}$	$T_s = 70^\circ\text{C}$	161	A
I_F	$\lambda_{paste}=2.5 \text{ W}/(\text{mK})$	$T_s = 25^\circ\text{C}$	260	A
	$T_j = 175^\circ\text{C}$	$T_s = 70^\circ\text{C}$	207	A
I_{FRM}		600	A	
I_{FSM}	10 ms	$T_j = 25^\circ\text{C}$	990	A
	sin 180°	$T_j = 150^\circ\text{C}$	990	A
T_j		-40 ... 175	$^\circ\text{C}$	

Absolute Maximum Ratings				
Symbol	Conditions	Values	Unit	
IGBT 1				
V_{CES}	$T_j = 25^\circ\text{C}$	1200	V	
I_C	$\lambda_{paste}=0.8 \text{ W}/(\text{mK})$	$T_s = 25^\circ\text{C}$	181	A
	$T_j = 175^\circ\text{C}$	$T_s = 70^\circ\text{C}$	147	A
I_C	$\lambda_{paste}=2.5 \text{ W}/(\text{mK})$	$T_s = 25^\circ\text{C}$	233	A
	$T_j = 175^\circ\text{C}$	$T_s = 70^\circ\text{C}$	190	A
I_{Cnom}		150	A	
I_{CRM}		450	A	
V_{GES}		-20 ... 20	V	
t_{psc}	$V_{CC} = 800 \text{ V}$ $V_{GE} \leq 15 \text{ V}$ $V_{CES} \leq 1200 \text{ V}$	$T_j = 150^\circ\text{C}$	10	μs
T_j		-40 ... 175	$^\circ\text{C}$	

SKiiP 39AHB16V3

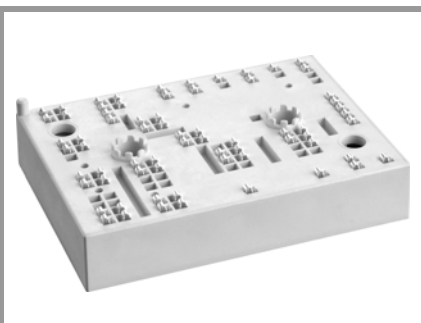

MiniSKiiP® 3

SKiiP 39AHB16V3

Features*

- Fast Trench IGBTs
- Robust and soft freewheeling diodes in CAL technology
- Highly reliable spring contacts for electrical connections
- UL recognised file no. E63532

Typical Applications

- Input bridge for inverter up to 45 kVA

Remarks

- V_{CEsat} , V_F = chip level value
- Case temp. limited to $T_C = 125^\circ\text{C}$ max. (for baseplateless modules $T_C = T_S$)
- product rel. results valid for $T_j \leq 150^\circ\text{C}$ (recomm. $T_{op} = -40 \dots +150^\circ\text{C}$)
- Thyristor 1 = T1-T3
- Diode 1 = D1
- Diode 2 = D2
- IGBT 1 = T4
- -B limited to $I_{T(RMS)}=80\text{A}$

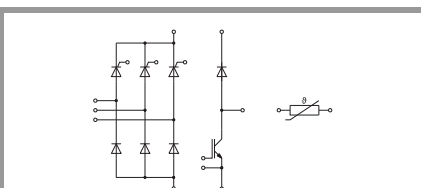

AHB

Absolute Maximum Ratings			
Symbol	Conditions	Values	Unit
Module			
$I_{T(RMS)}$	20 A per spring	160	A
T_{stg}	module without TIM	-40 ... 125	$^\circ\text{C}$
V_{isol}	AC sinus 50 Hz, $t = 1$ min	2500	V

Characteristics					
Symbol	Conditions	min.	typ.	max.	Unit
Thyristor 1					
V_T	$I_T = 110$ A chipllevel	$T_j = 25^\circ\text{C}$		1.26	V
		$T_j = 130^\circ\text{C}$		1.19	V
$V_{T(TO)}$	$T_j = 130^\circ\text{C}$, chipllevel			0.85	V
r_T	$T_j = 130^\circ\text{C}$, chipllevel			3.2	m Ω
V_{GT}	$T_j = 25^\circ\text{C}$	2			V
I_{GT}	$T_j = 25^\circ\text{C}$	100			mA
I_H	$T_j = 25^\circ\text{C}$	220			mA
I_L	$T_j = 25^\circ\text{C}$	550			mA
dv/dt_{cr}	$T_j = 130^\circ\text{C}$			1000	V/ μs
di/dt_{cr}	$T_j = 130^\circ\text{C}$			100	A/ μs
$R_{th(j-s)}$	per Thyristor, $\lambda_{paste}=0.8$ W/(mK), sin. 180 $^\circ$		0.46		K/W
$R_{th(j-s)}$	per Thyristor, $\lambda_{paste}=2.5$ W/(mK), sin. 180 $^\circ$		0.32		K/W

Characteristics					
Symbol	Conditions	min.	typ.	max.	Unit
Diode 1					
V_F	$I_F = 77$ A $V_{GE} = 0$ V chipllevel	$T_j = 25^\circ\text{C}$	1.00	1.21	V
		$T_j = 125^\circ\text{C}$	0.90	1.10	V
V_{F0}	chipllevel	$T_j = 25^\circ\text{C}$	0.88	0.98	V
		$T_j = 125^\circ\text{C}$	0.73	0.83	V
r_F	chipllevel	$T_j = 25^\circ\text{C}$	1.56	3.0	m Ω
		$T_j = 125^\circ\text{C}$	2.2	3.5	m Ω
I_R	$T_j = 145^\circ\text{C}$, V_{RRM}			1.1	mA
$R_{th(j-s)}$	per Diode, $\lambda_{paste}=0.8$ W/(mK)		0.5		K/W
$R_{th(j-s)}$	per Diode, $\lambda_{paste}=2.5$ W/(mK)		0.37		K/W

Characteristics					
Symbol	Conditions	min.	typ.	max.	Unit
Diode 2					
V_F	$I_F = 200$ A $V_{GE} = 0$ V chipllevel	$T_j = 25^\circ\text{C}$	1.77	2.09	V
		$T_j = 150^\circ\text{C}$	1.79	2.17	V
V_{F0}	chipllevel	$T_j = 25^\circ\text{C}$	1.19	1.40	V
		$T_j = 150^\circ\text{C}$	0.97	1.10	V
r_F	chipllevel	$T_j = 25^\circ\text{C}$	2.9	3.5	m Ω
		$T_j = 150^\circ\text{C}$	4.1	5.4	m Ω
I_{RRM}	$I_F = 150$ A $T_j = 150^\circ\text{C}$		286		A
Q_{rr}	$di/dt_{off} = 5900$ A/ μs $T_j = 150^\circ\text{C}$		25		μC
E_{rr}	$V_{GE} = -15$ V $V_{CC} = 600$ V $T_j = 150^\circ\text{C}$		10		mJ
$R_{th(j-s)}$	per Diode, $\lambda_{paste}=0.8$ W/(mK)		0.35		K/W
$R_{th(j-s)}$	per Diode, $\lambda_{paste}=2.5$ W/(mK)		0.24		K/W

SKiiP 39AHB16V3

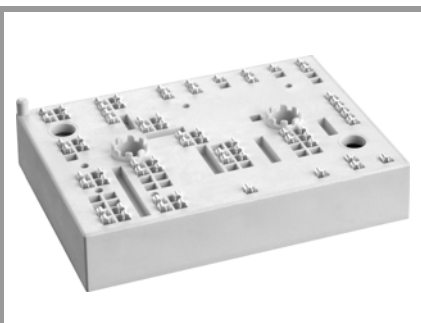

MiniSKiiP® 3

SKiiP 39AHB16V3

Features*

- Fast Trench IGBTs
- Robust and soft freewheeling diodes in CAL technology
- Highly reliable spring contacts for electrical connections
- UL recognised file no. E63532

Typical Applications

- Input bridge for inverter up to 45 kVA

Remarks

- V_{CEsat} , V_F = chip level value
- Case temp. limited to $T_C = 125^\circ\text{C}$ max. (for baseplateless modules $T_C = T_S$)
- product rel. results valid for $T_j \leq 150^\circ\text{C}$ (recomm. $T_{op} = -40 \dots +150^\circ\text{C}$)
- Thyristor 1 = T1-T3
- Diode 1 = D1
- Diode 2 = D2
- IGBT 1 = T4
- -B limited to $I_{t(RMS)}=80\text{A}$

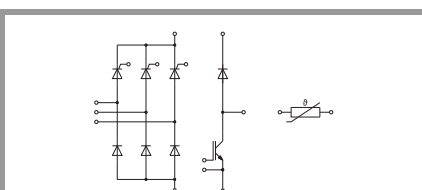

AHB

Characteristics						
Symbol	Conditions		min.	typ.	max.	Unit
IGBT 1						
$V_{CE(sat)}$	$I_C = 150\text{ A}$ $V_{GE} = 15\text{ V}$ chipllevel	$T_j = 25^\circ\text{C}$	1.85	2.10		V
		$T_j = 150^\circ\text{C}$	2.25	2.45		V
V_{CE0}	chipllevel	$T_j = 25^\circ\text{C}$	0.80	0.90		V
		$T_j = 150^\circ\text{C}$	0.70	0.80		V
r_{CE}	$V_{GE} = 15\text{ V}$ chipllevel	$T_j = 25^\circ\text{C}$	7.0	8.0		m Ω
		$T_j = 150^\circ\text{C}$	10	11		m Ω
$V_{GE(th)}$	$V_{GE} = V_{CE}, I_C = 6\text{ mA}$		5	5.8	6.5	V
I_{CES}	$V_{GE} = 0\text{ V}, V_{CE} = 1200\text{ V}, T_j = 25^\circ\text{C}$				1.5	mA
C_{ies}	$V_{CE} = 25\text{ V}$ $V_{GE} = 0\text{ V}$	$f = 1\text{ MHz}$		8.80		nF
C_{oes}		$f = 1\text{ MHz}$		0.58		nF
C_{res}		$f = 1\text{ MHz}$		0.47		nF
Q_G	$V_{GE} = -8\text{ V} \dots +15\text{ V}$			850		nC
R_{Gint}	$T_j = 25^\circ\text{C}$			5.0		Ω
$t_{d(on)}$	$V_{CC} = 600\text{ V}$ $I_C = 150\text{ A}$	$T_j = 150^\circ\text{C}$		114		ns
t_r	$V_{GE} = +15/-15\text{ V}$	$T_j = 150^\circ\text{C}$		30		ns
E_{on}	$R_{G on} = 0.5\ \Omega$	$T_j = 150^\circ\text{C}$		9		mJ
$t_{d(off)}$	$R_{G off} = 0\ \Omega$	$T_j = 150^\circ\text{C}$		357		ns
t_f	$di/dt_{on} = 5900\text{ A}/\mu\text{s}$ $di/dt_{off} = 1300\text{ A}/\mu\text{s}$	$T_j = 150^\circ\text{C}$		92		ns
E_{off}	$dv/dt = 4700\text{ V}/\mu\text{s}$ $L_s = 48\text{ nH}$	$T_j = 150^\circ\text{C}$		17		mJ
$R_{th(j-s)}$	per IGBT, $\lambda_{paste}=0.8\text{ W}/(\text{mK})$			0.28		K/W
$R_{th(j-s)}$	per IGBT, $\lambda_{paste}=2.5\text{ W}/(\text{mK})$			0.18		K/W

Characteristics						
Symbol	Conditions		min.	typ.	max.	Unit
Module						
M_s	to heat sink		2		2.5	Nm
w	weight			82		g

Characteristics						
Symbol	Conditions		min.	typ.	max.	Unit
Temperature Sensor						
R_{100}	$T_r=100^\circ\text{C}$ ($R_{25}=1000\ \Omega$)			1670 \pm 3%		Ω
$R_{(T)}$	$R_{(T)}=1000\ \Omega[1+A(T-25^\circ\text{C})+B(T-25^\circ\text{C})^2]$, $A = 7.635 \cdot 10^{-3} \text{ }^\circ\text{C}^{-1}$, $B = 1.731 \cdot 10^{-5} \text{ }^\circ\text{C}^{-2}$					

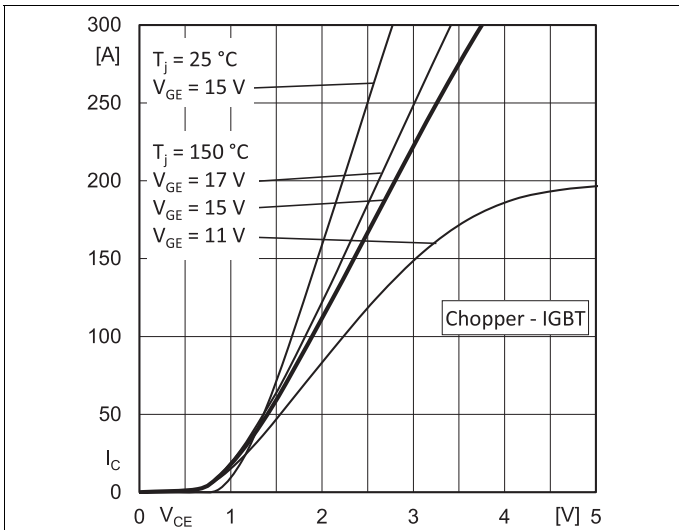

Fig. 1: Typ. output characteristic, inclusive $R_{CC'+EE'}$

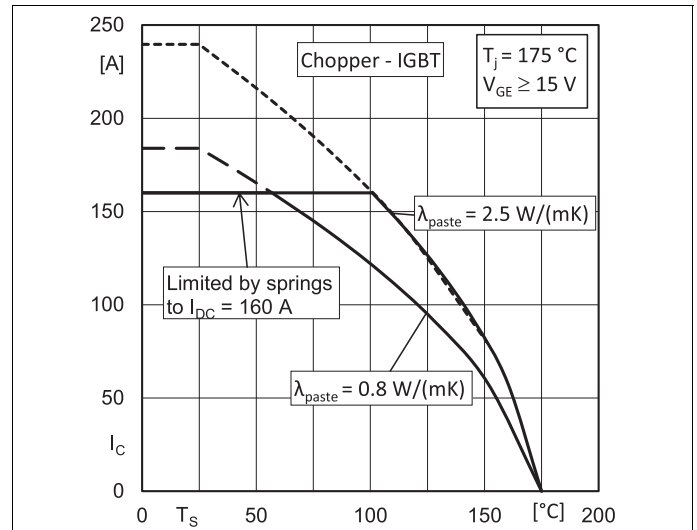

Fig. 2: Rated current vs. temperature $I_C = f(T_S)$

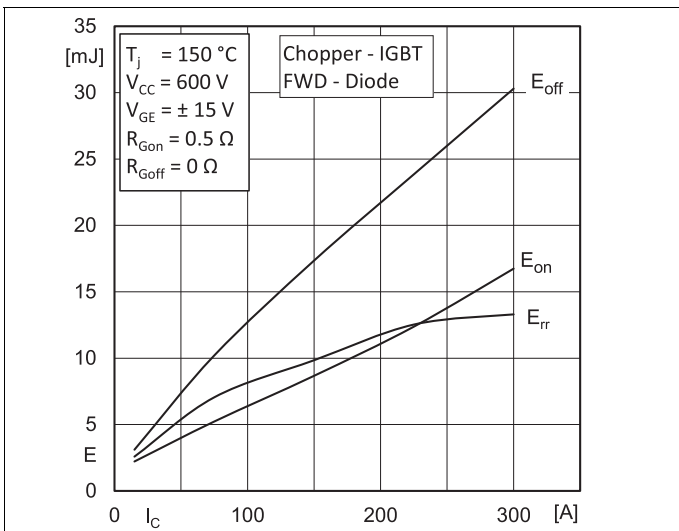

Fig. 3: Typ. turn-on /-off energy = $f(I_C)$

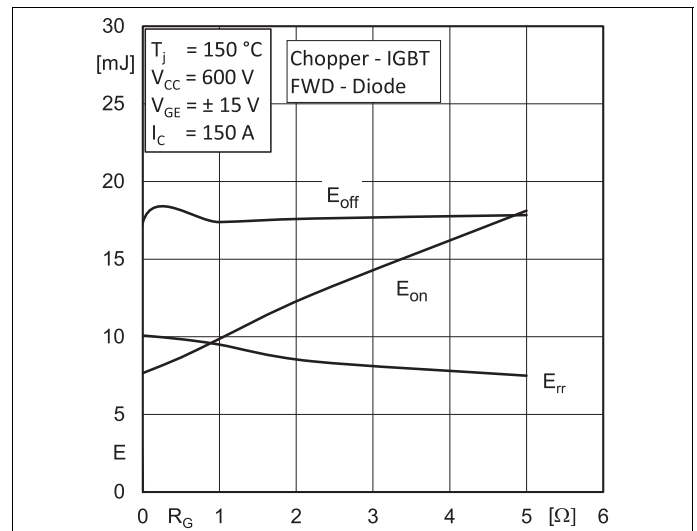

Fig. 4: Typ. turn-on /-off energy = $f(R_G)$

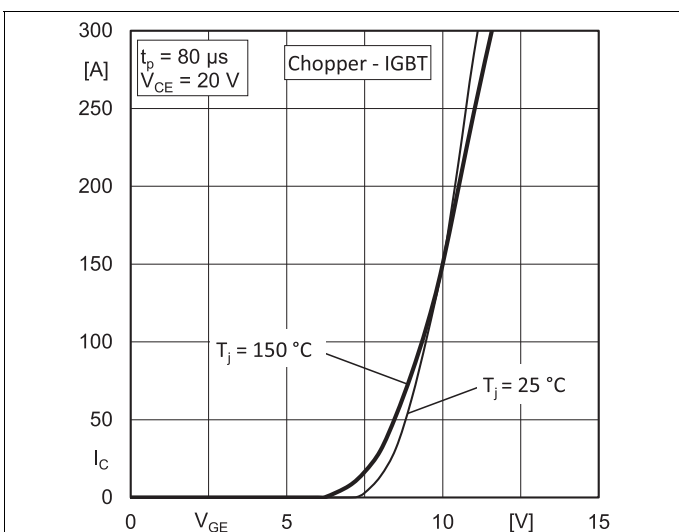

Fig. 5: Typ. transfer characteristic

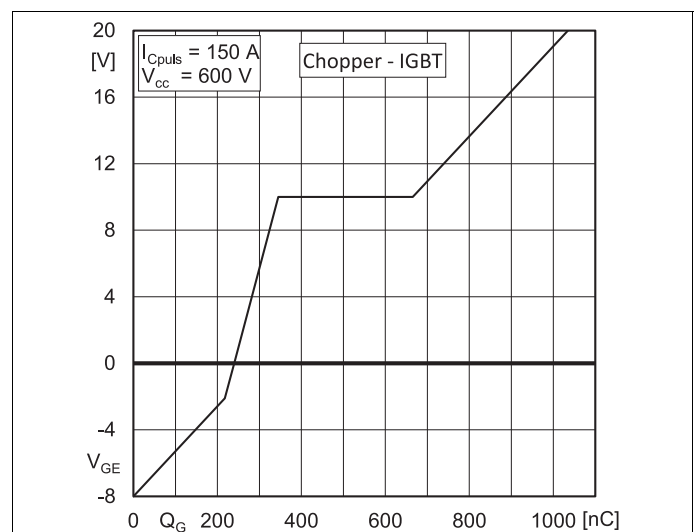

Fig. 6: Typ. gate charge characteristic

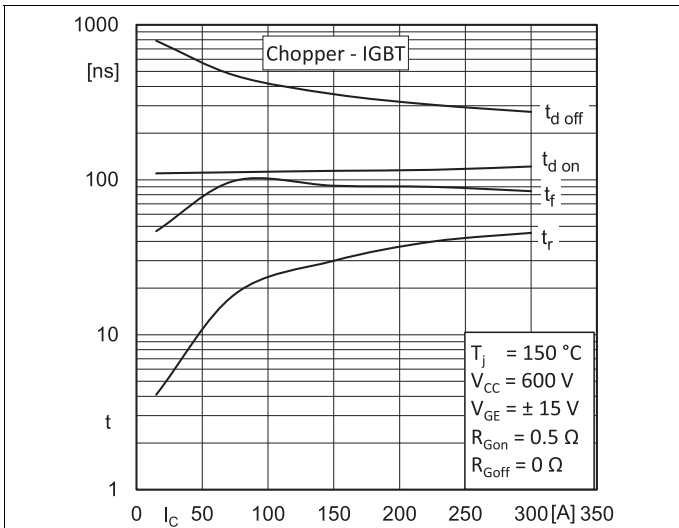

Fig. 7: Typ. switching times vs. I_C

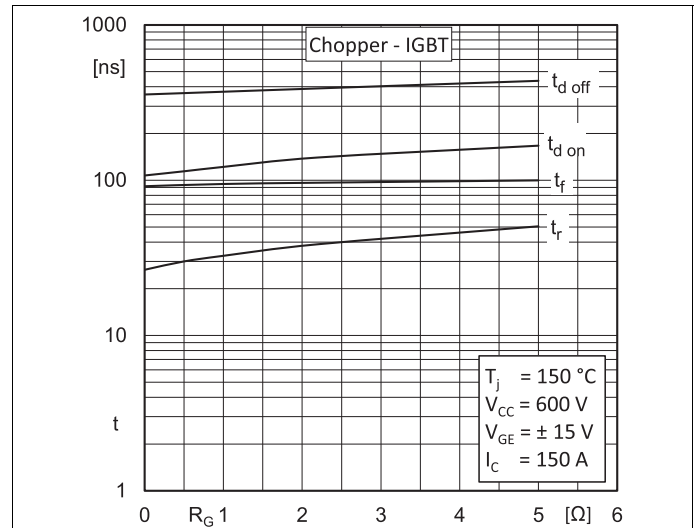

Fig. 8: Typ. switching times vs. gate resistor R_G

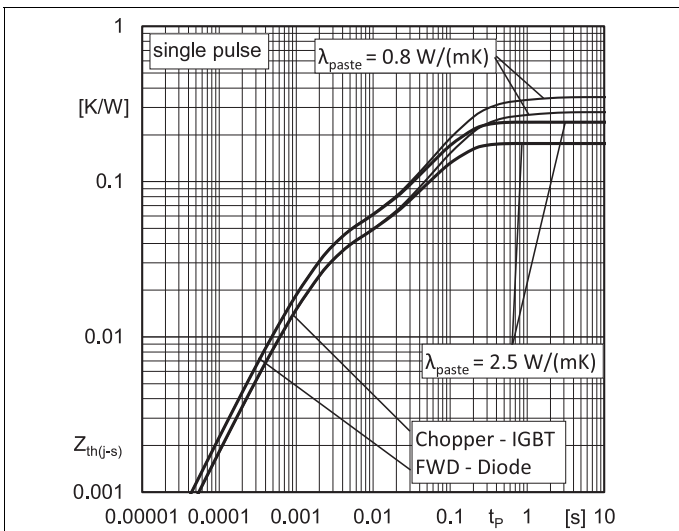

Fig. 9: Typ. transient thermal impedance

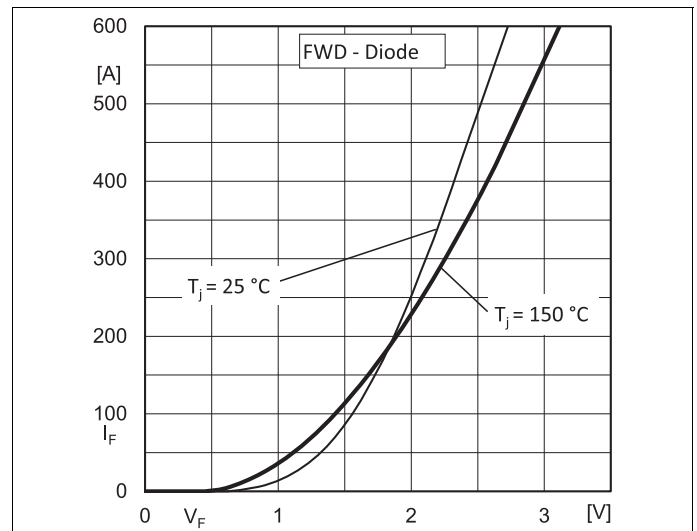

Fig. 10: Typ. CAL diode forward charact., incl. $R_{CC+EE'}$

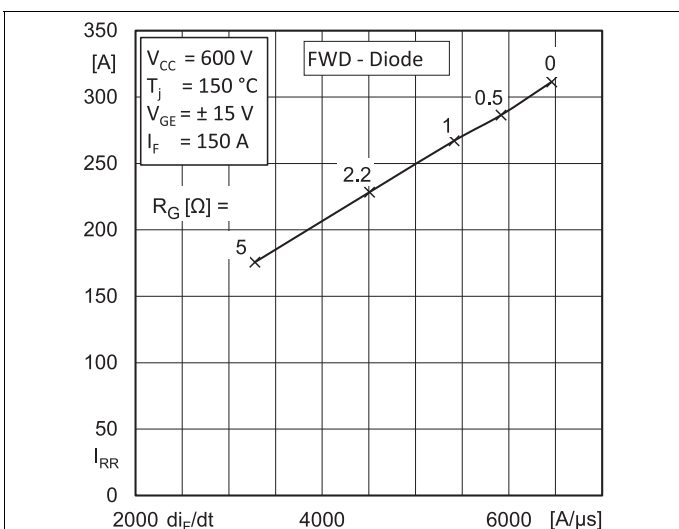

Fig. 11: Typ. CAL diode peak reverse recovery current

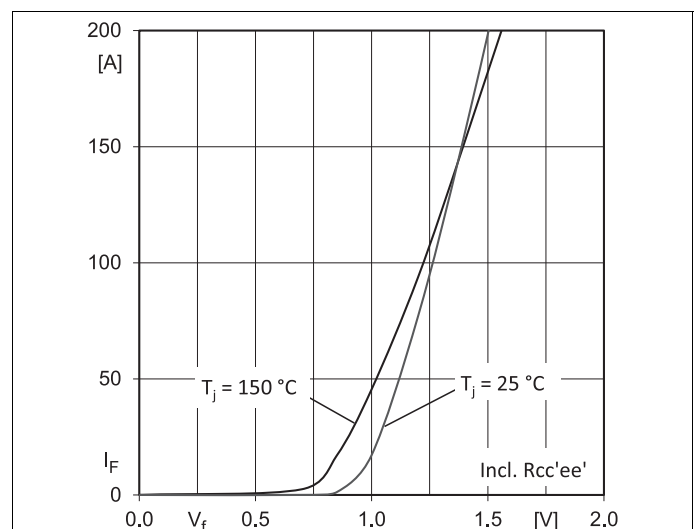

Fig. 12: Typ. input bridge forward characteristic

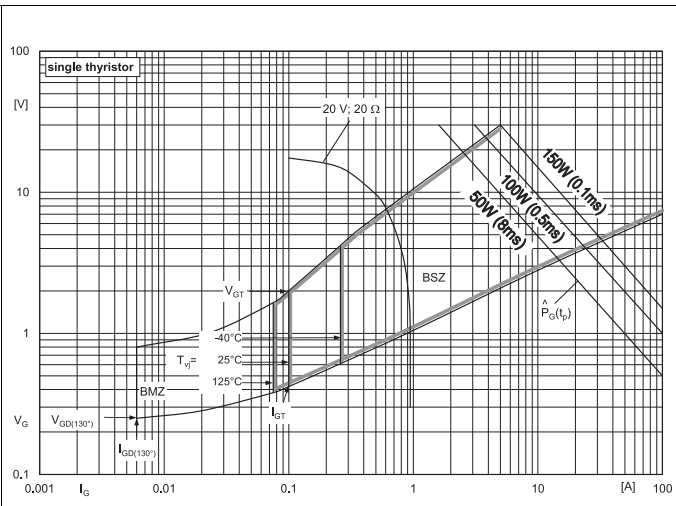
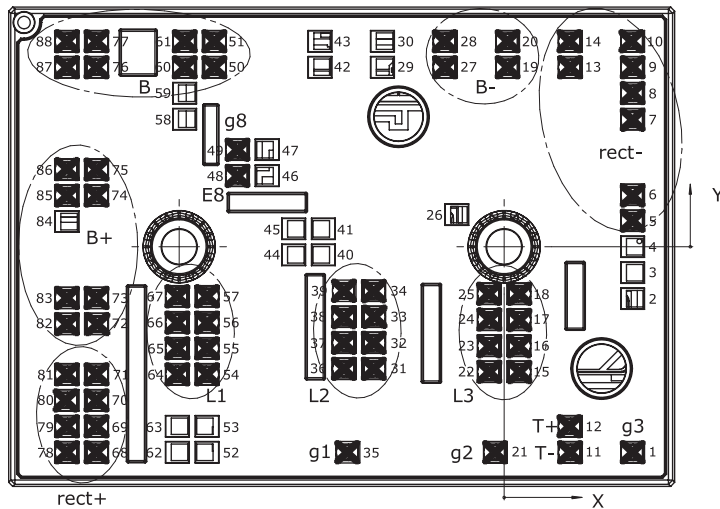

Fig. 13: Gate trigger characteristics

Pin out											
Pin	X	Y	Function	Pin	X	Y	Function	Pin	X	Y	Function
1	15,83	-25,30	g3	31	-16,05	-15,02	L2	61	-39,33	25,30	B
2	15,83	-6,40		32	-16,05	-11,82	L2	62	-40,23	-25,30	
3	15,83	-3,20		33	-16,05	-8,62	L2	63	-40,23	-22,10	
4	15,83	0		34	-16,05	-5,42	L2	64	-40,23	-15,70	L1
5	15,83	3,20	rect-	35	-19,23	-25,30	g1	65	-40,23	-12,50	L1
6	15,83	6,40	rect-	36	-19,70	-15,02	L2	66	-40,23	-9,30	L1
7	15,83	15,70	rect-	37	-19,70	-11,82	L2	67	-40,23	-6,10	L1
8	15,83	18,90	rect-	38	-19,70	-8,62	L2	68	-50,18	-25,30	rect+
9	15,83	22,10	rect-	39	-19,70	-5,42	L2	69	-50,18	-22,10	rect+
10	15,83	25,30	rect-	40	-22,26	-1,00		70	-50,18	-18,90	rect+
11	8,13	-25,30	T-	41	-22,26	2,20		71	-50,18	-15,70	rect+
12	8,13	-22,10	T+	42	-22,68	22,10		72	-50,18	-9,50	B+
13	8,13	22,10	rect-	43	-22,68	25,30		73	-50,18	-6,30	B+
14	8,13	25,30	rect-	44	-25,91	-1,00		74	-50,18	6,30	B+
15	1,83	-15,39	L3	45	-25,91	2,20		75	-50,18	9,50	B+
16	1,83	-12,19	L3	46	-29,18	8,74		76	-50,18	22,10	B
17	1,83	-8,99	L3	47	-29,18	11,94		77	-50,18	25,30	B
18	1,83	-5,79	L3	48	-32,83	8,74	E8	78	-53,83	-25,30	rect+
19	0,43	22,10	B-	49	-32,83	11,94	g8	79	-53,83	-22,10	rect+
20	0,43	25,30	B-	50	-35,68	22,10	B	80	-53,83	-18,90	rect+
21	-1,08	-25,30	g2	51	-35,68	25,30	B	81	-53,83	-15,70	rect+
22	-1,83	-15,39	L3	52	-36,58	-25,30		82	-53,83	-9,50	B+
23	-1,83	-12,19	L3	53	-36,58	-22,10		83	-53,83	-6,30	B+
24	-1,83	-8,99	L3	54	-36,58	-15,70	L1	84	-53,83	3,10	
25	-1,83	-5,79	L3	55	-36,58	-12,50	L1	85	-53,83	6,30	B+
26	-5,83	3,95		56	-36,58	-9,30	L1	86	-53,83	9,50	B+
27	-7,28	22,10	B-	57	-36,58	-6,10	L1	87	-53,83	22,10	B
28	-7,28	25,30	B-	58	-39,33	15,70		88	-53,83	25,30	B
29	-14,98	22,10		59	-39,33	18,90					
30	-14,98	25,30		60	-39,33	22,10	B				

all values in mm



Pinout and Dimensions

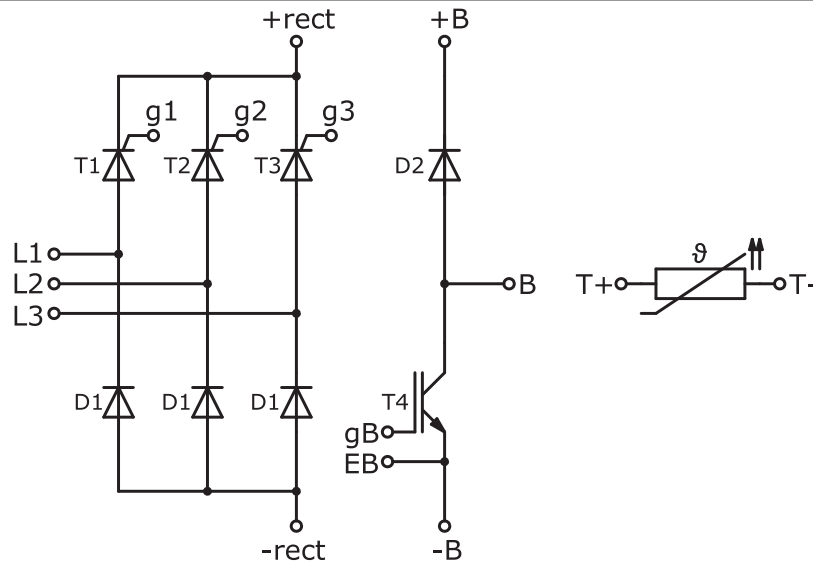

Pinout

This is an electrostatic discharge sensitive device (ESDS) due to international standard IEC 61340.

*IMPORTANT INFORMATION AND WARNINGS

The specifications of SEMIKRON products may not be considered as guarantee or assurance of product characteristics ("Beschaffheitsgarantie"). The specifications of SEMIKRON products describe only the usual characteristics of products to be expected in typical applications, which may still vary depending on the specific application. Therefore, products must be tested for the respective application in advance. Application adjustments may be necessary. The user of SEMIKRON products is responsible for the safety of their applications embedding SEMIKRON products and must take adequate safety measures to prevent the applications from causing a physical injury, fire or other problem if any of SEMIKRON products become faulty. The user is responsible to make sure that the application design is compliant with all applicable laws, regulations, norms and standards. Except as otherwise explicitly approved by SEMIKRON in a written document signed by authorized representatives of SEMIKRON, SEMIKRON products may not be used in any applications where a failure of the product or any consequences of the use thereof can reasonably be expected to result in personal injury. No representation or warranty is given and no liability is assumed with respect to the accuracy, completeness and/or use of any information herein, including without limitation, warranties of non-infringement of intellectual property rights of any third party. SEMIKRON does not assume any liability arising out of the applications or use of any product; neither does it convey any license under its patent rights, copyrights, trade secrets or other intellectual property rights, nor the rights of others. SEMIKRON makes no representation or warranty of non-infringement or alleged non-infringement of intellectual property rights of any third party which may arise from applications. Due to technical requirements our products may contain dangerous substances. For information on the types in question please contact the nearest SEMIKRON sales office. This document supersedes and replaces all information previously supplied and may be superseded by updates. SEMIKRON reserves the right to make changes.