

SK 120 GB 12F4 T



SEMITOP® 3

IGBT module

SK 120 GB 12F4 T

Features*

- Compact design
- One screw mounting module
- Optimum heat transfer and isolation through AIN direct copper bonding (DBC)
- Trench4 Fast IGBT technology
- CAL4F diode technology
- Integrated NTC temperature sensor
- UL recognized, file no. E 63 532

Typical Applications

- Switching (not for linear use)
- Inverter
- Switched mode power supplies
- UPS

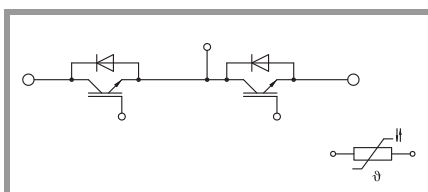

GB-T

Absolute Maximum Ratings			
Symbol	Conditions	Values	Unit
Inverter - IGBT			
V_{CES}	$T_j = 25\text{ °C}$	1200	V
I_C	$T_j = 175\text{ °C}$	$T_s = 25\text{ °C}$	174
		$T_s = 70\text{ °C}$	143
I_{Cnom}		120	A
I_{CRM}		240	A
V_{GES}		-20 ... 20	V
t_{psc}	$V_{CC} = 800\text{ V}$	$T_j = 150\text{ °C}$	10
	$V_{GE} \leq 15\text{ V}$		
	$V_{CES} \leq 1200\text{ V}$		μs
T_j		-40 ... 175	°C
Inverse - Diode			
V_{RRM}	$T_j = 25\text{ °C}$	1200	V
I_F	$T_j = 175\text{ °C}$	$T_s = 25\text{ °C}$	29
		$T_s = 70\text{ °C}$	24
I_{FRM}		30	A
I_{FSM}	10 ms, sin 180°, $T_j = 150\text{ °C}$	65	A
T_j		-40 ... 175	°C
Module			
$I_{t(RMS)}$	$\Delta T_{terminal}$ at PCB joint = 30 K, per pin	60	A
T_{stg}	module without TIM	-40 ... 125	°C
V_{isol}	AC, sinusoidal, t = 1 min	2500	V

Characteristics					
Symbol	Conditions	min.	typ.	max.	Unit
Inverter - IGBT					
$V_{CE(sat)}$	$I_C = 120\text{ A}$ $V_{GE} = 15\text{ V}$ chipelevel	$T_j = 25\text{ °C}$	2.05	2.40	V
		$T_j = 150\text{ °C}$	2.59	2.85	V
V_{CE0}	chipelevel	$T_j = 25\text{ °C}$	0.80	0.90	V
		$T_j = 150\text{ °C}$	0.70	0.80	V
r_{CE}	$V_{GE} = 15\text{ V}$ chipelevel	$T_j = 25\text{ °C}$	10	13	mΩ
		$T_j = 150\text{ °C}$	16	17	mΩ
$V_{GE(th)}$	$V_{GE} = V_{CE}, I_C = 4.5\text{ mA}$	5.2	5.8	6.4	V
I_{CES}	$V_{GE} = 0\text{ V}, V_{CE} = 1200\text{ V}, T_j = 25\text{ °C}$			1.6	mA
C_{ies}	$V_{CE} = 25\text{ V}$ $V_{GE} = 0\text{ V}$	$f = 1\text{ MHz}$	6.90		nF
C_{oes}		$f = 1\text{ MHz}$	0.56		nF
C_{res}		$f = 1\text{ MHz}$	0.41		nF
Q_G	$V_{GE} = -15\text{ V} \dots +15\text{ V}$		412		nC
R_{Gint}	$T_j = 25\text{ °C}$		2.7		Ω
$t_{d(on)}$	$V_{CC} = 600\text{ V}$	$T_j = 150\text{ °C}$	156		ns
t_r	$I_C = 120\text{ A}$	$T_j = 150\text{ °C}$	51		ns
E_{on}	$R_{G on} = 2.2\text{ }\Omega$ $R_{G off} = 2.2\text{ }\Omega$	$T_j = 150\text{ °C}$	8.8		mJ
$t_{d(off)}$	$di/dt_{on} = 2354\text{ A}/\mu\text{s}$	$T_j = 150\text{ °C}$	346		ns
t_f	$di/dt_{off} = 2264\text{ A}/\mu\text{s}$	$T_j = 150\text{ °C}$	42		ns
E_{off}	$V_{GE} = +15/-15\text{ V}$	$T_j = 150\text{ °C}$	7.47		mJ
$R_{th(j-s)}$	per IGBT, $\lambda_{paste} = 0.8\text{ W}/(\text{mK})$		0.22		K/W

SK 120 GB 12F4 T



SEMITOP® 3

IGBT module

SK 120 GB 12F4 T

Features*

- Compact design
- One screw mounting module
- Optimum heat transfer and isolation through AlN direct copper bonding (DBC)
- Trench4 Fast IGBT technology
- CAL4F diode technology
- Integrated NTC temperature sensor
- UL recognized, file no. E 63 532

Typical Applications

- Switching (not for linear use)
- Inverter
- Switched mode power supplies
- UPS

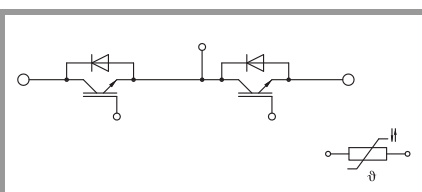

GB-T

Characteristics						
Symbol	Conditions		min.	typ.	max.	Unit
Inverse - Diode						
$V_F = V_{EC}$	$I_F = 15 \text{ A}$	$T_j = 25 \text{ °C}$		2.38	2.71	V
	chipelevel	$T_j = 150 \text{ °C}$		2.44	2.77	V
V_{F0}	chipelevel	$T_j = 25 \text{ °C}$		1.30	1.50	V
		$T_j = 150 \text{ °C}$		0.90	1.10	V
r_F	chipelevel	$T_j = 25 \text{ °C}$		72	81	mΩ
		$T_j = 150 \text{ °C}$		103	111	mΩ
I_{RRM}	$I_F = 120 \text{ A}$	$T_j = 150 \text{ °C}$		43.4		A
Q_{rr}	$di/dt_{off} = 2350 \text{ A/}\mu\text{s}$	$T_j = 150 \text{ °C}$		5.7		μC
E_{rr}	$V_{GE} = -15 \text{ V}$ $V_{CC} = 600 \text{ V}$	$T_j = 150 \text{ °C}$		2.04		mJ
$R_{th(j-s)}$	per diode, $\lambda_{paste}=0.8 \text{ W/(mK)}$			1.25		K/W
Module						
L_{CE}				-		nH
M_s	to heatsink		2.25		2.5	Nm
w				29		g
Temperature Sensor						
R_{100}	$T_c=100\text{°C}$ ($R_{25}=5 \text{ k}\Omega$)			$493 \pm 5\%$		Ω
$B_{100/125}$	$R(T)=R_{100}\exp[B_{100/125}(1/T-1/T_{100})]$; $T[\text{K}]$;			3550 $\pm 2\%$		K

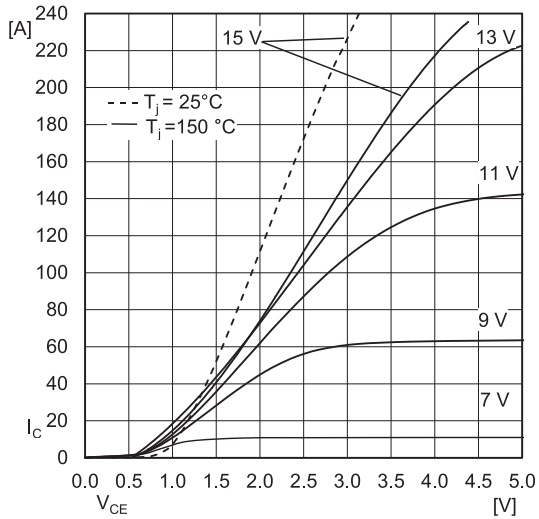

Fig. 1: Typ. output characteristic, inclusive $R_{CC'+EE'}$

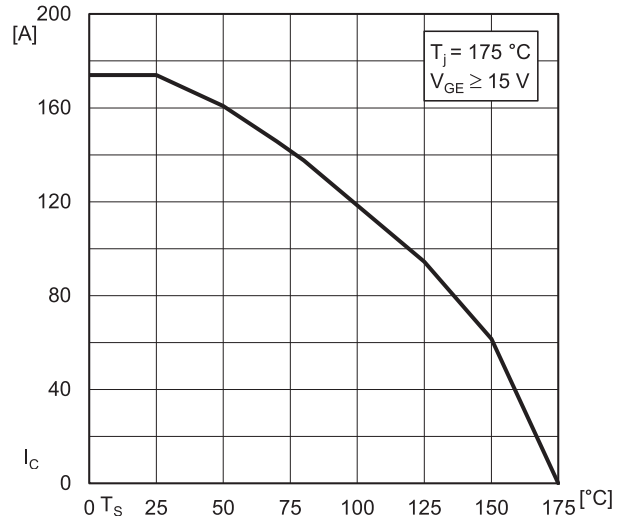

Fig. 2: Typ. rated current vs. temperature $I_C = f(T_s)$

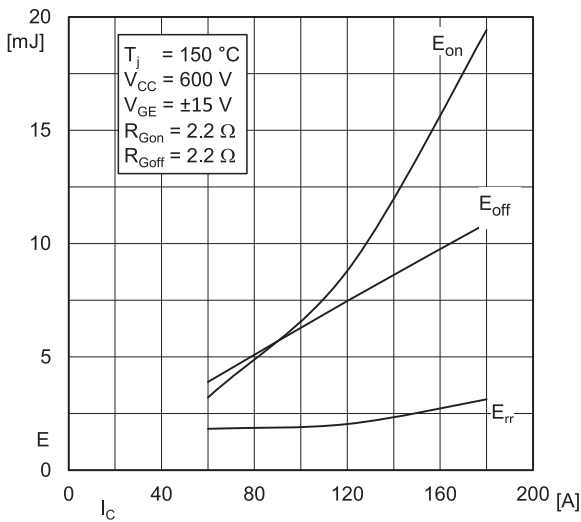

Fig. 3: Typ. turn-on /-off energy = $f(I_C)$

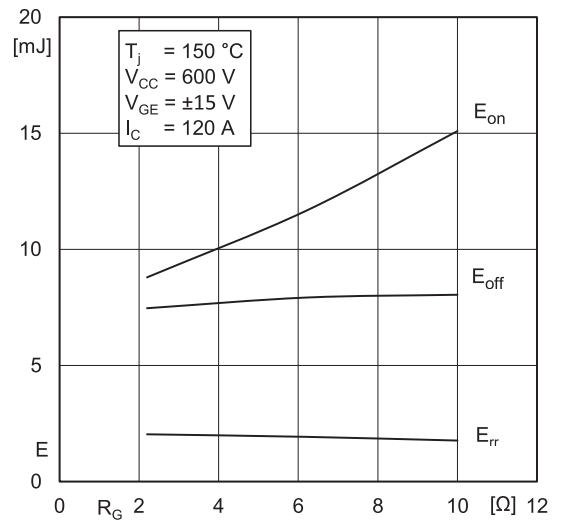

Fig. 4: Typ. turn-on /-off energy = $f(R_G)$

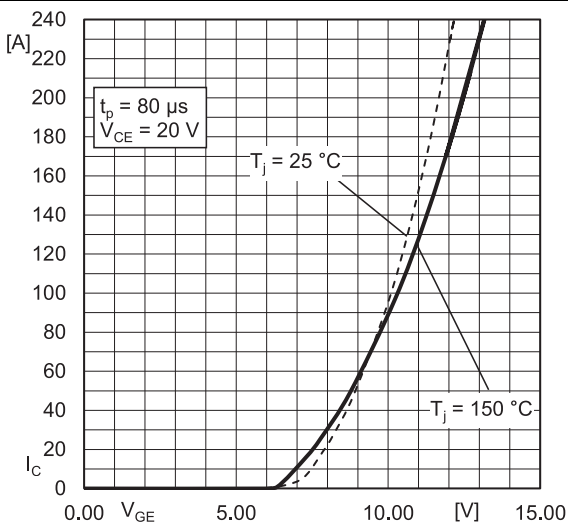

Fig. 5: Typ. transfer characteristic

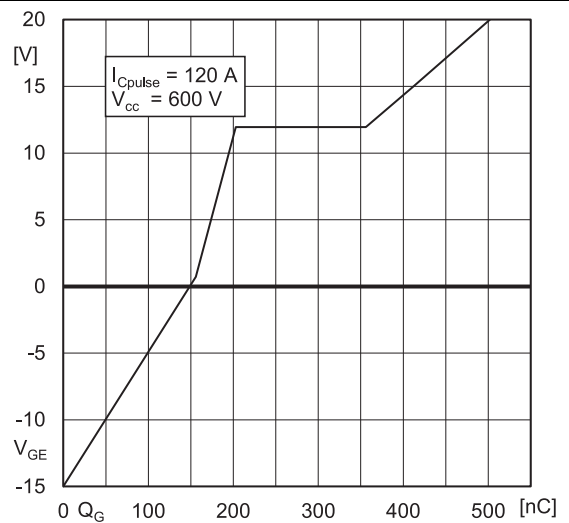

Fig. 6: Typ. gate charge characteristic

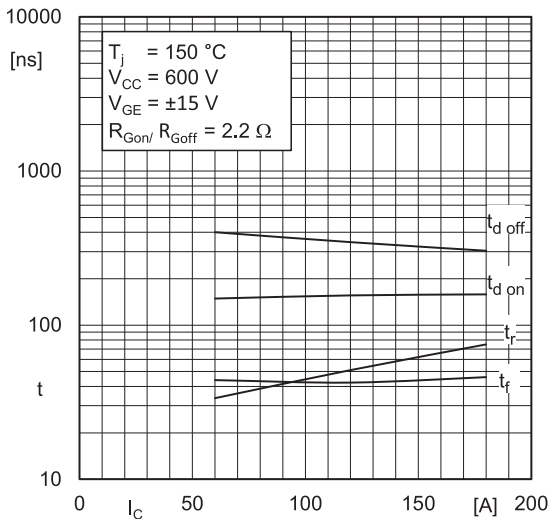

Fig. 7: Typ. switching times vs. I_C

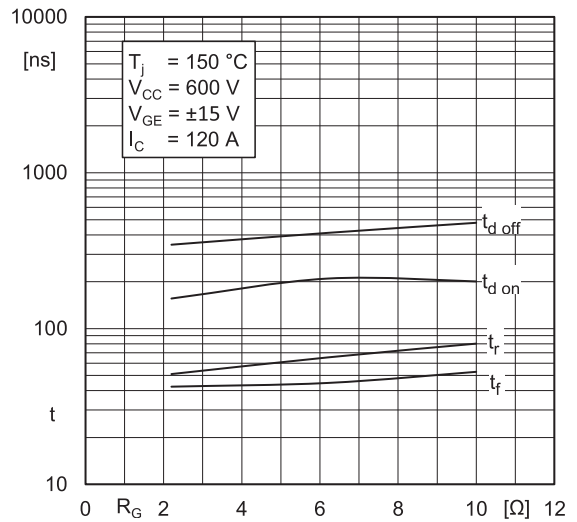

Fig. 8: Typ. switching times vs. gate resistor R_G

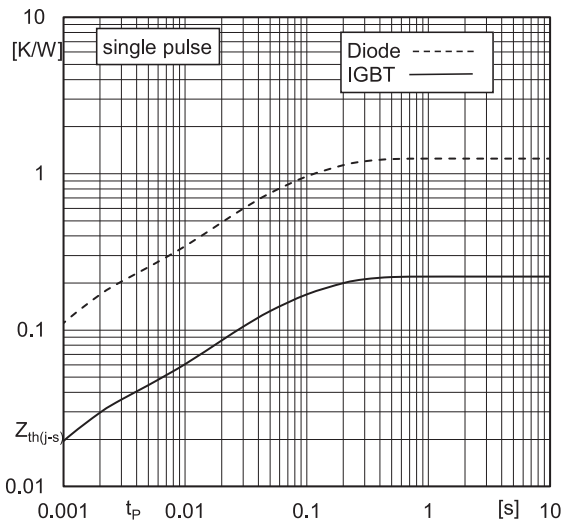

Fig. 9: Typ. transient thermal impedance

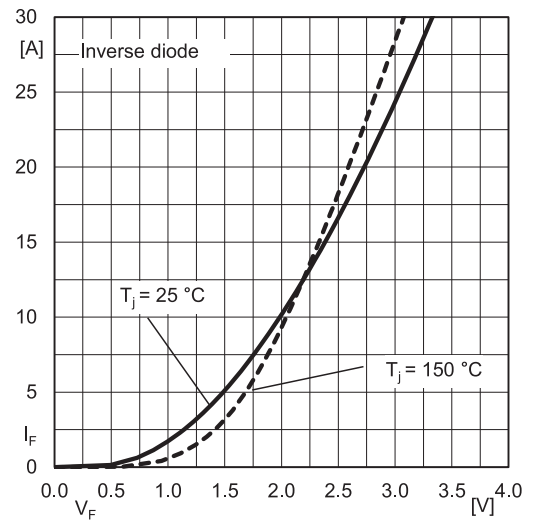

Fig. 10: Typ. CAL diode forward charact., incl. R_{CC+EE}

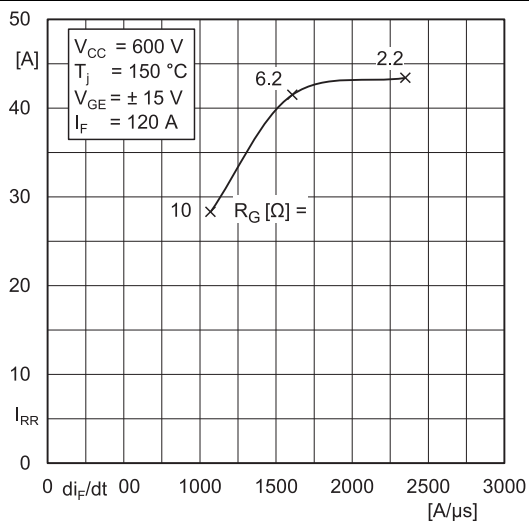
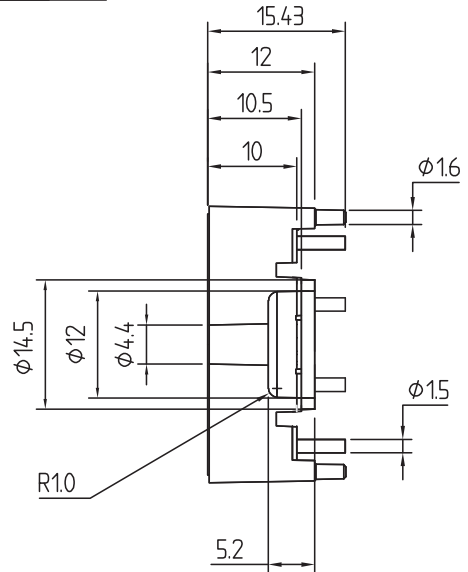
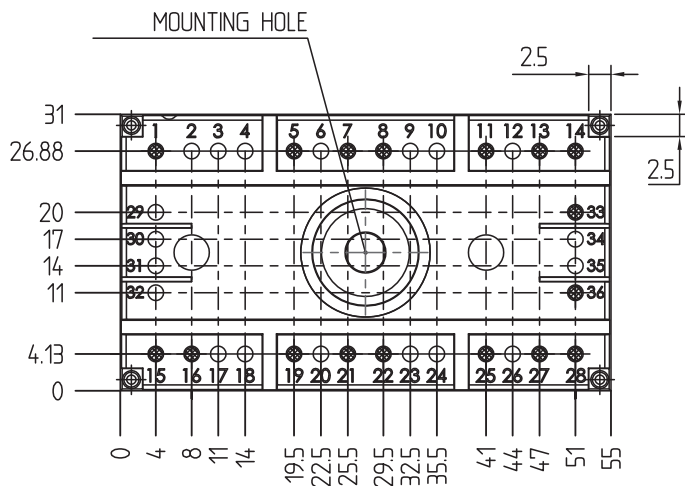
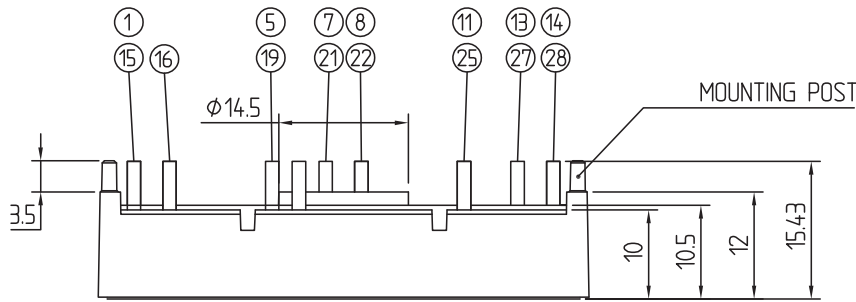

Fig. 11: Typ. CAL diode peak reverse recovery current

SK 120 GB 12F4 T

Dimensions: mm

Tolerance system: ISO 2768-m



-Hole specification for contacts:
refer Mounting Instruction SEMITOP® Classic

suggested hole diameter for the mounting post in the circuit board:

- refer Mounting Instruction SEMITOP® Classic

These documents are SEMIKRON properties. SEMIKRON reserves all copyrights. All copying and transmitting of this information requires written permission. For the case of industrial property rights, SEMIKRON reserves all rights.

SEMITOP®3

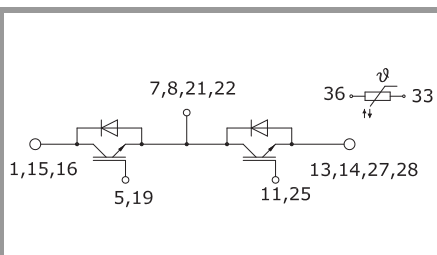

GB-T

This is an electrostatic discharge sensitive device (ESDS) due to international standard IEC 61340.

***IMPORTANT INFORMATION AND WARNINGS**

The specifications of SEMIKRON products may not be considered as guarantee or assurance of product characteristics ("Beschaffenheitsgarantie"). The specifications of SEMIKRON products describe only the usual characteristics of products to be expected in typical applications, which may still vary depending on the specific application. Therefore, products must be tested for the respective application in advance. Application adjustments may be necessary. The user of SEMIKRON products is responsible for the safety of their applications embedding SEMIKRON products and must take adequate safety measures to prevent the applications from causing a physical injury, fire or other problem if any of SEMIKRON products become faulty. The user is responsible to make sure that the application design is compliant with all applicable laws, regulations, norms and standards. Except as otherwise explicitly approved by SEMIKRON in a written document signed by authorized representatives of SEMIKRON, SEMIKRON products may not be used in any applications where a failure of the product or any consequences of the use thereof can reasonably be expected to result in personal injury. No representation or warranty is given and no liability is assumed with respect to the accuracy, completeness and/or use of any information herein, including without limitation, warranties of non-infringement of intellectual property rights of any third party. SEMIKRON does not assume any liability arising out of the applications or use of any product; neither does it convey any license under its patent rights, copyrights, trade secrets or other intellectual property rights, nor the rights of others. SEMIKRON makes no representation or warranty of non-infringement or alleged non-infringement of intellectual property rights of any third party which may arise from applications. Due to technical requirements our products may contain dangerous substances. For information on the types in question please contact the nearest SEMIKRON sales office. This document supersedes and replaces all information previously supplied and may be superseded by updates. SEMIKRON reserves the right to make changes.